



Model 101 & 2100

(Including Pass-Thru Door Models 103, 105,
107, 2125, 2127, 2130)

Service & Installation



November, 2012

99-13312-S001

Contents:

1. Models 101 & 2100 Door & Frame – Reversible Parts Placement (Start 10/89)	6
2. Models 101 & 2100 Reversible Door Parts Placement (1989 to 1991)	7
3. Models 101 & 2100 Standard (Before 7/94) Frame Net Opening Widths.....	8
3.1.1. 24" Door (Catalog Size) 23-3/16" Actual Door Width	8
3.1.2. 26" Door (Catalog Size) 26-3/8" Actual Door Width	8
3.1.3. 30" Door (Catalog Size) 29-7/8" Actual Door Width	8
4. Models 101 & 2100 Standard Frame Net Opening Heights	9
5. Models 101 & 2100 Frame Installation	9
6. Frame Divider Board Installation (Prior to 1993)	10
7. Reversible/Cordless Door & Hold-Open Installation.....	11
8. Reversing Frame Hardware	12
9. Door Reversing Instructions Models 101 & 2100 (1989-1991).....	13
10. Door Reversing Instructions (1991 to Present)	16
11. Models 103, 105, 107, 2125, 2127 & 2130 Pass-Thru Installation	17
12. Frame Sill Plastic protector Installation Models 101 & 2100.....	19
13. Contact Plate and Contact Plate Retainer Replacement.....	20
14. Ordering Replacement Doors.....	21
15. Torquemaster Replacement.....	22
16. Door Gasket Replacement	22
17. Door Plastic (Cover) Replacement.....	23
18. Door Cut-Away & Handle Replacement	23
19. Side Access Plate Replacement (1989 to 1991)	24
20. Side Access Plate Replacement (1991 to Present).....	24
21. Door Female Plug Replacement (1989 to 1991)	25
22. Frame Female Plug and/or Socket Replacement (1991 to Present).....	25
23. Door Heater Replacement (1989 to 1991) Model 101 Only	26
24. Door Heater Replacement (1991 to Present) Model 101 Only.....	26
25. Hinge Pin Replacement (1989 to 1991)	27
26. Hinge Pin Replacement (1991 to Present).....	27

27. Wiring Instructions, Heated & Non-Heated Glass (1991 to Present).....27

28. Torque Rod Replacement (1987 to 1991)28

29. Torque Rod Replacement (1991 to Present).....28

30. Front Bumper Bar Field Installation28

31. Model 101 Door Cylinder Lock Replacement or Repair29

32. P.O.M. Lock Installation30

33. P.O.M. Lock Installation31

34. Model 101 Glass Replacement (Reglazing)32

35. Ordering Replacement Frames35

36. Frame Heater Wire Replacement.....36

37. Models 101 & 2100 Frame Heater Schematic/Low Temp37

38. Models 101 & 2100 Frame Heater Schematic/Normal Temp37

39. Humastat Installation Procedure38

40. Model 101 Humastat40

41. Model 101 & 2100 Shelf Assembly Catalog Size/Shelf Size40

42. Models 101 & 2100 Frame & Shelving with Standard Lighting.....42

43. Models 101 & 2100 Frame & Shelving with “ELS” Electronic Lighting43

44. Four-Post Stabilizer Bar Installation44

45. Four-Post Shelf System Installation44

46. Plastic Tag Molding Installation.....46

47. Model 2100 G.F.I. Location & Wiring Diagram47

48. Lamp Replacement47

49. Lamp Socket Replacement48

50. Recessed Light Socket Replacement.....49

51. Recessed Lamp Channel Replacement with Remote Ballast49

52. Recessed Lamp Guard Replacement with Remote Ballast.....50

53. Recessed Lamp Replacement50

54. “Boost & Buck” Transformer Wiring Diagram50

55. Frame Junction Box Wiring (Standard Production)51

56. Models 101 & 2100 Light Fixture Placement (Prior to 10/93)51

Model 101/2100 Doors Service & Installation

57. Models 101 & 2100 Light Fixture Placement – “Continuous” Lineup (10/93 to Present)	52
58. Models 101 & 2100 Low Temp 120-Volt Remote Ballast and Lamp Wiring Diagram for 1-Light Systems	53
59. Models 101 & 2100 Low Temp 120-Volt Remote Ballast and Lamp Wiring Diagram for 2-Light Systems	54
60. Models 101 & 2100 Normal Temp 120-Volt Remote Ballast and Lamp Wiring Diagram for 1- & 2-Light Systems.....	55
61. Models 101 & 2100 Normal Temp 120-Volt Remote Ballast and Lamp Wiring Diagram for 3-Light Systems	55
62. Normal Temp & Low Temp 120-Volt Ballast and Lamp Wiring Diagram - Pre-Wired 1-Light System	56
63. Ballast Replacement	56
64. “ELS” Lamp Socket Replacement.....	57
65. “ELS” Electronic Ballast Replacement and Wiring Instructions	59
66. T-8 Lamp Replacement Instructions.....	65
67. Dew Point Chart	71
68. Electrical Information for Model 101 Low Temp Heated Doors, Frames & Standard Light Fixtures Heater Amperages @ 120 Volts.....	72
69. Electrical Information for Model 101 Normal Temp Heated Doors, Frames & Standard Light Fixtures Heater Amperages @ 120 Volts	73
70. Heat Load in BTU/Hr for Model 101 Low Temp Glass, Door Rail, Frame Heaters and Standard Lighting (Per Door, with Doors Closed @ 75°F Store Ambient).....	76
71. Heat Load in BTU/Hr for Model 101 Normal Temp Glass, Door Rail, Frame Heaters and Standard Lighting (Per Door, with Doors Closed @ 75°F Store Ambient).....	76
72. Heat Load in BTU/Hr for Model 2100 Low Temp Glass, Door Rail, Frame Heaters and Standard Lighting (Per Door, with Doors Closed @ 75°F Store Ambient).....	78
73. Electrical Information for Model 2100 Low Temp Heated Doors, Frames & Standard Light Fixtures Heater Amperages @ 120 Volts	79
74. Electrical Information for Model 2100 Normal Temp Doors, Frames & Standard Light Fixtures Heater Amperages @ 120 Volts.....	80
75. Heat Load in BTU/Hr for Model 2100 Normal Temp Glass, Door Rail, Frame Heaters and Standard Lights (Per Door, with Doors Closed @ 75°F Store Ambient).....	81
76. Heat Load in BTU/Hr for Model 101 Low Temp Glass, Door Rail, Frame Heaters and “ELS” Electronic Lighting System (Per Door, with Doors Closed @ 75°F Store Ambient) ..	82

77. Electrical Information for Model 101 Low Temp Doors, Frames & “ELS Electronic Lighting System Heater Amperages @ 120 Volts83

78. Electrical Information for Model 101 Normal Temp Doors, Frames & “ELS” Electronic Lighting System Heater Amperages @ 120 Volts84

79. Heat Load in BTU/Hr for Model 101 Normal Temp Glass, Door Rail, Frame Heaters and “ELS” Electronic Lighting System (Per Door, with Doors Closed @ 75°F Store Ambient) ..87

80. Electrical Information for Model 2100 Low Temp Doors, Frames & “ELS” Electronic Lighting System Heater Amperages @ 120 Volts88

81. Heat Load in BTU/Hr for Model 2100 Normal Temp Glass, Door Rail, Frame Heaters and “ELS” Electronic Lighting System (Per Door, with Doors Closed @ 75°F Store Ambient).....89

82. Heat Load in BTU/Hr for Model 2100 Low Temp Glass, Door Rail, Frame Heaters and “ELS” Electronic Lighting System (Per Door, with Doors Closed @ 75°F Store Ambient) ..90

83. Electrical Information for Model 2100 Normal Temp Doors, Frames & “ELS” Electronic Lighting System Heater Amperages @ 120 Volts90

84. Troubleshooting92

85. Safety Precautions94

86. Tips94

1. Models 101 & 2100 Door & Frame – Reversible Parts Placement (Start 10/89)

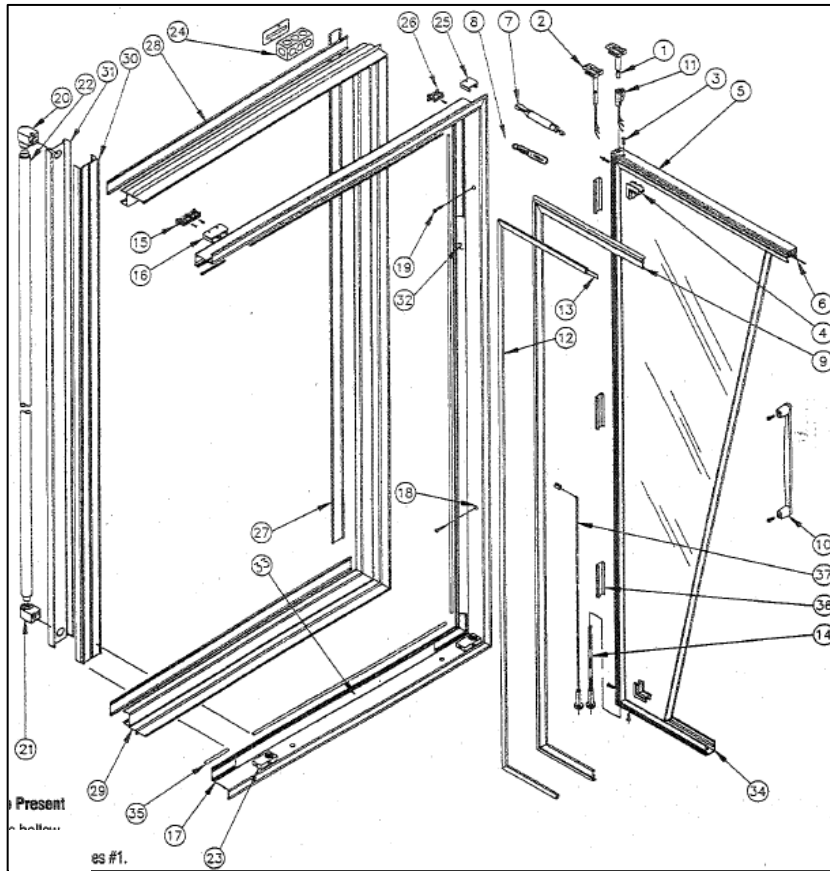

Change: Present

- 1. Hinge Rail is hollow.
- 2. Use #2 Hinge Pin; replaces #1.
- 3. Delete #11 Receptacle.
- 4. Single hinge side Access Hole in center of Hinge Rail only. Delete #36.

Description	Description	Description	Description
1. Hinge Pin	11. Female Receptacle	21. Bottom Lamp Socket	31. Light Fixture
2. Molded Hinge Pin ('91)	12. Magnetic Gasket	22. Bulb	32. Contact Plate
3. Corner Screw	13. Magnet	23. Torquemaster	33. Contact Plate
4. Corner Piece	14. Torque Rod	24. Junction Box	34. Door Extrusion
5. Door Extrusion	15. Double Socket	25. Single Receptacle	35. Retainer
6. Heater Wire	16. Double Receptacle	26. Single Socket	36. Access Hole Cover Plate
7. Hold-Open ('86-90)	17. Frame Extrusion	27. Raceway Cover	
8. Hold-Open ('90)	18. Installation Hole	28. Raceway Cover	37. Torque Rod (Right Angle)
9. Door Cover	19. Installation Screw	29. Raceway	
10. Door Handle	20. Top Lamp Socket	30. Frame Mullion	

2. Models 101 & 2100 Reversible Door Parts Placement (1989 to 1991)

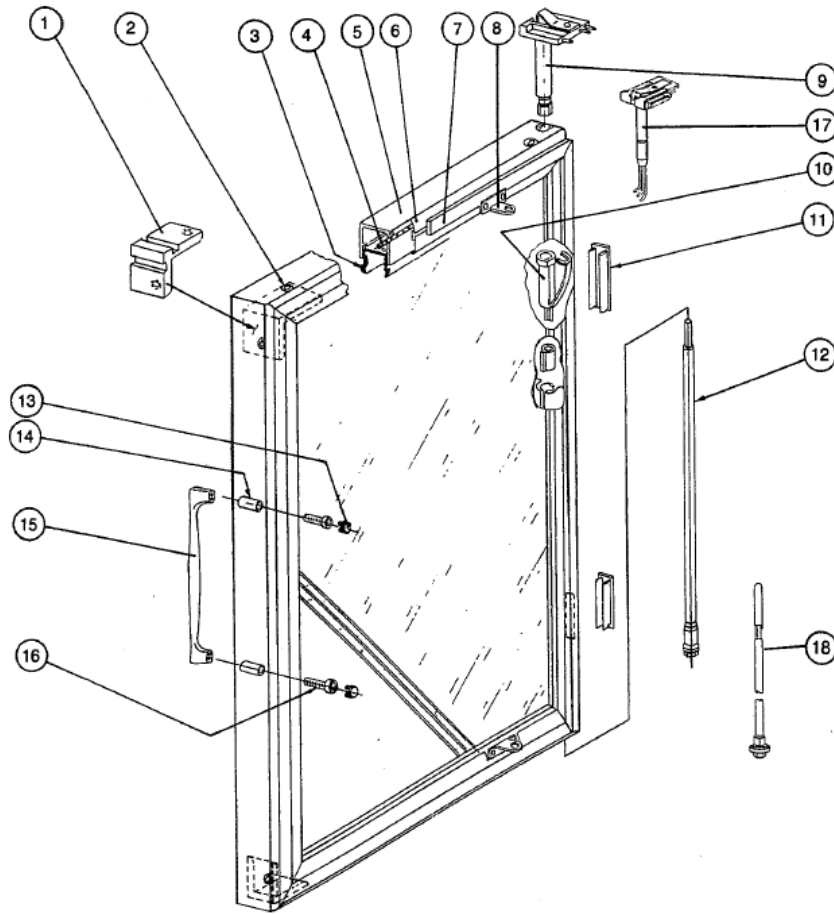

Changes: 1991 to Present

1. Hinge Rail is hollow.
2. Use #17 Hinge Pin; replaces #9.
3. Delete #10 Receptacle.
4. Use #18 Torque Rod; replaces #12
5. Single hinge side Access Hole in center of Hinge Rail only. Delete #11.

Description	Description	Description
1. Corner Piece	7. Gasket	13. Cap
2. Corner Screw	8. Camel Back	14. Access Tube
3. Glazing Channel	9. Hinge Pin	15. Handle
4. Heater Wire	10. Receptacle	16. Handle Screw
5. Door Rail	11. Cover	17. Molded Hinge Pin
6. Plastic	12. Torque Rod	18. Torque Rod

3. Models 101 & 2100 Standard (Before 7/94) Frame Net Opening Widths

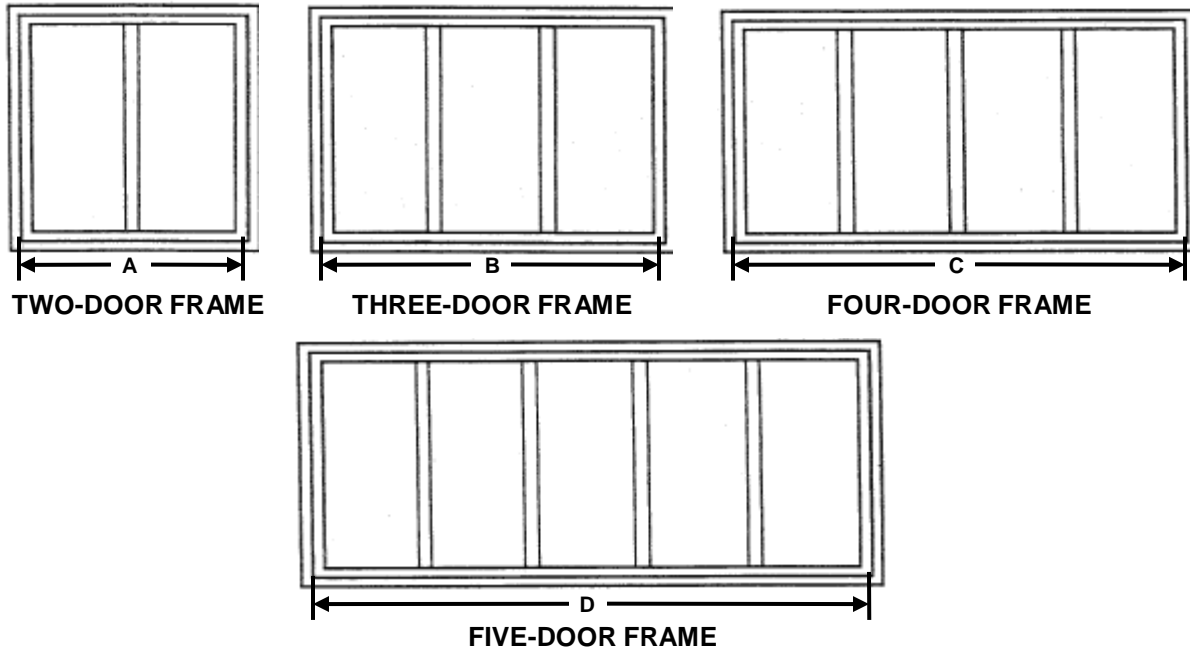

3.1. Frame Width Data

3.1.1. 24" Door (Catalog Size) 23-3/16" Actual Door Width

		A	B	C	D
ENDLESS MULLION	FINISHED FRAME NET OPENING	48-5/8"	72-3/8"	96-1/8"	119-7/8"
FULL FLANGE	FINISHED FRAME NET OPENING	48-7/8"	72-5/8"	96-3/8"	120-1/8"

3.1.2. 26" Door (Catalog Size) 26-3/8" Actual Door Width

		A	B	C	D
ENDLESS MULLION	FINISHED FRAME NET OPENING	55-1/4"	82-3/16"	109-1/8"	136-1/16"
FULL FLANGE	FINISHED FRAME NET OPENING	55-1/2"	82-7/16"	109-3/8"	136-5/16"

3.1.3. 30" Door (Catalog Size) 29-7/8" Actual Door Width

		A	B	C	D
ENDLESS MULLION	FINISHED FRAME NET OPENING	62"	92-7/16"	122-7/8"	153-5/16"
FULL FLANGE	FINISHED FRAME NET OPENING	62-1/4"	92-11/16"	123-1/8"	153-9/16"

4. Models 101 & 2100 Standard Frame Net Opening Heights

4.1. Frame Height Data

	CATALOG DOOR HEIGHT			
	75"	73"	67"	63"
FINISHED FRAME	74-13/16"	72-13/16"	66-13/16"	64-9/16"
NET OPENING HEIGHT	75"	73"	67"	64-3/4"

4.2. Door Size

	CATALOG WIDTH			CATALOG HEIGHT			
	24"	26"	30"	75"	73"	67"	63"
ACTUAL SIZE	23-3/16"	26-3/8"	29-7/8"	73-1/16"	71-1/16"	65-1/16"	62-13/16"

5. Models 101 & 2100 Frame Installation

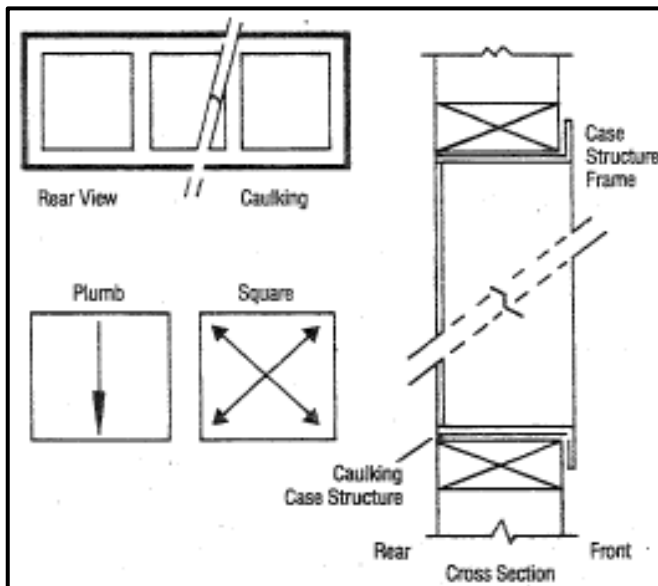

Frame Installation

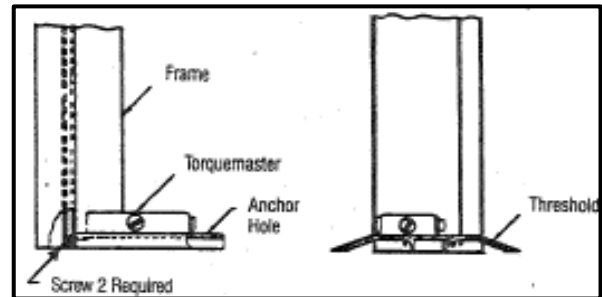

Pass-Thru Cross Section (w/wo Threshold)

1. Read instructions completely before installing frames.
2. Openings must conform to net openings listed in Price Book or other.
3. Check size of finished frame to net opening.
4. **Do not force frame into tight opening.**
5. Check net opening for plumb and square as shown. Sill must be level left to right and front to back.
 - a. Jambs, header and sill should be wood for a secure installation
 - b. Anthony door frame needs a sill of at least 1-1/2" for proper installation.

6. Set frame in net opening. For safety, partially install wood screws in top of frame. Do not tighten. Torquemaster (silver rectangular box) goes at bottom of frame; hinge pin to top of frame.
7. Check frame for square, as shown. Shim as necessary. Ensure that shims are placed as close to installation holes as possible. When shimming is necessary, shim top and bottom and/or left end of frame and right end of frame to maintain square of frame in net opening.

Continuous Lineup Frames:

8. Set next frame into case opening and snug frame against **right** side of first frame.
9. Square and plumb second frame. For safety, **partially** install wood screws in top of frame.
10. Insert sex bolts through right side of first frame, into left side of second frame. Tighten until frames are pulled together.
11. From inside of case, **caulk all four sides of frame**, between frame and opening.
12. Starting with frame sill, install mounting screws and tighten, then do sides and top. **Do not over-tighten top screws, as this will bow frame.**
13. From inside the case, re-check caulking.

6. Frame Divider Board Installation (Prior to 1993)

Instructions are for multiple full flange frame lineups.

Frames are shipped with divider board taped to end of frame.

Divider board is pre-cut to given net opening height. For example, a 75" net opening will get a 75" divider board, and a 67" net opening will get a 67" divider board.

If net opening height varies, make up the difference with a solid shim.

1. Set frame into case opening and push frame tight against left side of opening. Square and plumb frame. Install installation screws on bottom of frame, left end of frame and top of frame.
2. Insert divider board behind flange on right side of frame. Toenail divider board to sill and header, if possible. (Metal cover plate is on customer side.) Screw right end of frame to divider board.
3. Set next frame into net opening and snug frame against divider board. Install screws through left side of frame into divider board.
4. When adding divider boards and frame sections, always make sure frames are plumb and square.
5. Continue adding frames and divider boards to complete line-up.
6. **Divider boards must be snug between sill and header.**

7. Reversible/Cordless Door & Hold-Open Installation

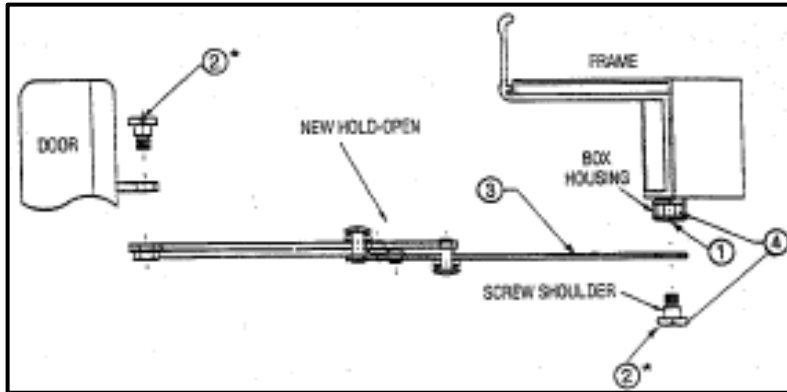

Model 101 and 2100 Hold-Open Instructions

Note: Replace spare shoulder screw (#2) in spare box housing nut (#4) when installing or reversing a door.

1. Align door with torque rod and insert into the Torquemaster socket at base of door.

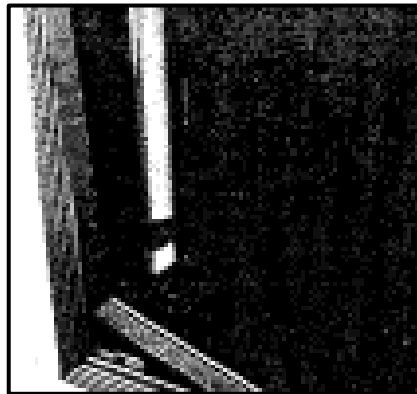

2. Engage door with hinge pin plug inserted into hinge pin plug receptacle at top of frame.



3. Push door into top frame with thumb until hinge pin plug snaps into place.

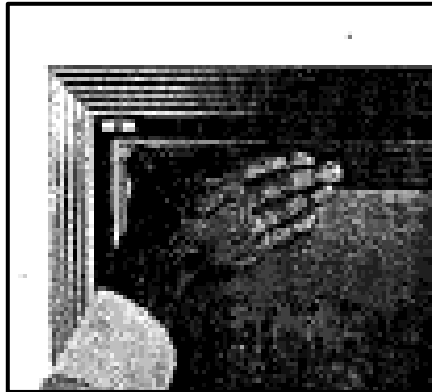

4. Adjust closing force by turning the screw on the front of the Torquemaster with a flat-head screwdriver. Turn counter-clockwise to tighten, clockwise to loosen.

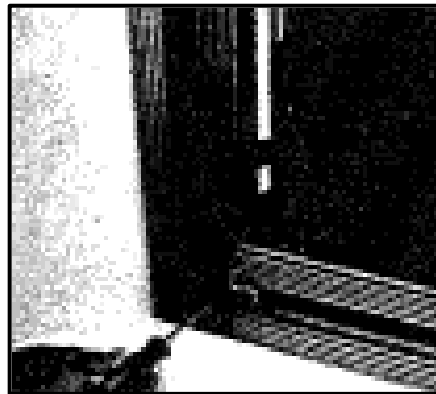

5. If necessary to square door in frame opening, turn end screw on Torquemaster (marked SAG ADJ) with a flat-head screwdriver.
6. ***Do not use power tools for installation or removal.***

8. Reversing Frame Hardware

1. Remove Torquemaster by turning center screw counter-clockwise.

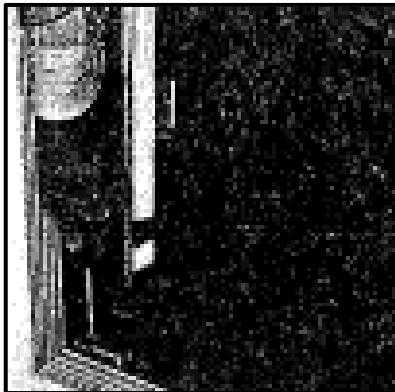

2. Remove back cover plate with flat-head screwdriver and insert into opposite Torquemaster hole. Replace and re-install Torquemaster in new position.



3. Insert back safety cover plate into opposite side hinge receptacle.

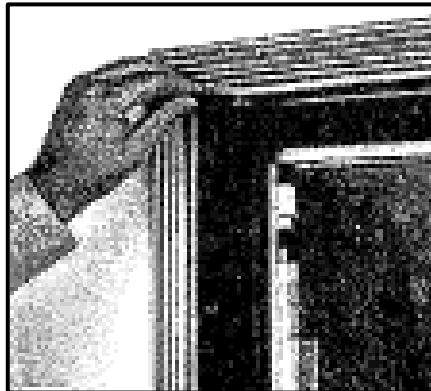

4. *Do not use power tools for installation or removal.*

9. Door Reversing Instructions Models 101 & 2100 (1989-1991)

1. Release tension on Torquemaster by turning front screw clockwise.

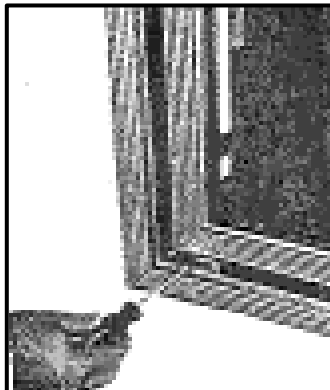

2. **On Hold-Open (1990 to Present)**, remove shoulder screw from camel back hinge on back of door (Model 101 and 2100 Hold-Open Instructions).

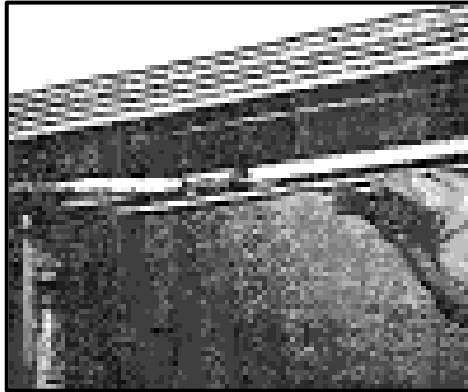

3. Remove hinge pin plug from frame by inserting needle-nose pliers into hinge pin plug 1/8" hole. Compress and pull hinge pin plug away from frame.

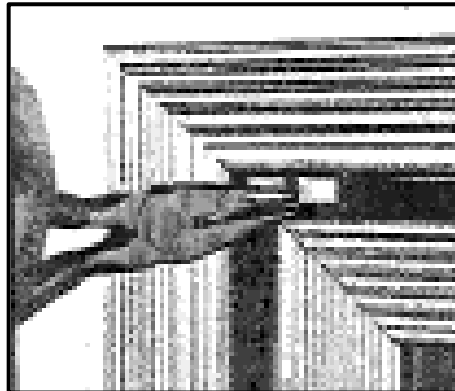

4. Lift door out of Torquemaster. Lean door on its side against a stable surface.

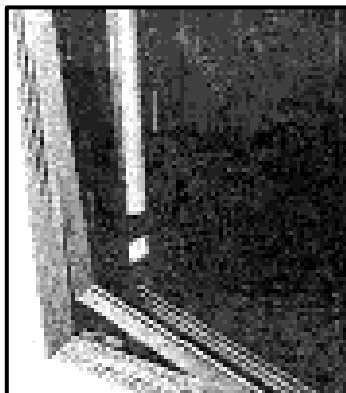

- 5. Remove hinge pin plug access cover from hinged side of door.

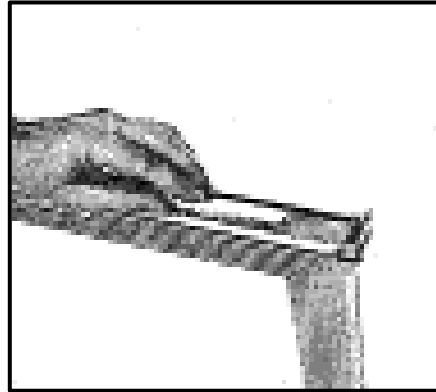

- 6. Disengage safety snap from female plug, remove male plug from door and insert in opposite end of door.

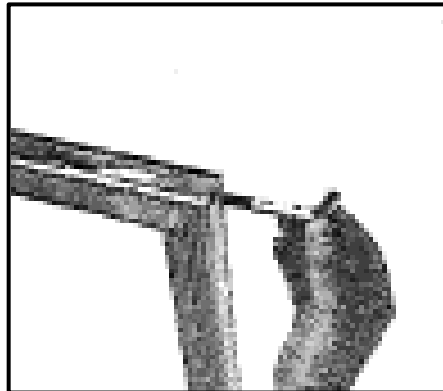

- 7. Remove torque rod by sliding it out bottom of door and insert in opposite end of door.

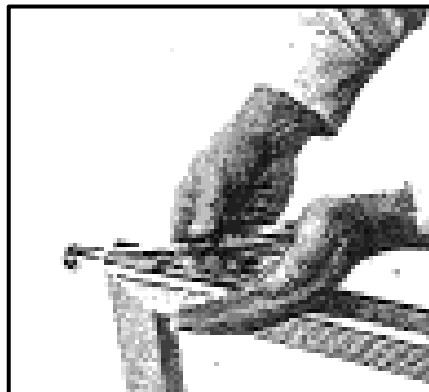

- 8. Model 101 & 2100 have only one female receptacle. When reversing door, also reverse receptacle. Pull receptacle from one end and feed back down through opposite end.

9. Carefully replace hinge pin access covers.

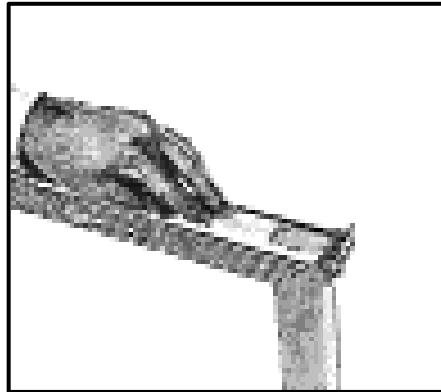

10. **Do not use power tools for installation or removal.**

11. See Model 101 & 2100 torque rod below.



10. Door Reversing Instructions (1991 to Present)

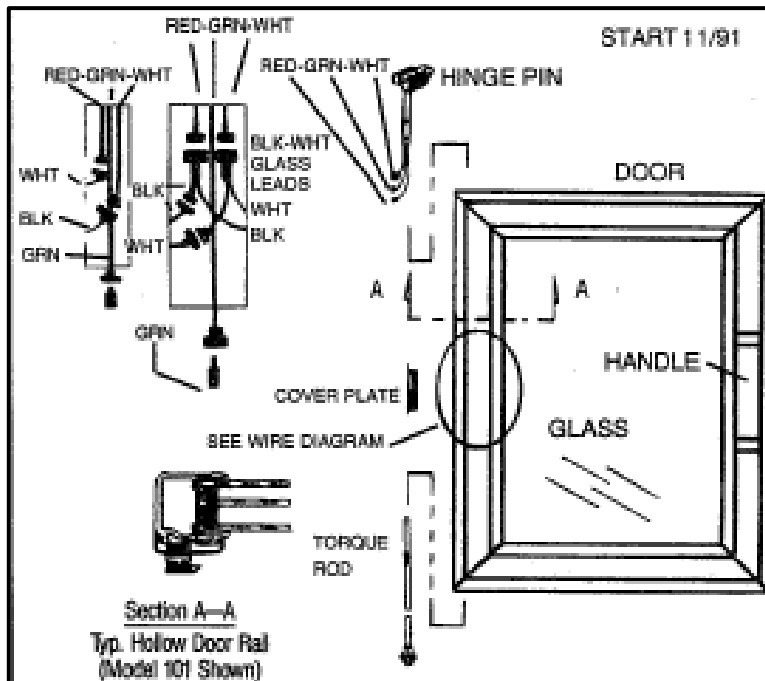

Door Quick Disconnect and Reversing

1. Reverse door hardware.
 - a. Remove cover plate from center hinge side of door.
 - b. Disconnect hinge pin connectors from door heater and/or glass heater connectors.
 - c. Pull hinge pin out through top of door.

- d. Remove torque rod from bottom of door; pull rod down and out.
 - e. Insert torque rod in opposite end of door.
 - f. Insert hinge pin in opposite end of door.
 - g. Plug in hinge pin connectors to door heaters and/or glass heaters.
2. Wiring Instructions:
- Heated Glass:**
- a. If glass is heated, unplug Black and White lead wires from glass.
 - b. To re-connect heated glass, plug in Black and White lead wires coming off heater loom to Black and White lead wires from glass.
- Non-Heated Glass:**
- a. Connect Black or Red lead wires from hinge pin to Black or Red door heater lead.
 - b. Connect White lead wire from hinge pin to White door heater lead.
3. Replace hinge side cover plate.
4. Re-install door.

11. Models 103, 105, 107, 2125, 2127 & 2130 Pass-Thru Installation

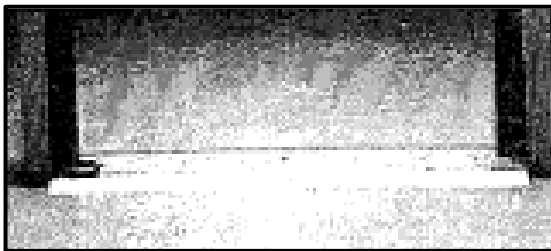

With Threshold

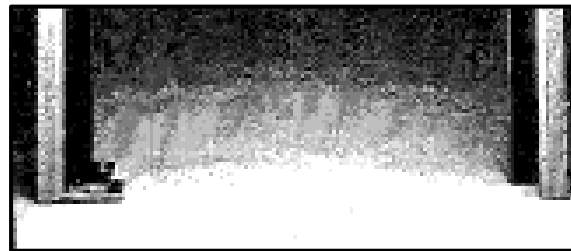

Without Threshold

Note: If a roll-a-way cart is included in order, it must be behind the door before installing frame.

- 1. Refer to Frame Installation instruction to install frame.
- 2. When threshold is desired, drill and tag on pre-drilled mounting holes only.
- 3. For installation of door and hold-open, use Reversible/Cordless Door & Hold-Open Installation instructions.
- 4. With door in closed position, adjust floor wiper seal to fit flush with door and/or slab. Turn screws clockwise to tighten and counter-clockwise to loosen.

- 5. For additional bottom support, Anthony Pass-Thrus are equipped with a base plate and two special floor anchor bolts.

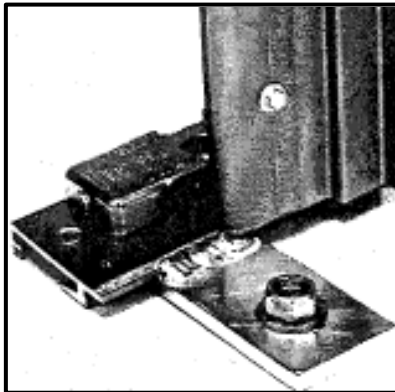

- 6. Pass-Thru Frame Wiring Diagrams
 - a. With Threshold

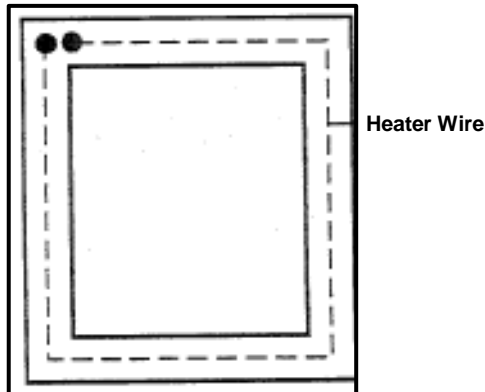

- b. Without Threshold

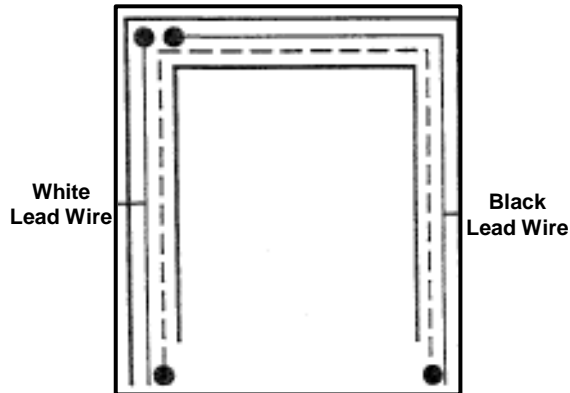

11.1. Pass-Thru 101 Model Numbers

- 1. Model 103: All glass or all solid panel.
- 2. Model 105: 1/3 glass, 2/3 solid panel.
- 3. Model 107: All glass with Roll-A-Way cart.

11.2. Pass-Thru 2100 Model Numbers

1. Model 2130: All clear glass with colored border, or all glass with solid color.
2. Model 2125: 1/3 clear glass, 2/3 solid color glass.
3. Model 2127: All clear glass with colored border, and Roll-A-Way cart.

12. Frame Sill Plastic protector Installation Models 101 & 2100

1. Set metal protector on sill inside of case between clear opening of frame, with curved edge over bottom sill plastic.
2. Stick frame guard to top of bottom raceway with two-way tape provided.

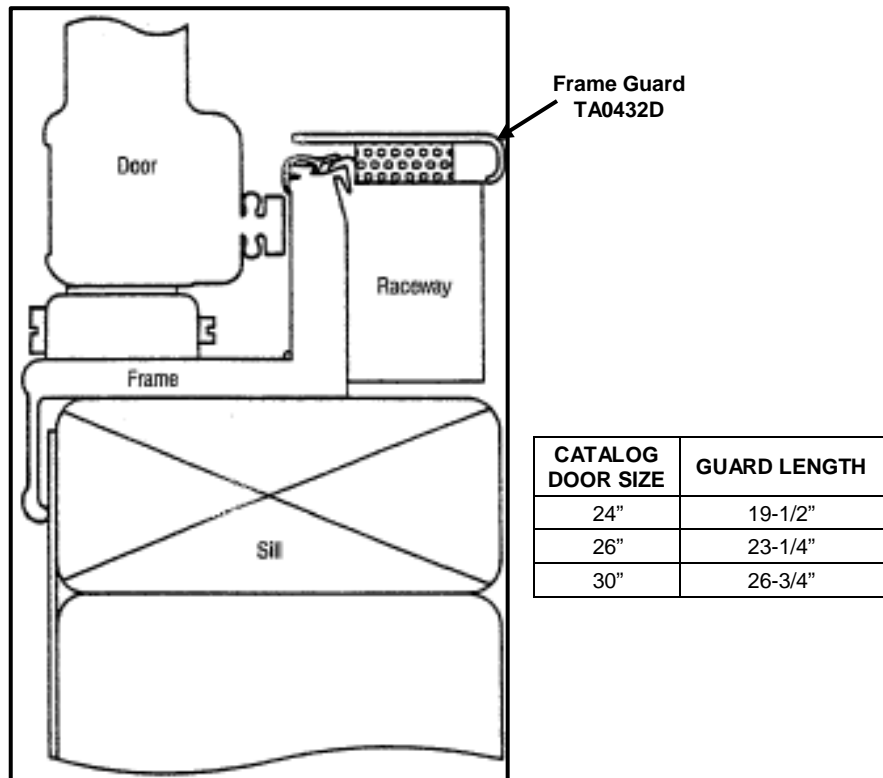

NOTE: Foam 5/16" x 3/4" Polyethelene #8302 unless otherwise specified.

13. Contact Plate and Contact Plate Retainer Replacement

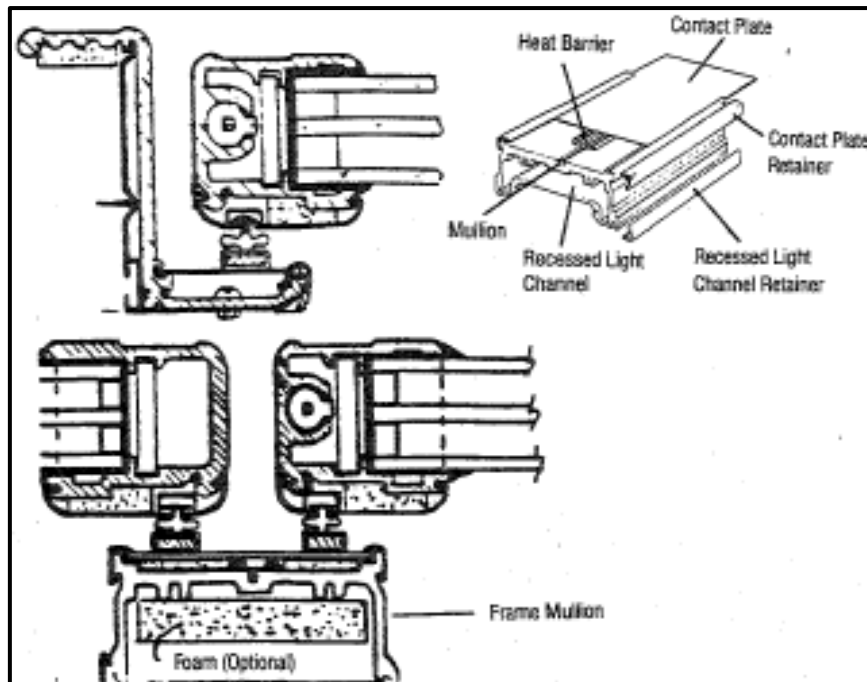

End and Center Mullion (1987 to Present)

Note: In the illustration above, Model 100R is shown. Model 100FR is the same except for the mullion and mullion contact plate. Model 101 is the same except for the mullion cover as shown in *Door Quick Disconnect and Reversing*.

1. Remove door.
2. To remove contact plate and contact plate retainer, insert flat-head screwdriver under side back edge of retainer plastic.

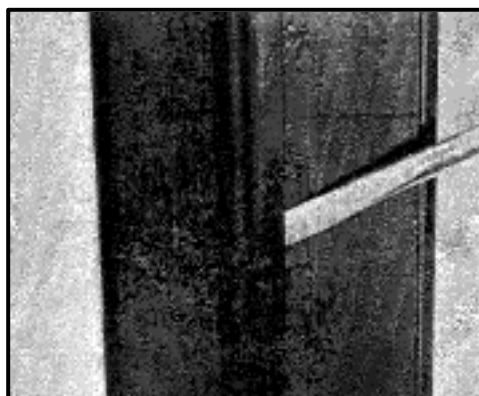

Pull up to unsnap retainer from mullion and perimeter of frame. Remove contact plate. Frame heaters are now exposed.

- 3. To replace retainer and contact plate, lay contact plate flat on frame rail, insert top front leg edge of retainer between the contact plate and the mullion. Snhap retainer on back edge of mullion and perimeter of frame.
- 4. Contact plate for prewired ballast frame is 3-7/16" wide. Contact plate for non-prewired frames is 2-1/2" wide.

14. Ordering Replacement Doors

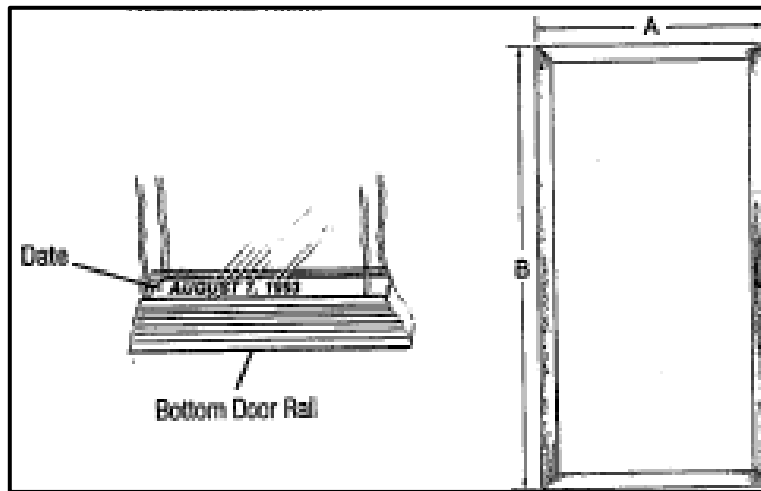

Replacement Doors (All Swing Door Models)

- 1. Specify outside dimensions of door (measure to nearest 1/16").
- 2. With or without heaters?
- 3. Hinge swing; left or right?
- 4. Specify model: Cooler or Freezer?
- 5. Specify finish.
- 6. Specify any custom items in the original order.
- 7. Specify date of original order and/or Anthony confirmation/invoice number. (Original manufacture date is stamped on metal spacer bar between panes of glass, as shown above.
- 8. With or without locks?
- 9. Specify voltage.

15. Torquemaster Replacement

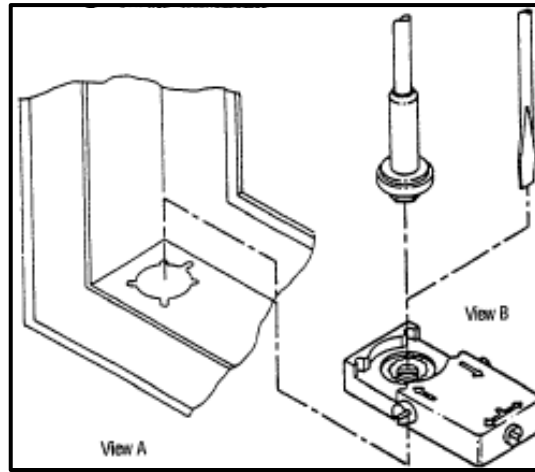

Torquemaster

1. Torquemaster is used on all standard production frames.
2. To remove, insert flat-head screwdriver into top center cutout in Torquemaster and turn screw 1/8" turn. If necessary, insert small flat-head screwdriver between edge of Torquemaster and frame and gently pry up.
3. Reverse instructions to replace.

16. Door Gasket Replacement

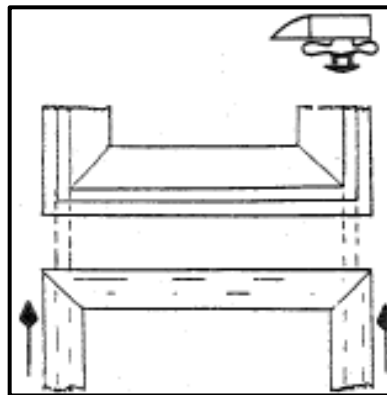

Door Gasket

1. Remove old gasket by starting in corner, gently pulling gasket away from plastic.

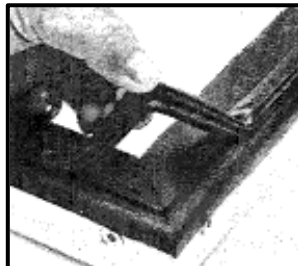

- Model 101** To replace gasket, remove top and bottom door plastic and slide the gasket up the two verticals. Slide top and bottom plastic onto gasket and replace top and bottom plastic on door rail. Tuck in corners of gasket with a flat-head screwdriver.

Model 2100 Lay new gasket over track in back of door rail. With a single-edged plastic roller, roll in the outside edge of door gasket first, then the inside edge. Tuck in all four corners.

- Reverse instructions to replace.

17. Door Plastic (Cover) Replacement

- Starting in corner, gently pull rubber gasket away from door plastic.
- With gasket removed, insert flat-head screwdriver under outside edge of plastic and gently pry up. At either end of plastic, run screwdriver the complete length and width of door rail. With outside edge of plastic released, push plastic toward glass to remove.

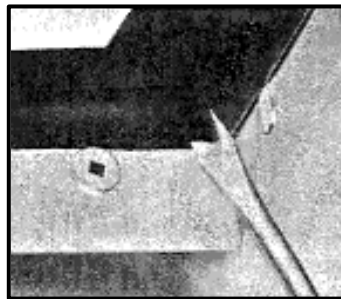

- To replace, insert inside edge of plastic into inside door rail groove. Snap outside edge of plastic over outside edge of door rail.

18. Door Cut-Away & Handle Replacement

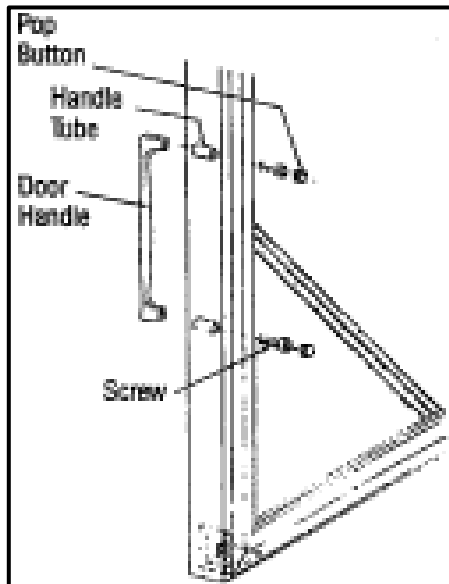

Handle Replacement

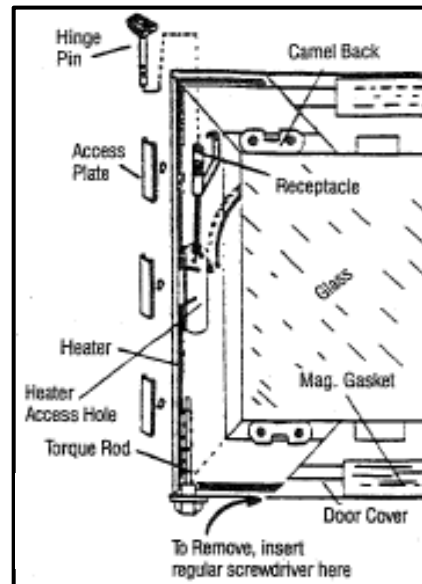

Door Cut-Away

1. **Model 101** Remove plastic hole plug from back of door plastic.
2. Insert 5/32" Allen wrench into access holes and turn screws counter-clockwise to remove.
3. Reverse instructions to replace handle.
4. **Model 2100** Remove screws on side of door rail
5. Reverse instructions to re-install.

19. Side Access Plate Replacement (1989 to 1991)

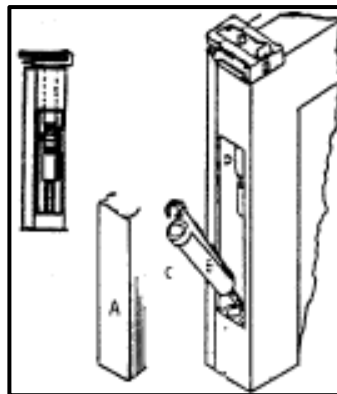

Hinge Pin and Cover Plate

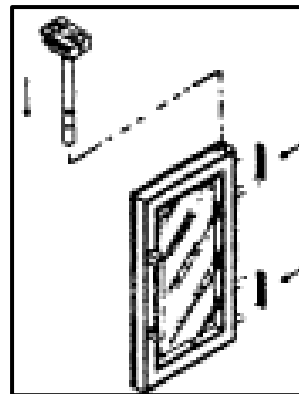

Hinge Pin Removal

Note: Lead Wires: Heater (Black, White), Receptacle (Black, White, Green), Glass (Black, White).

1. Side access plate is located at top side of door.
2. To remove, insert flat-head screwdriver under edge of cover and lift up.
3. Snap plate into door extrusion to replace.

20. Side Access Plate Replacement (1991 to Present)

1. Access plate is located on the center of the hinge rail (*Door Quick Disconnect and Reversing*).
2. To remove side access plate, insert small flat-head screwdriver under edge of cover and lift up.
3. Snap plate into door extrusion to replace.

21. Door Female Plug Replacement (1989 to 1991)

1. **Model 101 Only** – Gently insert flat-head screwdriver under edge of top side access plate and pull up to remove (*Hinge Pin and Cover Plate/Door Cut-Away*).
2. Unsnap hinge pin from female receptacle.
3. Female plug is installed with additional lead wire. Pull female plug out through access hole and cut Black, White and Green/Yellow lead wires.
4. Reverse instructions to replace door female plug. Re-wire Black to Black, White to White and Green/Yellow to ground.
5. Replace side access plate.

22. Frame Female Plug and/or Socket Replacement (1991 to Present)

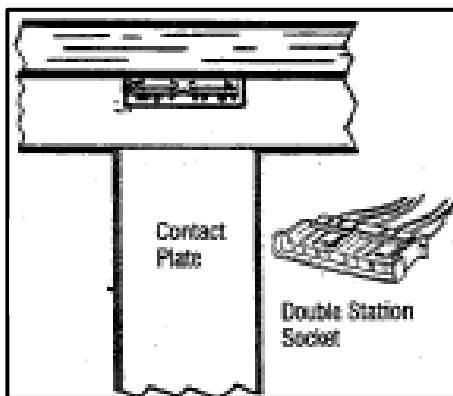

Double Station Socket
Model 100R, 100FR, 101 (1989)

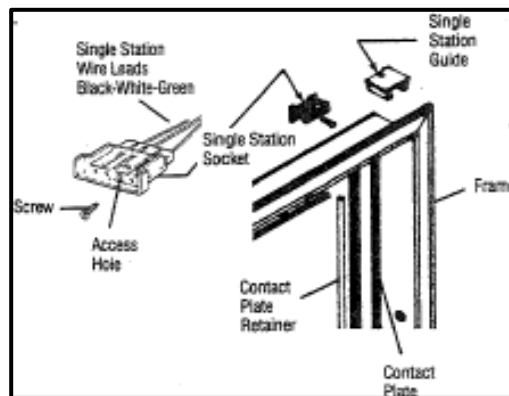

Single Station Socket
Model 100R, 100FR, 101 (1987 to Present)

Note: Double Station Socket Wire Leads – 2 Reds, 2 Whites, 2 Greens

1. **Model 101 Only** – Frame female plug is removed through front side of frame.
2. Insert small Phillips-head screwdriver into round access hole in face of female plug, and turn screw counter-clockwise to remove. **For double station socket replacement**, remove two screws out through front.
3. Female plug has extra length wire leads in raceway for easy placement.
4. Pull plug out front and cut lead wires: Black-White, and Green/Yellow.
5. Reverse instructions to re-wire: Black to Black, White to White and Green/Yellow to ground.

23. Door Heater Replacement (1989 to 1991) Model 101 Only

1. Remove door gasket and plastic.

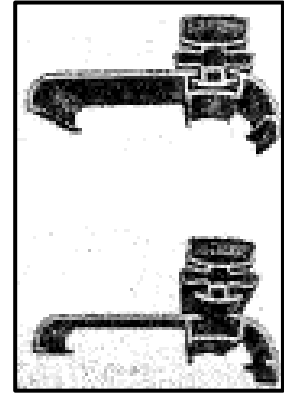
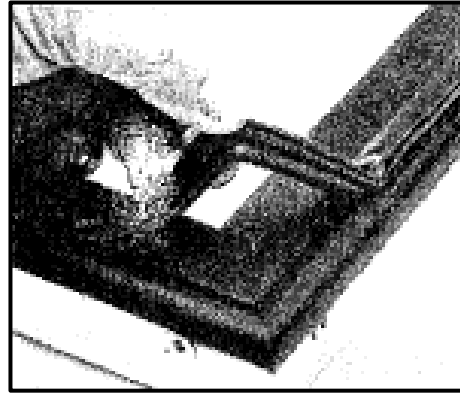
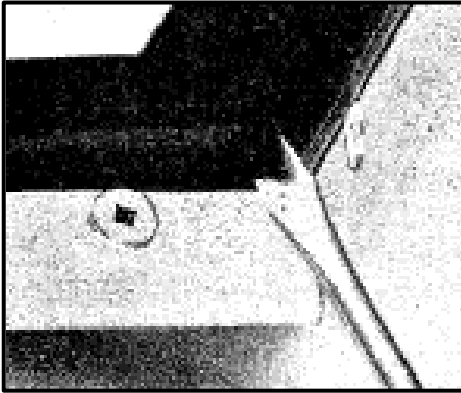

2. Remove side access plate (*Door Cut-Away*).
3. Unsnap hinge pin from female receptacle.
4. Wiring for the door is done in the center side of hinge rail.
5. To remove heater, cut solid lead wires: Black, White and Green/Yellow (ground).

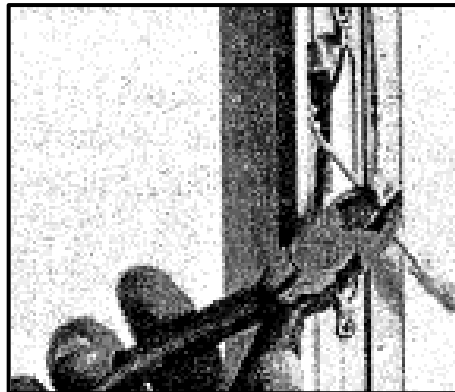

6. Heater wire lies in track on the back outside edge of door. Pull heater out.
7. If glass is heated, cut Black and White lead wires from glass.
8. Reverse instructions to replace door heater. Wire Black to Black, White to White and Green/Yellow to ground. If heated glass is used, reconnect glass Black and White lead wires to heater Black and White lead wires.

24. Door Heater Replacement (1991 to Present) Model 101 Only

1. Remove door plastic and door gasket.
2. Remove center side access plate (*Door Quick Disconnect and Reversing*).
3. To remove heater, unplug solid lead wires: Black or Red, White and Yellow/Green (ground).

4. If glass is heated, unplug Black and White solid wires from glass.
5. Heater wire lies in track on the back outside edge of door. Pull heater out.
6. Reverse instructions to replace door heater. Plug in Black or Red lead wire from hinge pin to Black or Red lead wire from heater, White lead wire from hinge pin to White heater lead and Green/Yellow lead from hinge pin to ground.
Note: If glass is heated, plug in Black and White lead wires coming off heater loom to Black and White lead wires from glass.

7. Replace side access plate.
8. Replace door plastic and gasket.

25. Hinge Pin Replacement (1989 to 1991)

1. **Model 101** - Remove top side access plate (*Door Cut-Away*).
Note: Lead Wires: Heater (Black, White), Receptacle (Black, White, Green), Glass (Black, White).
2. Unsnap female receptacle from hinge pin and remove hinge pin out through top door rail.
3. Reverse instructions to replace.

26. Hinge Pin Replacement (1991 to Present)

1. **Model 101 & 2100** - Remove center hinge side access plate (*Door Quick Disconnect and Reversing*).
2. Unplug Black or Red lead wire from hinge pin from Black solid heater wire lead.
3. Unplug White lead wire from hinge pin from White solid heater wire lead.
4. Unplug Green/Yellow (ground) lead wire.
5. If glass is heated, unplug Black and White lead wire on heater loom from Black and White lead wire from glass.
6. Pull hinge pin out through top of door.
7. Reverse instructions to replace.

27. Wiring Instructions, Heated & Non-Heated Glass (1991 to Present)

1. **Heated Glass** – Connect Black or Red lead wire from hinge pin to Black lead wire from glass and Red or Black lead wire from door heater (*Door Quick Disconnect and Reversing*).
2. Connect White heater lead wire from hinge pin to glass White lead wire.
3. **Non-Heated Glass** – Connect Black or Red lead wire from hinge pin to Black or Red door heater lead.
4. Connect White lead wire from hinge pin to White door heater lead.

- 5. Replace hinge side cover plate.
- 6. Re-install door.

28. Torque Rod Replacement (1987 to 1991)

- 1. To remove torque rod, use flat-head screwdriver. Catch edge of torque rod shaft and tap rod down and out through bottom of door.

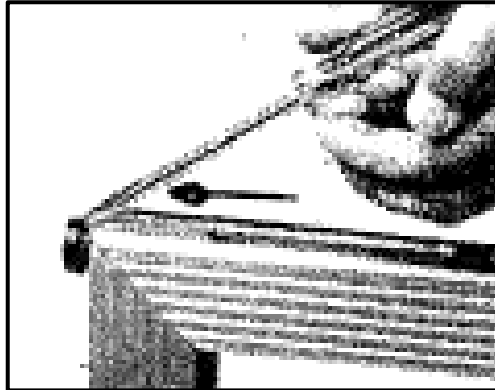

- 2. Reverse instructions to replace.

29. Torque Rod Replacement (1991 to Present)

- 1. To remove torque rod, use flat-head screwdriver. Catch edge of torque rod shaft with screwdriver and tap rod down into place (*Door Quick Disconnect and Reversing*).
- 2. To replace, slide end of rod up hinge rail, then insert square shaft of torque rod into square hole in door rail. Tap into place.

Note: Torque rod has no tip.

30. Front Bumper Bar Field Installation

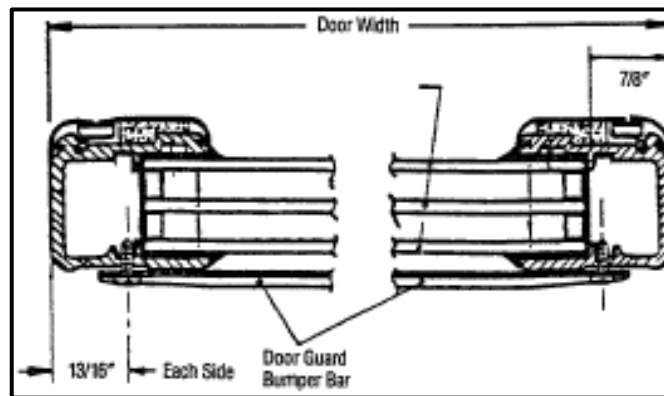

Front Bumper Bar

- 1. Order door guards 1" smaller than actual door width.
- 2. Specify finish (Gold/Silver).

3. Anthony provides pre-drilled screw holes in bar. Customer must drill a #30 or 1/8" hole in door rail 13/16" from each side of door rail.
4. Screws for mounting bar are self-tapping. **Screws are not to exceed 3/8" in length.**
5. Mount bar at desired vertical height to protect door glass.

31. Model 101 Door Cylinder Lock Replacement or Repair

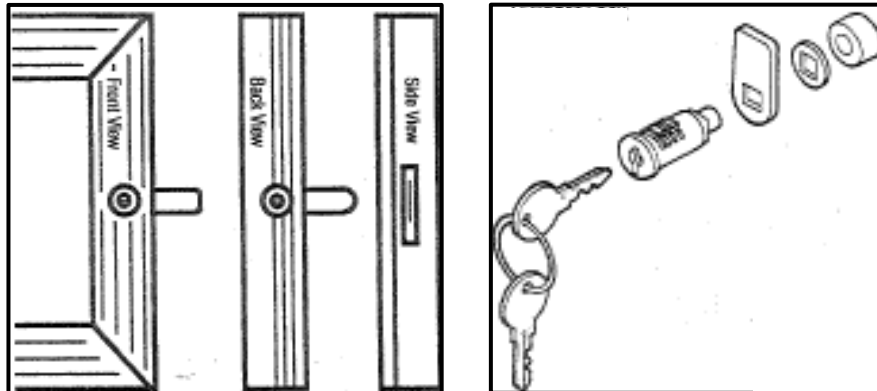

Cylinder Lock

1. If lock arm is bent or damaged, remove door plastic from back of door.

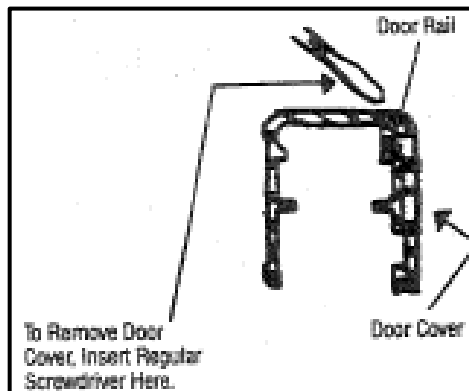

2. Insert Allen wrench in lock access hole and remove screw.
3. Pull washers out, then lock arm and replace.
4. Reverse instructions to replace.
5. If cylinder lock is defective, follow instruction #2 above. Insert key into lock and pull lock out through front of door.
6. Reverse instructions to replace.

32. P.O.M. Lock Installation

1. Remove dummy plug from hinge pin access plate on top of frame on handle side of door.

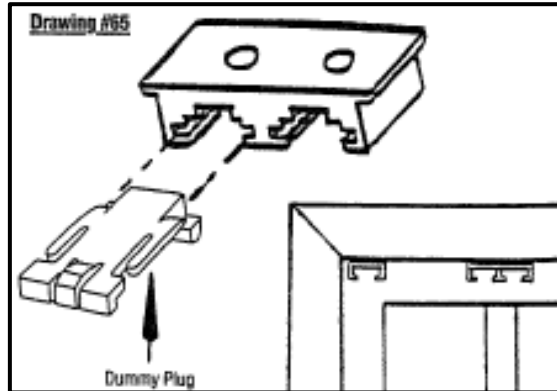

2. The P.O.M Lock inserts into a hinge pin access plate.

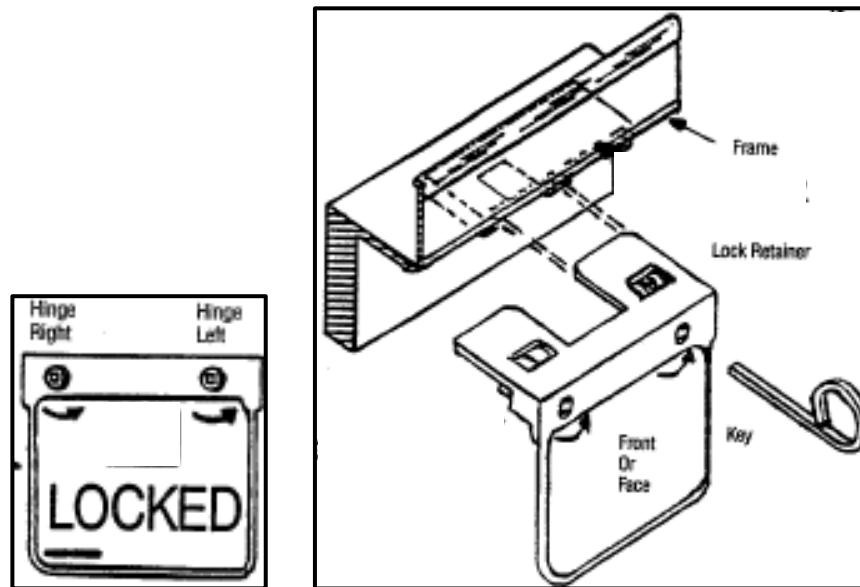

3. Insert key into P.O.M Lock's square keyhole and turn key counterclockwise to lock.
4. Remove key.
5. To remove P.O.M. Lock, insert key into square hole and turn key clockwise.
6. Pull straight out to remove lock.
7. Replace dummy plug.
8. Lock only side that inserts into hinge access plate.
9. Facing doors, the lock on the right side is for left-hinged doors and the lock on the left side is for right-hinged doors.

- 10. The P.O.M. Lock is manufactured to install in frame on top of handle rail side of door.
- 11. For retrofitting the P.O.M. Lock on existing doors in the field, contact Anthony Customer Service or the local Sales Representative for information and instructions.

33. P.O.M. Lock Installation

- 1. To install the retrofit retainer, measure in 1-1/2" from the edge of door (handle side) and mark frame above the door.

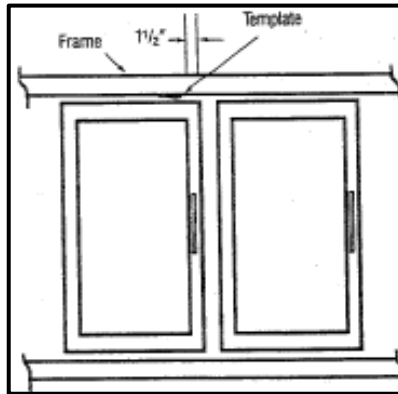

- 2. Place template provided on frame, with the right edge of the template on the mark previously made on the frame.

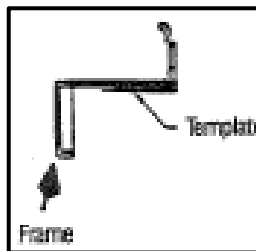

- 3. Mark the frame through the five (5) holes on the template with a pencil. Remove template and center punch the marks on the frame.
- 4. Drill the four (4) outboard holes with an 11/64" drill, the center hole with a 5/8" drill and deburr holes.
- 5. Place retrofit retainer bracket over the holes with the rectangular notch out. Use #10-32 x 5/16" screws provided and mount retainer bracket to frame.

6. Insert P.O.M. Lock into access plate and turn key to lock.

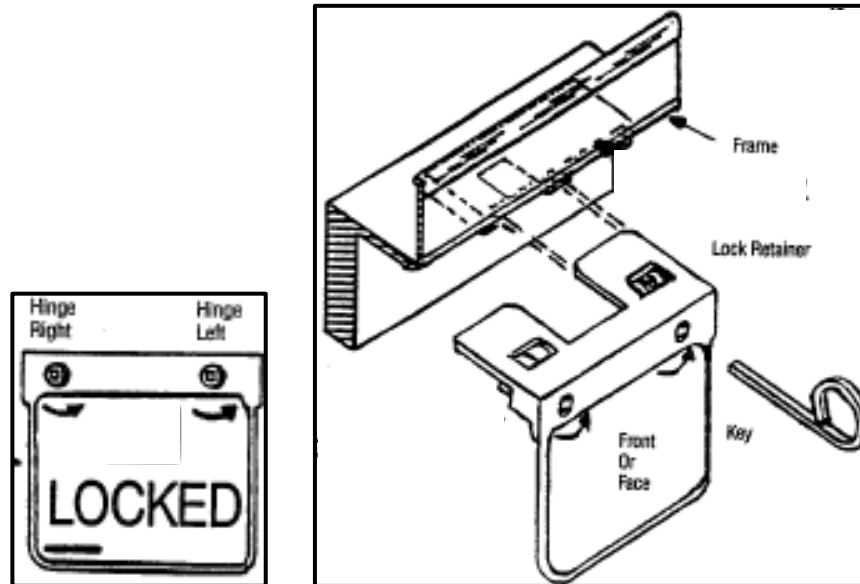

7. Remove key.

8. To remove P.O.M. Lock, insert key into square lock hole and turn the key clockwise.

34. Model 101 Glass Replacement (Reglazing)

1. To remove torque rod from door, drive tapered shaft of torque rod from door.

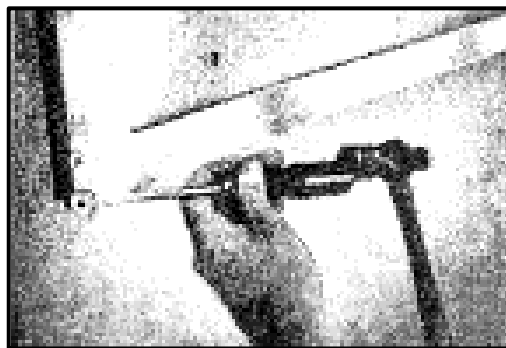

2. Starting at corner of door, remove gasket and plastic from all four sides of door.

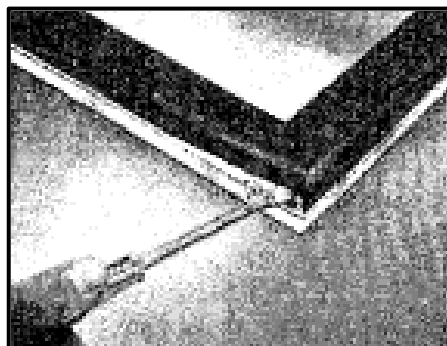

3. For models prior to 1987, unscrew SJ cord retainer to expose heating element wires. For models after 1987, remove top or center access plate. Unsnap hinge pin from female socket and remove, or unplug hinge pin lead wires to remove hinge pin. If heated glass is used, cut Black and White lead wires to glass. Remove heating element from door.

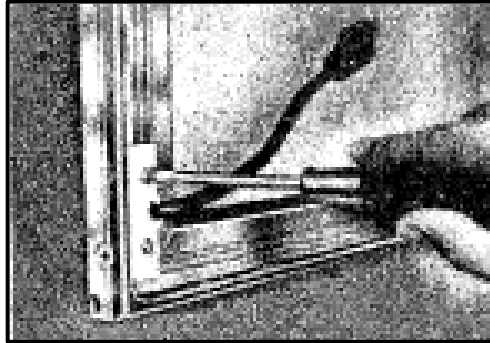

4. Using a square-head or clutch-head driver, remove screws on both side rails only. Remove top and bottom door rails first.



5. Drive rails from glass, using mallet and block, always starting at corner of door.



6. Once rails have been removed from glass, re-insert new friction-fit glazing channel on new glass and drive rails onto glass.

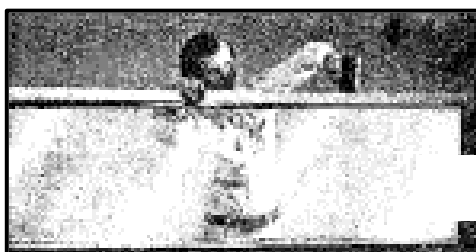

- After both long rails have been affixed to glass, re-insert friction-fit glazing channel on top and bottom and tighten miters with square-head or clutch-head driver.

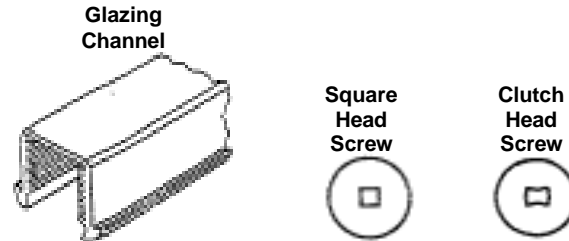
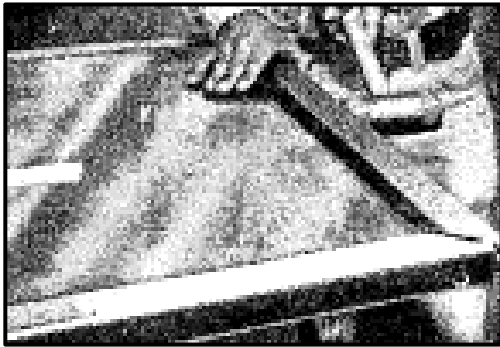

- Once all four (4) door rails have been affixed to glass, measure diagonally to make sure door is in square.

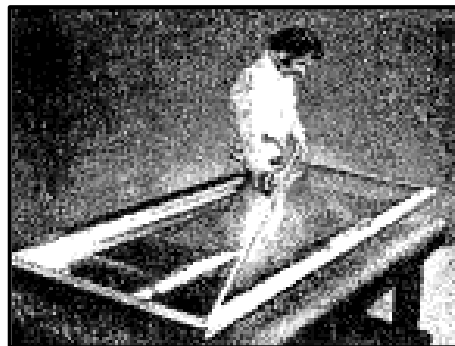

- After replacing the glass unit, and when door rails are in square, re-insert heating element wires in door rail channels and repeat process. Replace gasket and retainer strips.

To re-install torque rod, align torque shaft with key way in door and drive tapered shaft flush with bottom of door rail.

Note: If heated glass is used, when disassembling door, cut Black and White lead wires to glass. When rebuilding door, pull glass heater leads out through heater access hole before assembling top or side door rails. Re-connect Black and White lead wires to heater wire Black and White lead wires. On newer models, re-connect hinge pin to heater receptacle or heater lead wires.

- When replacing heated glass, bus bars on glass (colored bars on top and bottom of glass or up and down the sides) must go to the front of door, or customer side. This is the heated side.
- For questions about glass replacement, call Anthony's Customer Service or local Sales Representative.

35. Ordering Replacement Frames

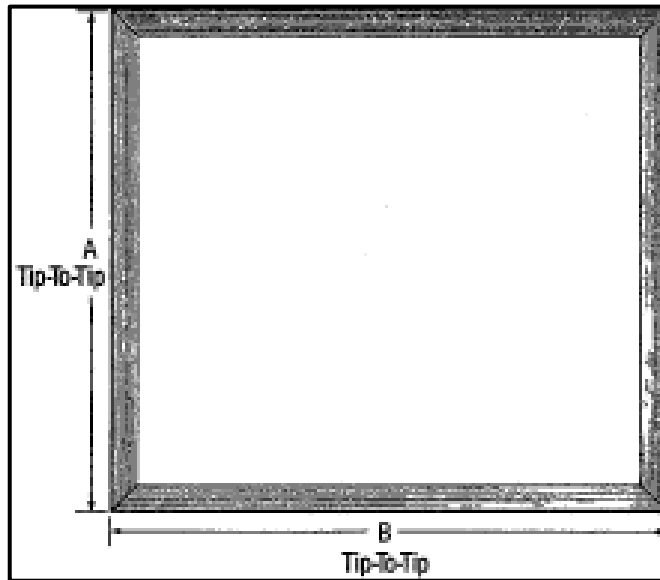

Replacement Frames (All Swing Doors)

1. Specify outside tip-to-tip dimensions of frame. Measure to nearest 1/16".
2. Specify date of original manufacture and/or Anthony confirmation/invoice number.
3. Specify Cooler or Freezer.
4. Specify door size (width and height).
5. Specify finish (smooth/serrated/gold/silver/black, etc.).
6. Specify Model number.
7. Specify left or right hinge swing.
8. With or without heaters?
9. With or without lights?
10. With or without locks?
11. Specify any custom items on original order.

36. Frame Heater Wire Replacement

1. Remove door from frame, following previous instructions for door removal.
2. Insert small flat-head screwdriver under back side edge of contact plate retainer and lift up to remove.

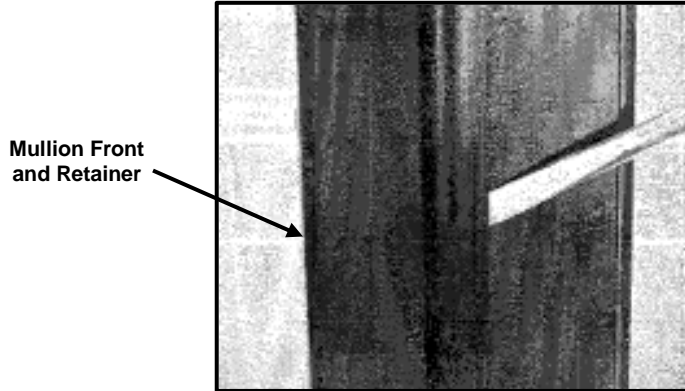

3. Remove contact plate to expose heater wires.

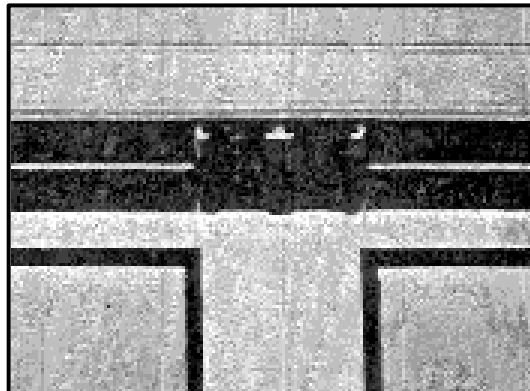

4. See following page for frame heater schematics.
5. Cut heater at the lead wire and pull heater out of track.

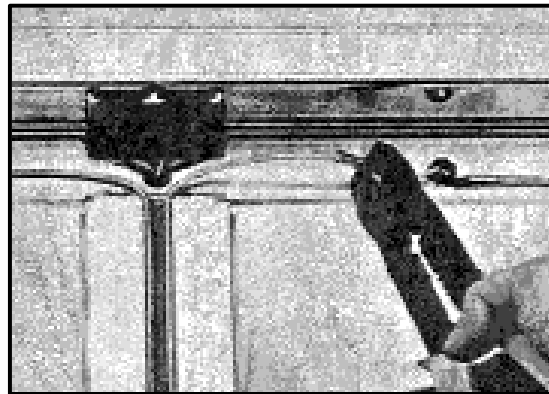
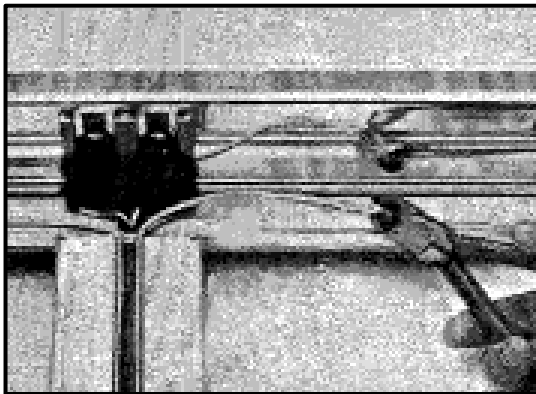

- 6. When ordering replacement heaters, specify which heater needs replacing: top, bottom, end or center mullion heater. This varies depending upon the particular frame make-up..
- 7. Reverse instructions to re-install heater.

37. Models 101 & 2100 Frame Heater Schematic/Low Temp

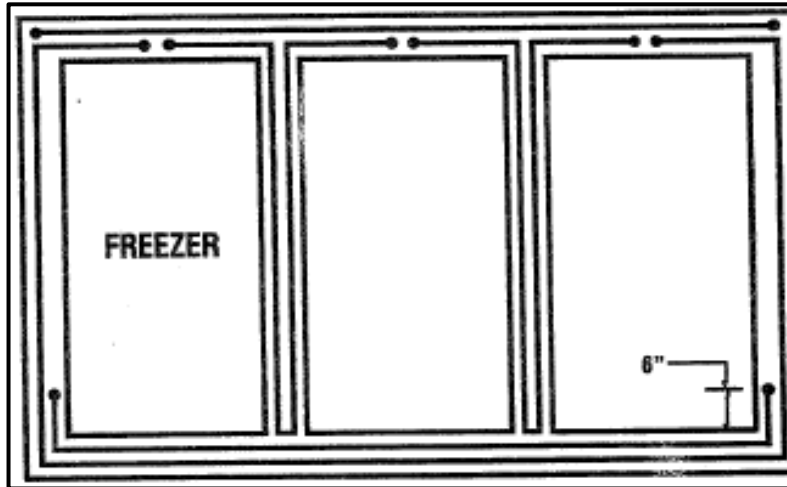

3-Door Frame (Typical for 2 Thru 5 Doors)

Heater Wire Layout:

Bottom and End – Perimeter –

Center Top Supplement – Bottom Supplement.

Note: Top Heater to be installed before door sockets are set in place.

38. Models 101 & 2100 Frame Heater Schematic/Normal Temp

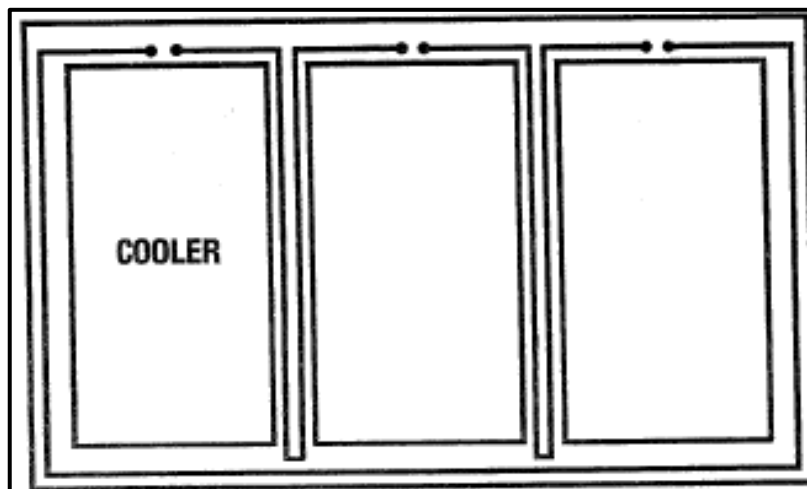

3-Door Frame (Typical for 2 Thru 5 Doors)

Heater Wire Layout:

Bottom and End – Perimeter and Center

39. Humastat Installation Procedure

1. Install Humastat Power Junction Box before refrigerator door power wiring, on the inside wall of refrigerator.

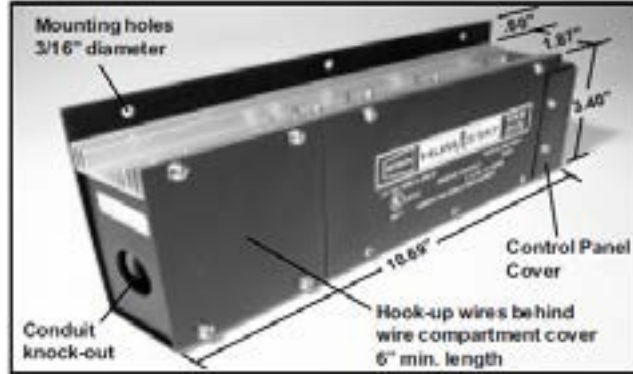

2. Remove wiring compartment covers by removing four (4) sheet metal screws.
3. Connect heater hot wire to Red wire from control unit.

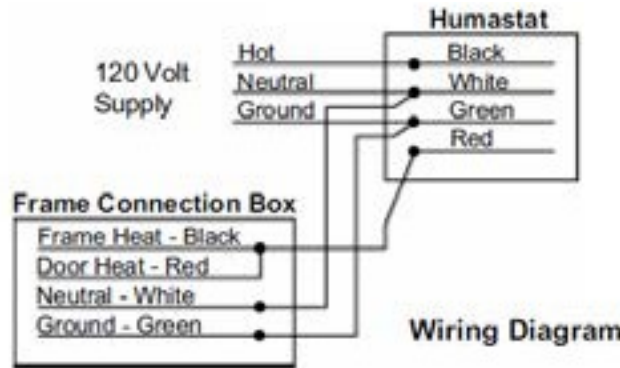

4. Connect input power hot wire to Black wire from control unit.
5. Connect all White wires, including common side of power line, line load and control unit White wire.
6. Connect Green Ground wire from control unit to Green Ground wire at frame and to incoming Ground wire (if furnished).
7. Replace the Wiring Compartment Cover with the sheet metal removed in No. 2 above.

- 8. Install Humastat Sensor on the outside wall of refrigerator above the door frame, within three feet of power junction box.

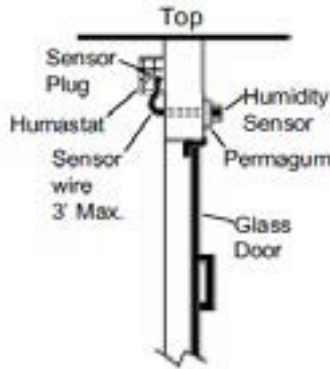

120 VAC 50/60 Hz, 20 Amperes Maximum

- a. Drill a 1/4" diameter hole through refrigerator wall directly above the door frame.
- b. Use the wood probe supplied with the sensor to feed the sensor wire through the refrigerator wall.

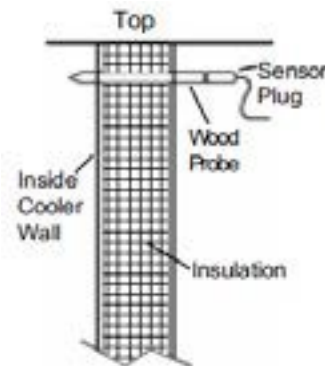

- c. Apply permagem to back of sensor around the wire. Pull the wire through the hole until the sensor makes close contact with the wall and secure it to the wall with the screws provided Seal the probe wire with the permagem on inside of wall.
- 9. Remove wood probe from sensor connector by holding the body of connector securely and pulling off the probe.
 - 10. Insert the sensor plug into the sensor jack on the outside end of the power junction box.
 - 11. Set the heater control knob for the lowest value which keeps the door free of undesirable moisture.

Model 101/2100 Doors Service & Installation

- Red light indicates when heaters are functioning.

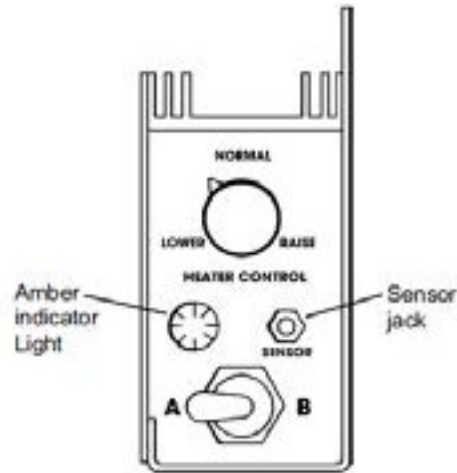

Control Panel End View

Switch shall remain in Position "A" for normal operation

40. Model 101 Humastat

- Sensor is prewired in frame mullion.
- For Low Temp applications, see Sensor Part #F-161.
- For Normal Temperature applications, see Sensor Part #F-1649.

41. Model 101 & 2100 Shelf Assembly Catalog Size/Shelf Size

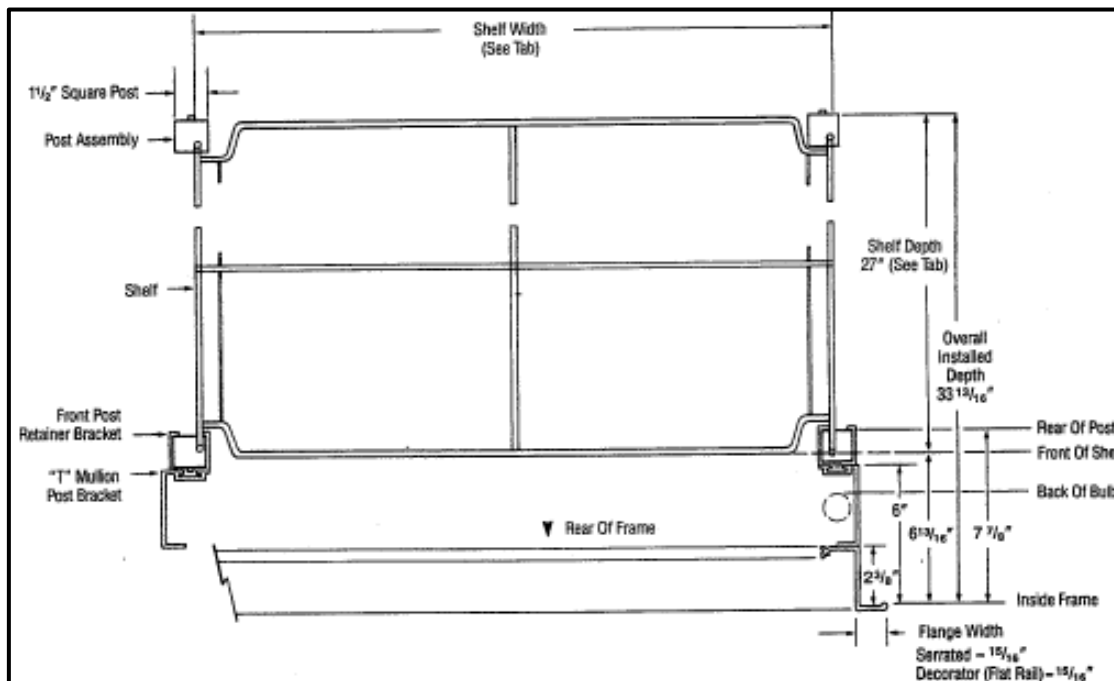

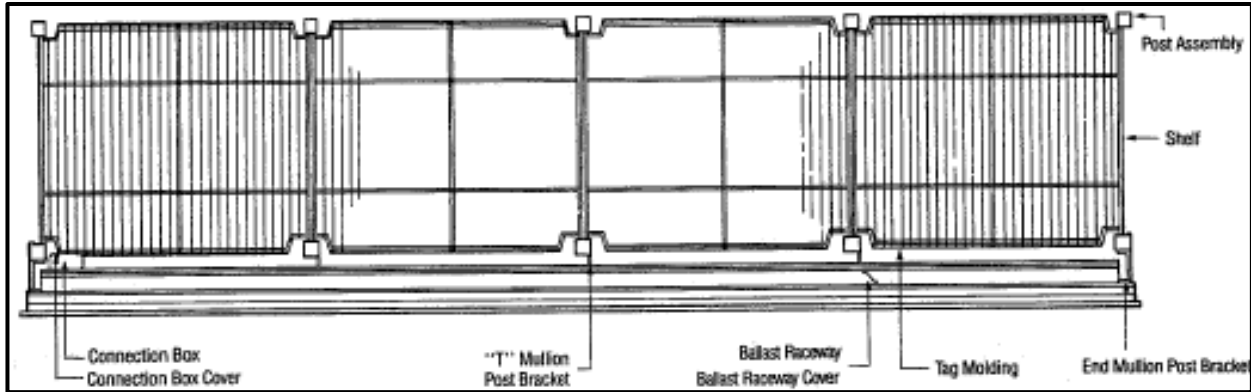

Shelf Tabulation		NOTE: For 24" 1- and 2-Door Frames, use shelf size 22 9/16" x 27" For 3 Doors or more, use 23 5/16" x 27"
Catalog Size	Shelf Size	
24"	23 5/16" x 27"	
26"	26 5/16" x 27"	
30"	29 13/16" x 27"	

42. Models 101 & 21 00 Frame & shelving with Standard Lighting

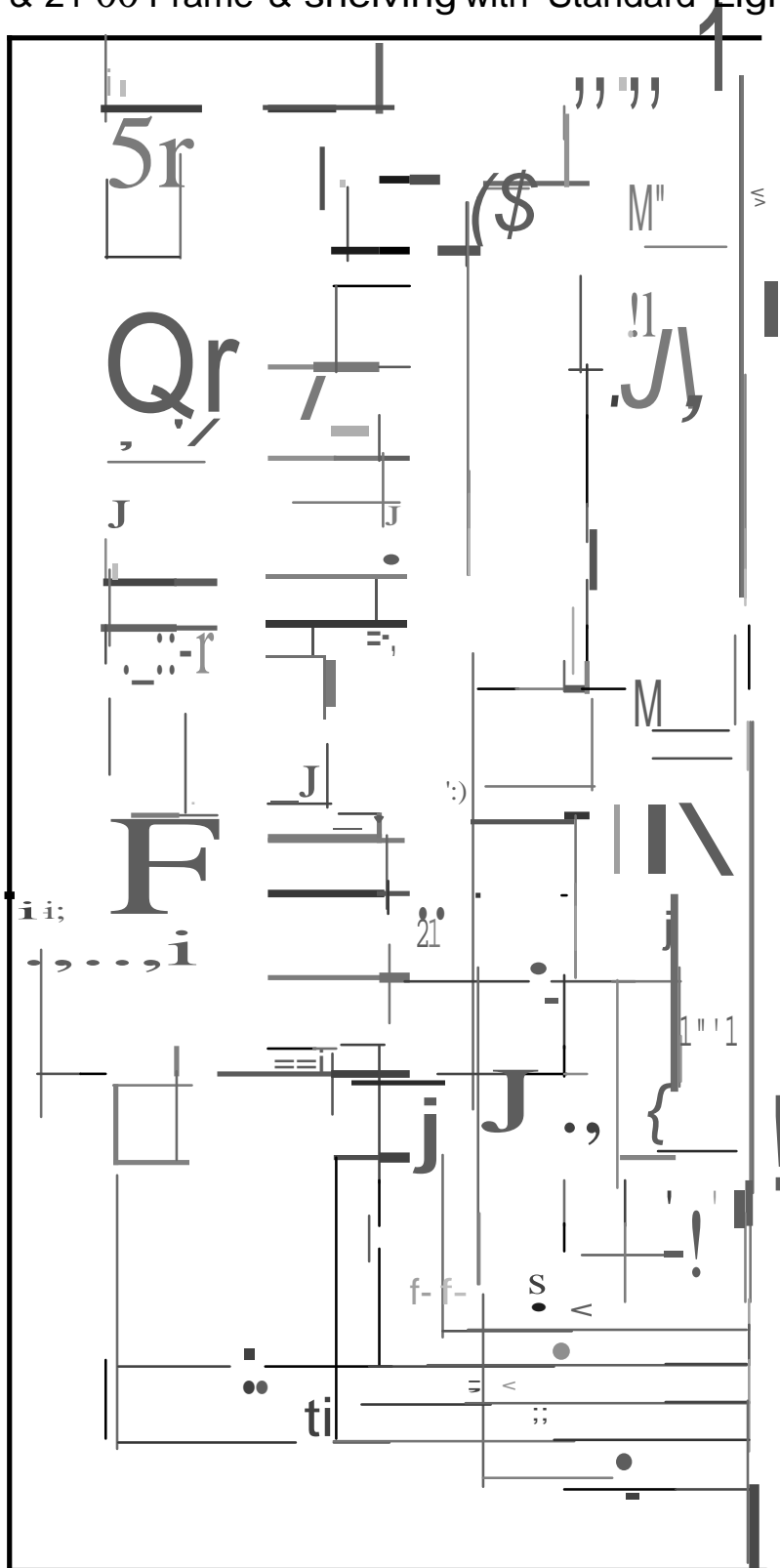

43. Models 101 & 21 00 Frame & shelving with "ELS" Electronic Lighting

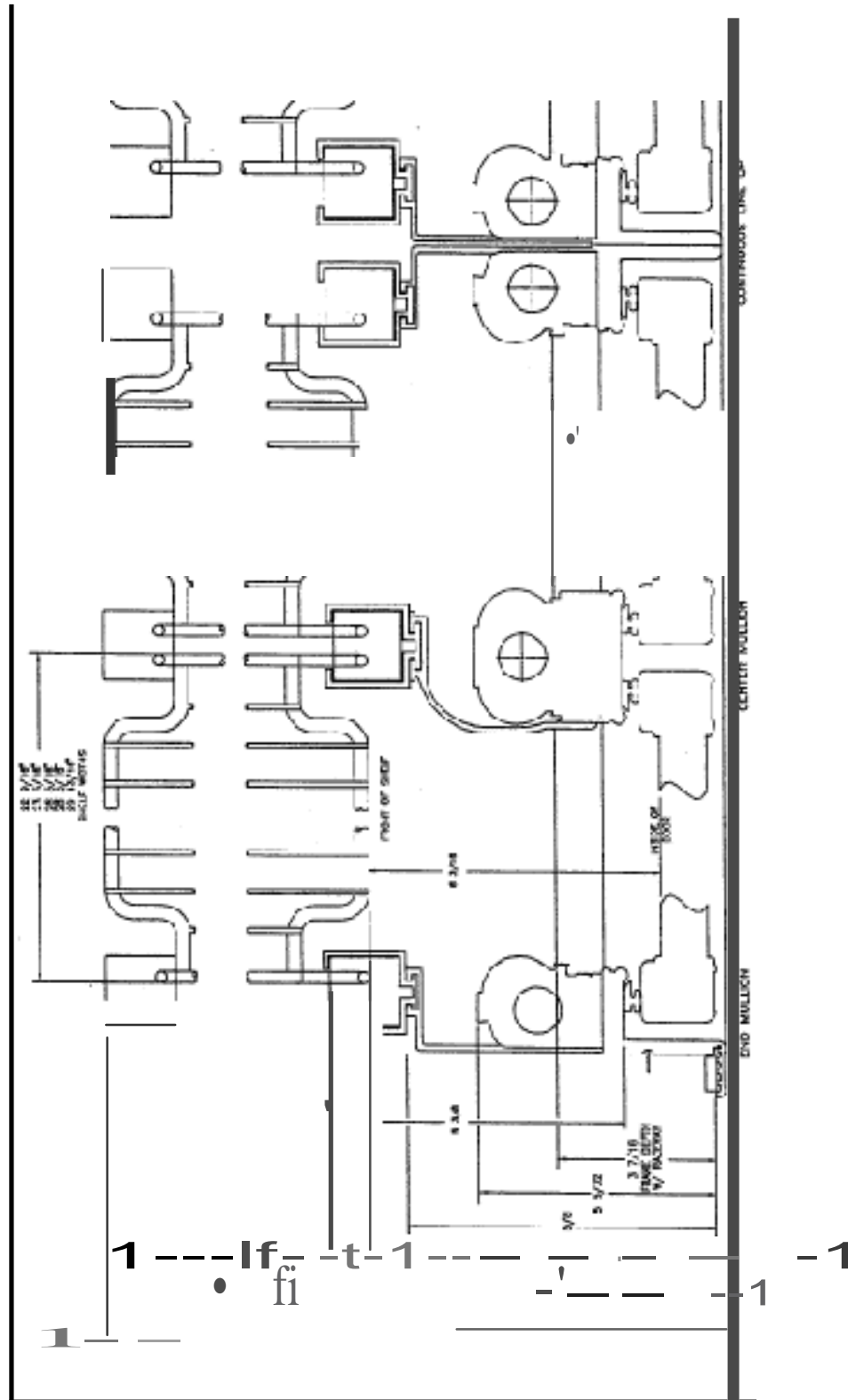

TITLE:

44. Four-Post Stabilizer Bar Installation

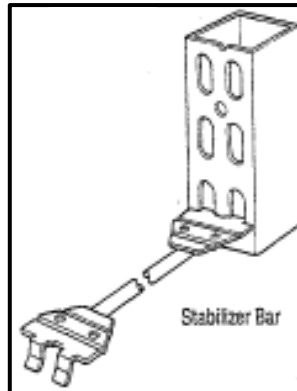

1. The four-post stabilizer is designed to help support the posts during installation and stabilize the system while in use.
2. Insert the forked end of stabilizer bar into the elongated holes in post.
3. Install the post stabilizers on the top and bottom of all posts, front to rear, before installing shelves.

45. Four-Post Shelf System Installation

1. Attach post to inside frame by inserting post key into frame retaining bracket.

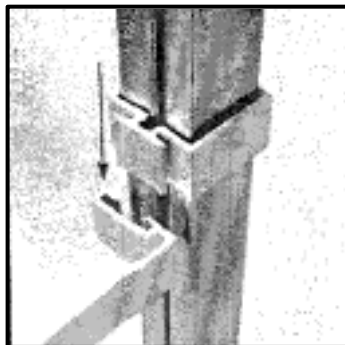

2. Before installing shelves, adjust all front posts to equal heights with leg leveling bolts at bottom of posts.

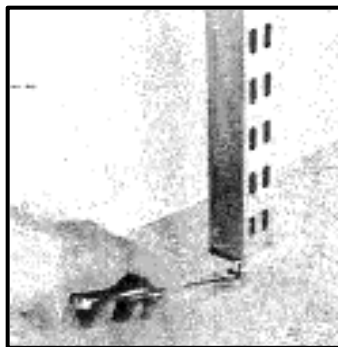

3. Insert front of shelf in front post at angle as shown, then position rear shelf posts.

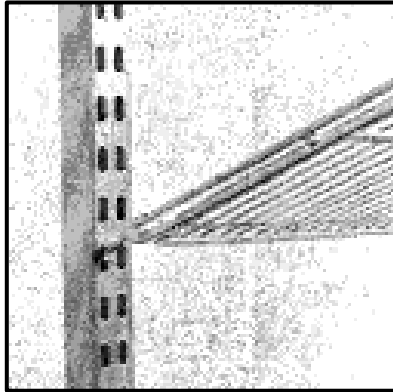

4. Drop rear of shelf down and pull back in slot on rear posts. Continue to add shelves behind each door, spacing for desired product merchandising.

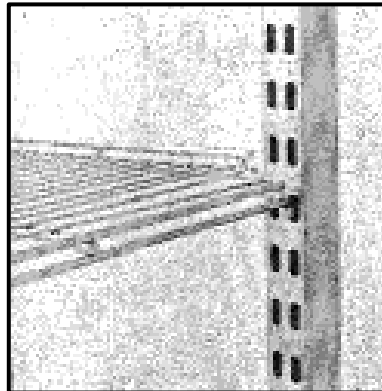

5. After installing shelves, adjust rear post leveling bolts to level. The Four-Post Shelf System is now ready for merchandising.

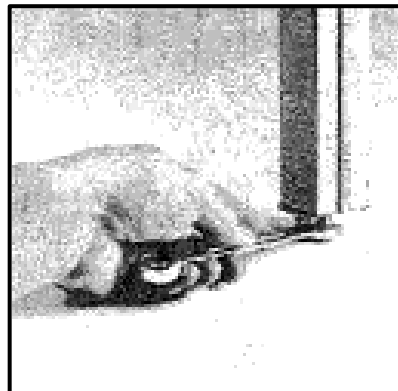

46. Plastic Tag Molding Installation

1. Tag molding is the exact length of the shelf's upper front bar. Center tag molding on front of shelf. Hook bottom of tag molding under shelf across entire width of shelf. Spread thumbs across tag molding and push up.

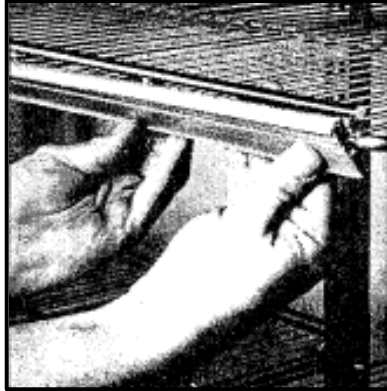

2. Snap top corner of tag molding strip onto shelf front. Apply even pressure across top of tag molding as it is fed onto top horizontal bar on shelf front.

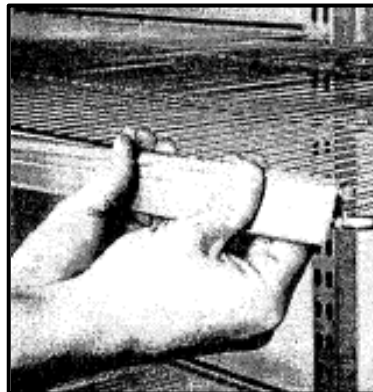

3. For replacement tag molding, specify width of shelf when ordering.

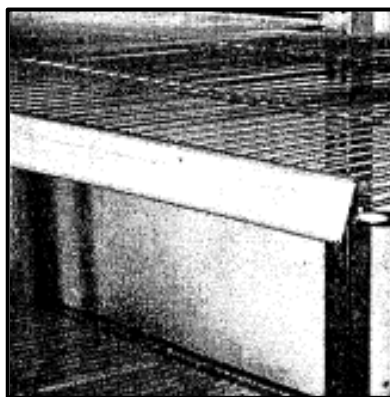

47. Model 2100 G.F.I. Location & Wiring Diagram

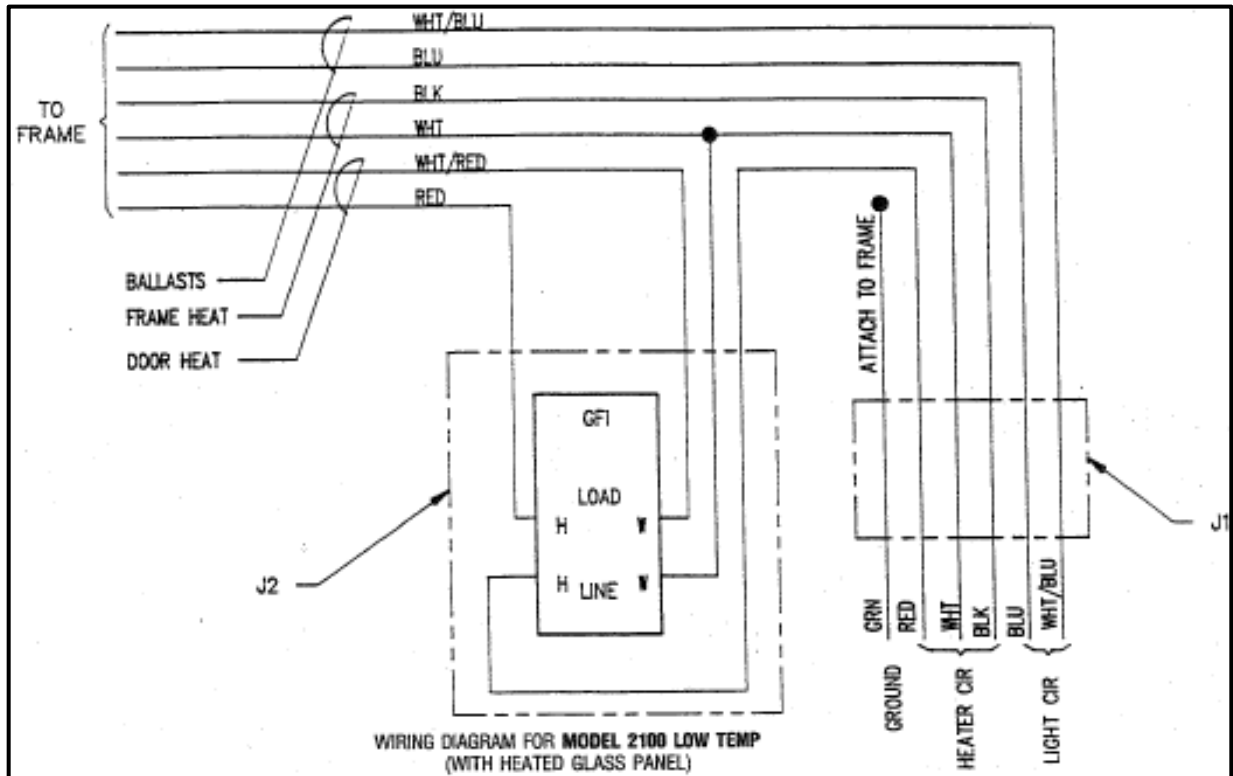

48. Lamp Replacement

1. Lift lamp up into top plunger socket, then out at bottom to remove.

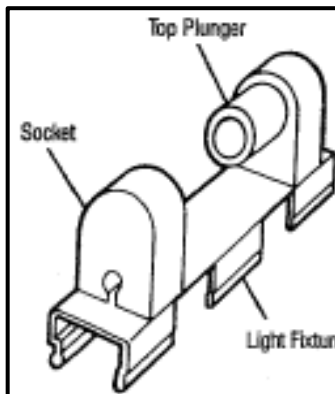

2. Pull end caps off end of light shield, then remove bulb from shield.
3. To replace bulb, insert new bulb into lamp shield and snap in end caps. To replace lamp, lift bulb up into top plunger socket, then set into bottom socket. **Do not install lamps without lamp shield.**

49. Lamp Socket Replacement

1. To replace sockets, remove lamp, then pull top socket down and pull out of “D” hole. To replace bottom socket, pull socket up and out of “D” hole. Extra lead wire is left in the mullion for easy replacement.

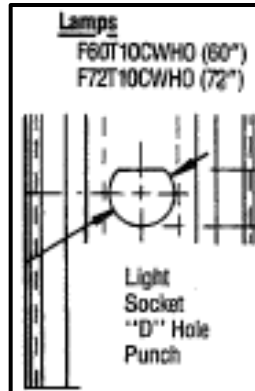

2. Pull sockets out, then cut lead wires.
3. Reverse instructions to replace.
4. To re-install sockets, insert top front metal tab into “D” hole and snap socket up. For bottom socket, insert metal tab into “D” hole and snap socket down to install.
5. Replace lamps.
6. ***For safety and efficiency, lamps should never be installed without shields.***

50. Recessed Light Socket Replacement

1. Remove safety clips and light guard.

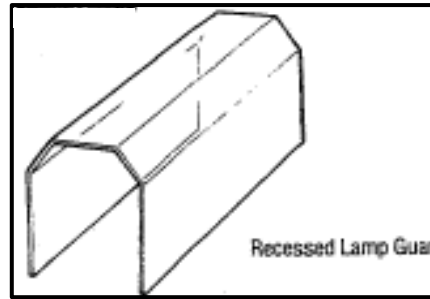
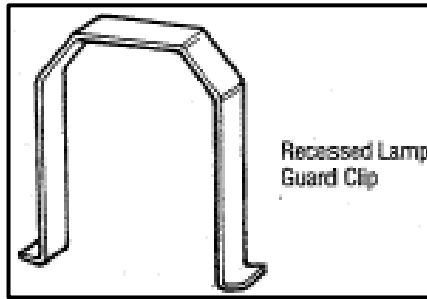

2. To remove top socket (plunger socket), pull socket down then out.

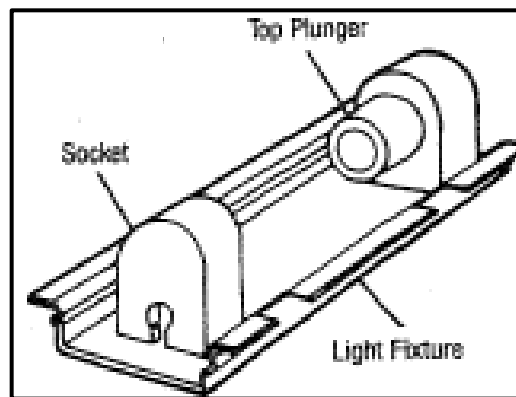

3. To remove bottom socket, pull up then out.
4. Mullion contains excess socket lead wire. Cut lead wires to sockets.
5. Re-wire new socket in place.
6. To re-install sockets, reverse above instructions.
7. Replace bulbs and lamp guards.

51. Recessed Lamp Channel Replacement with Remote Ballast

1. Insert flat-head screwdriver under back edge of light channel retainer to remove.

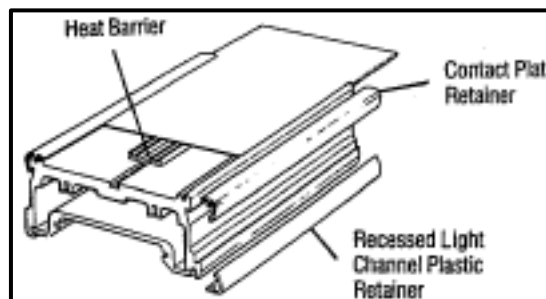

2. To replace, lay light channel into mullion, then snap on retainer as shown.

52. Recessed Lamp Guard Replacement with Remote Ballast

1. Compress metal safety clips on each end and in the center of light guard to remove.

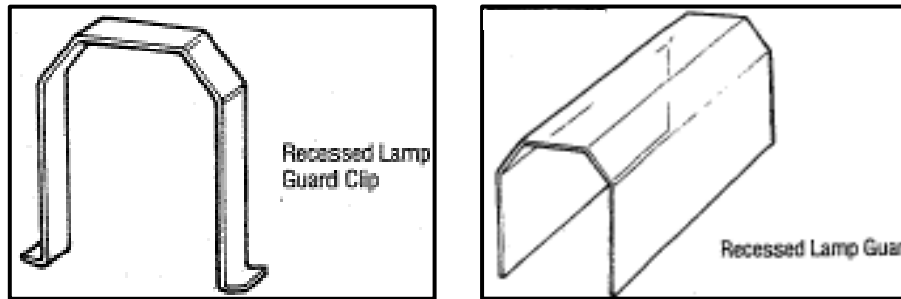

2. Lift light guard up to release from lower shield clip, drop down to release guard from top clip.
3. To replace, insert guard into bottom clip first, then into top clip. Compress metal safety clips when they're put into recessed channel. Release to let clip seat into groove in recessed channel.
4. To replace end plastic clips, compress sides and pull out.
5. To replace end clips, compress new end clip and insert into access groove in light channel.

53. Recessed Lamp Replacement

1. Remove light guard per previous instructions.
2. Lift bulb up into top plunger socket and pull bulb out and down at bottom to remove.
3. To replace bulb, insert bulb into top light socket and set into bottom socket.
4. Re-install light guard and clips.

54. "Boost & Buck" Transformer Wiring Diagram

1. Recommended wiring for 110/120 volt applications.

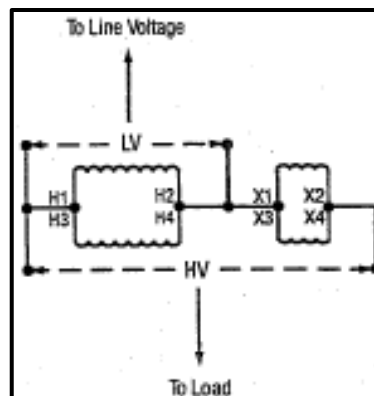

- 2. Transformer, wired as follows, will increase the 115 volt line voltage by 10% and the applied heat by 20%.
- 3. Hot to H1-X3.
- 4. Neutral to H2-X1-X3.
- 5. Load for heaters X2-X4.
- 6. Transformer is rated for an 18 Amp load.

55. Frame Junction Box Wiring (Standard Production)

- 1. Remove cover.

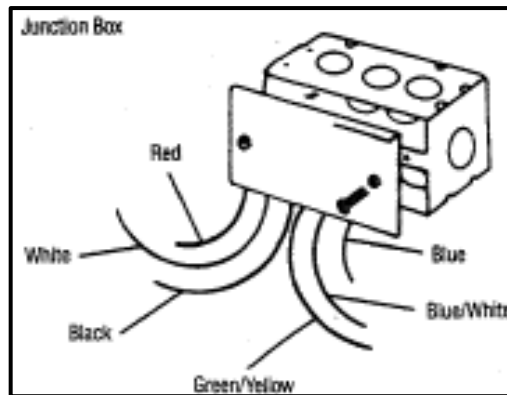

- 2. Wires are marked as to application.
 - 1-Black for frame heat.
 - 1-Red for door heat.
 - 1-White, common for Black and Red.
 - 1-Blue for lights.
 - 1-Blue/White common for lights.
 - 1-Green/Yellow for ground.

56. Models 101 & 2100 Light Fixture Placement (Prior to 10/93)

Pre-wired lighting uses only 1-light ballasts. Non pre-wired uses 1- or 2-light ballasts.

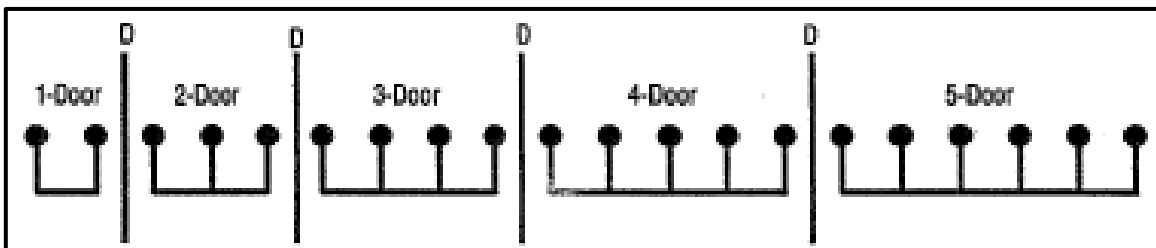

Frame Breakdown – Each Frame Section with Full Flange

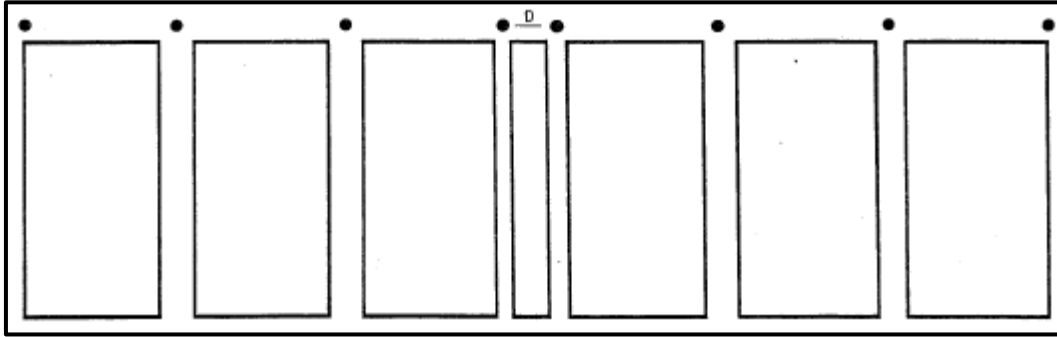

● = Light
 X = No Light
 D = Wood Divider

Example: 6-Door Lineup (2 sets of 3) of Model 101 or 2100 with Full Flange

57. Models 101 & 2100 Light Fixture Placement – “Continuous” Lineup (10/93 to Present)

Pre-wired lighting using 1- or 2-light ballasts. Continuous lineup with “E.L.S.” lighting.

● = Light

Frame breakdown: 1 set of 6 (2 sets of 3, joined with six bolts).

Note: Lamp at each end of frame and on each mullion.

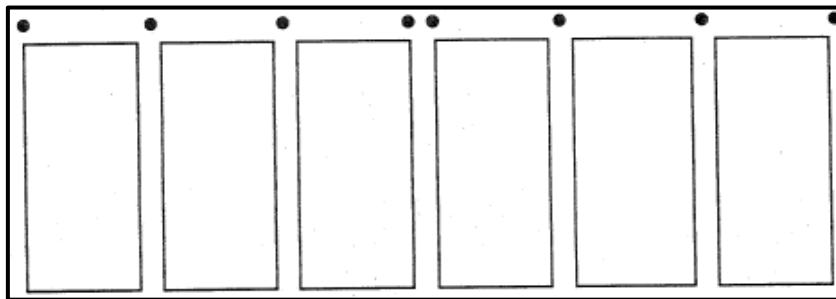

Pre-wired lighting using 1-light ballasts. Continuous lineup with **standard lighting**.

Frame breakdown: 1 set of 6 (2 sets of 3, joined with six bolts).

Note: One more lamp than number of doors.

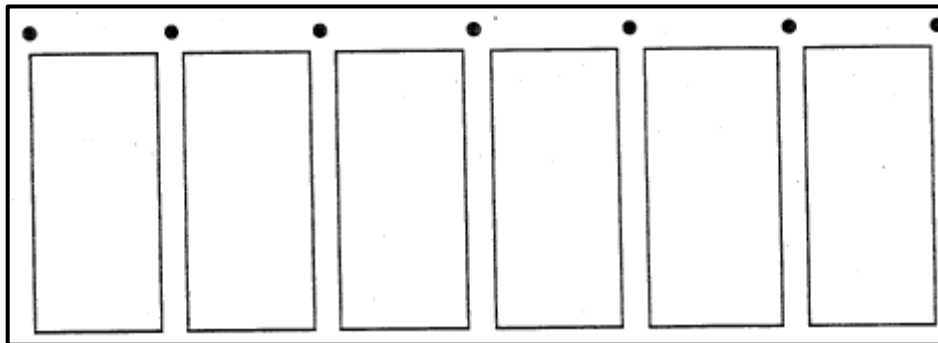

58. Models 101 & 2100 Low Temp 120-Volt Remote Ballast and Lamp Wiring Diagram for 1-Light Systems

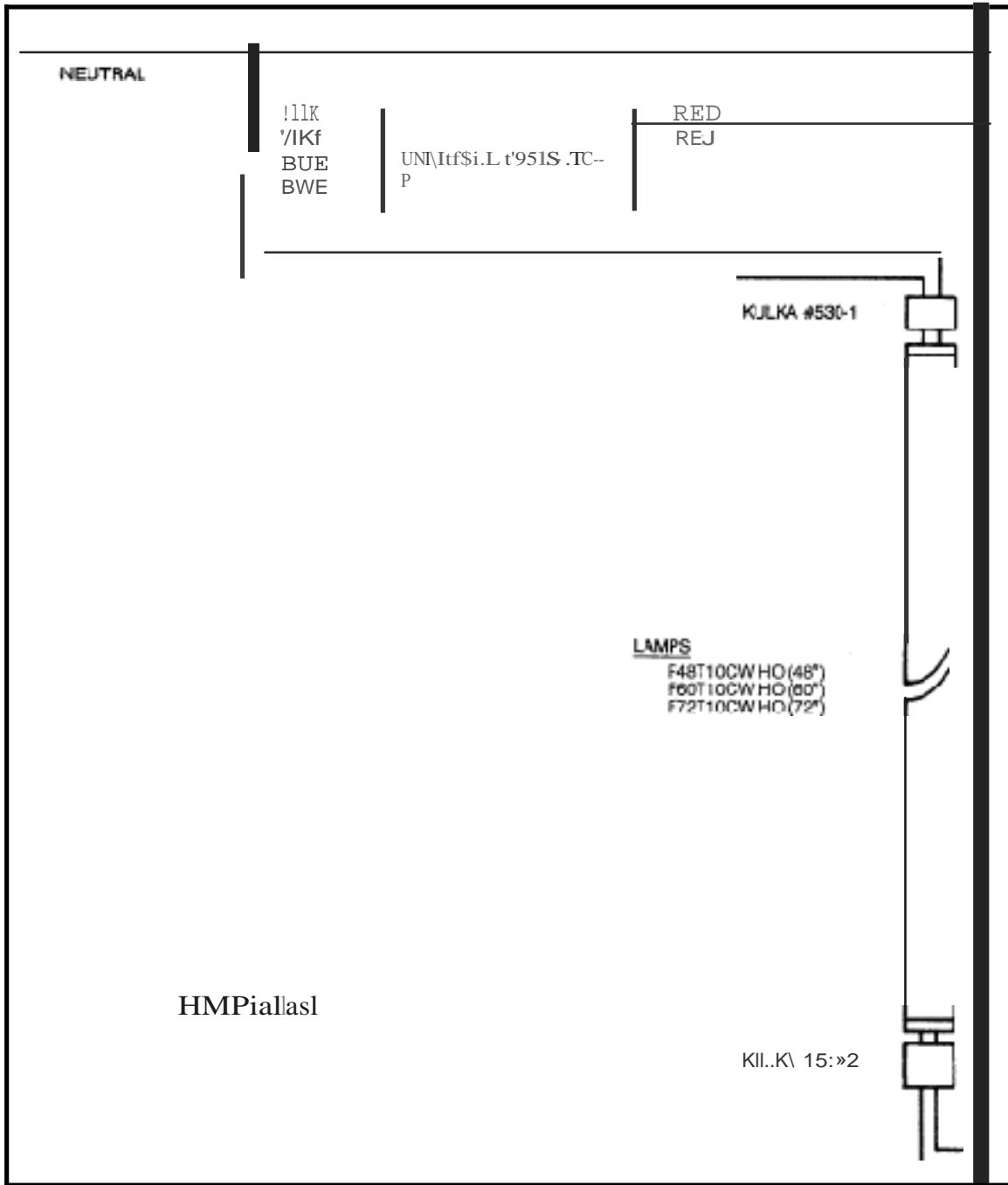

Model 101/2100 Doors Service & Installation

TITLE:
99-13312-8001 Model 101/2100 Doors Service & Installation

|||||
B

Page 53 of 95

TITLE:
99-13312-S001 Model 101/2100 Doors Service & Installation

REV.
B

Page 54 of 95

59. Models 101 & 2100 Low Temp 120-Volt Remote Ballast and Lamp Wiring Diagram for 2-Light Systems

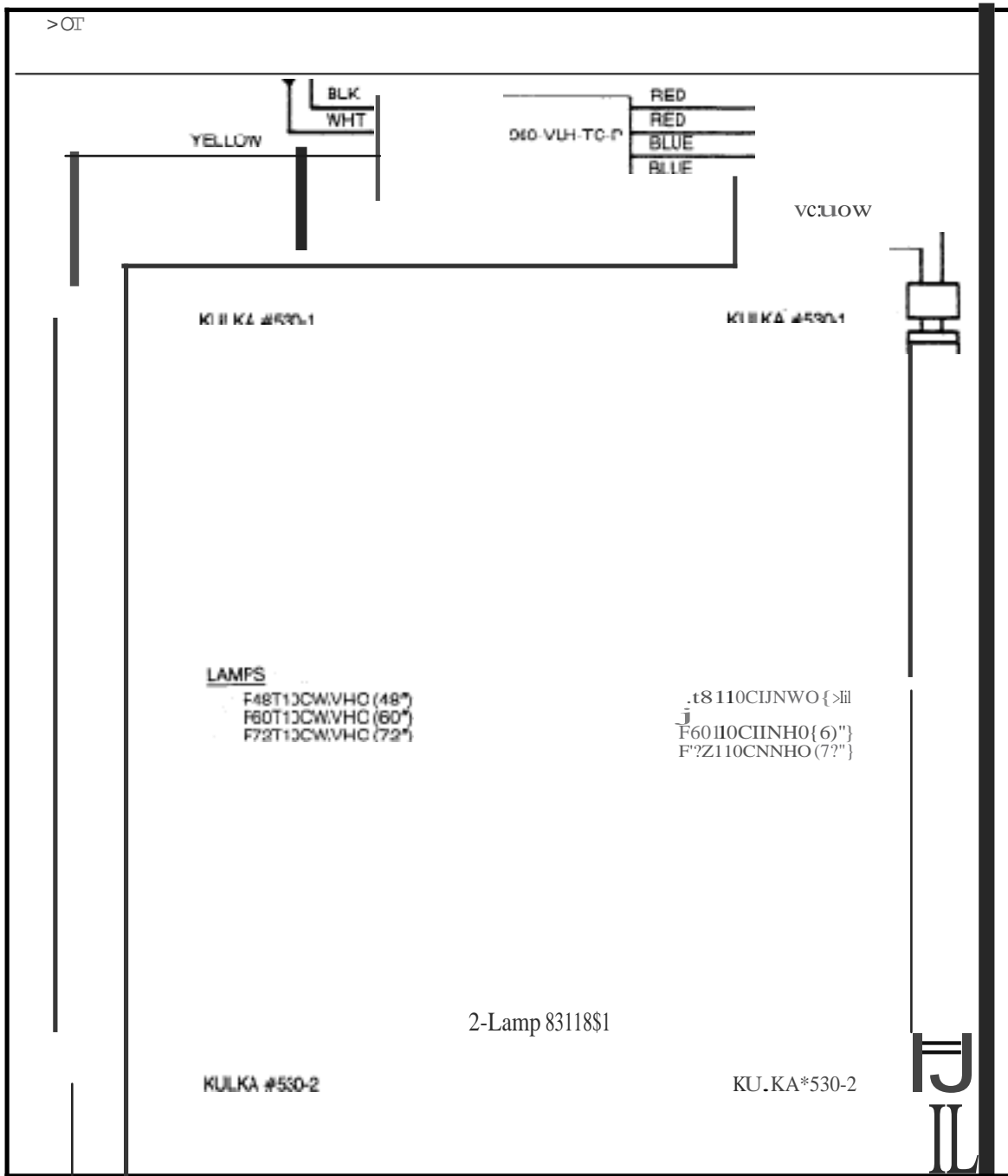

Model 101/2100 Doors Service & Installation

|||||
B

54 95

60. Models 101 & 2100 Normal Temp 120-Volt Remote Ballast and Lamp Wiring Diagram for 1- & 2-Light Systems

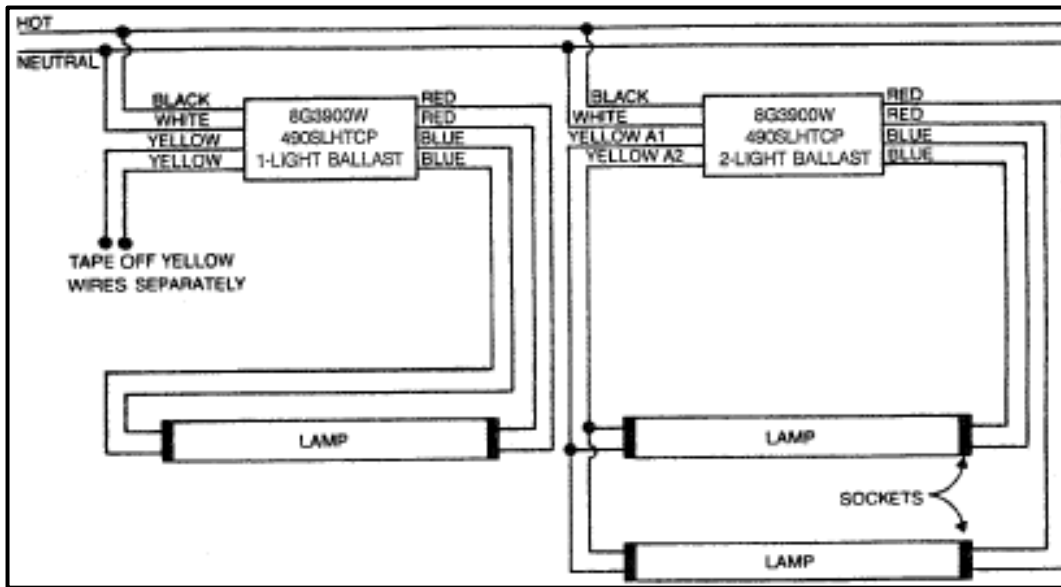

Lighting Diagram for 1- & 2-Light Ballast

61. Models 101 & 2100 Normal Temp 120-Volt Remote Ballast and Lamp Wiring Diagram for 3-Light Systems

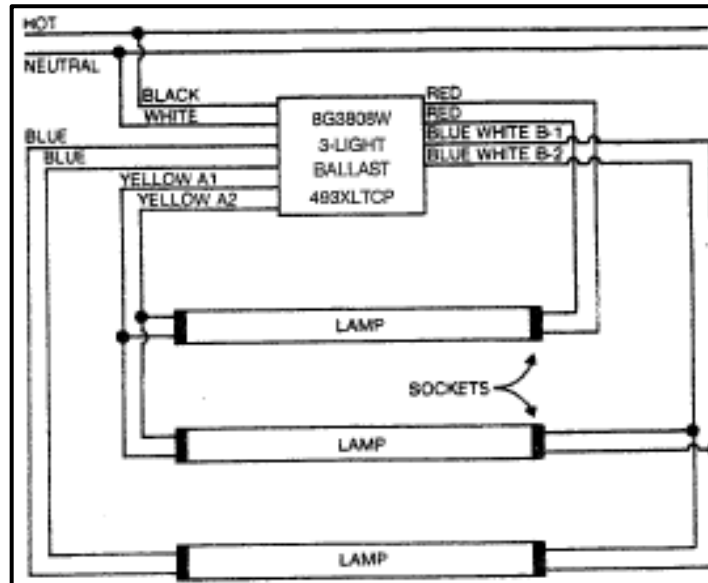

Lighting Diagram for 3-Light Ballast

62. Normal Temp & Low Temp 120-Volt Ballast and Lamp Wiring Diagram - Pre-Wired 1-Light System

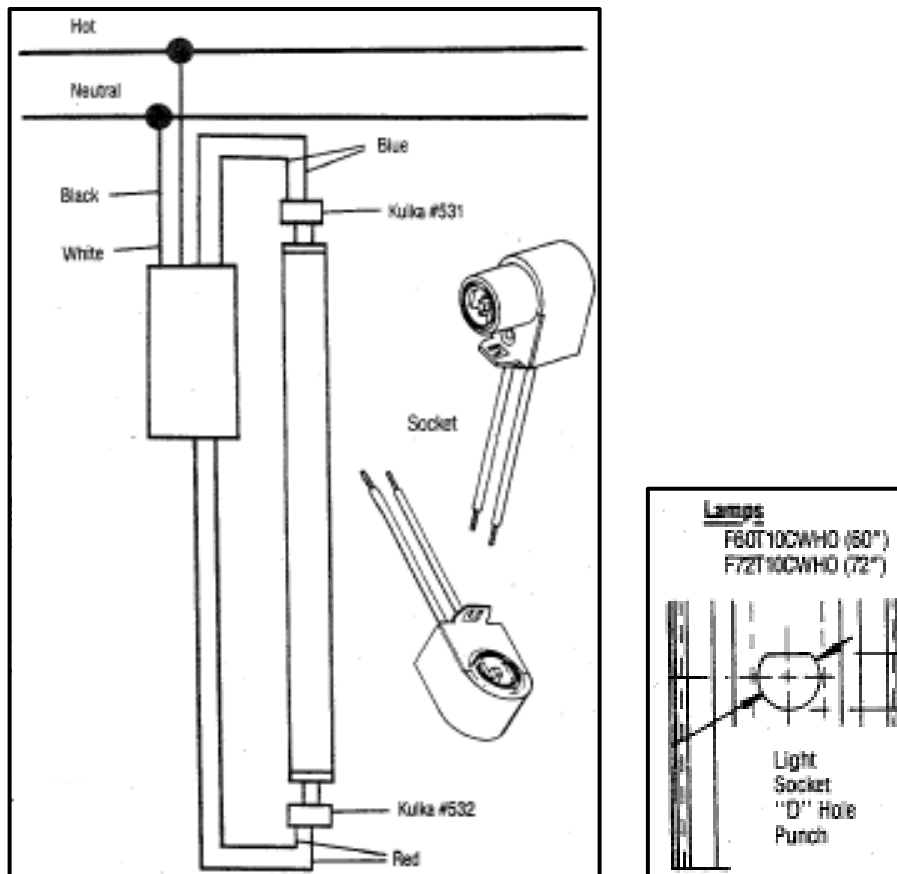

Wiring:

1. Ballast has two (2) Red wires, two (2) Blue wires, a Black and a White wire.
 - a. Wire two (2) Red wires to two (2) Red wires on bottom socket.
 - b. Wire two (2) Blue wires to two (2) Blue wires on top socket.
 - c. Black wire goes to hot, White wire goes to neutral.

63. Ballast Replacement

1. For replacement ballast, ***always use ballast number from existing ballast.***
2. Remove door from frame opening.

3. Insert flat-head screwdriver under back edge of contact plate retainer to remove.

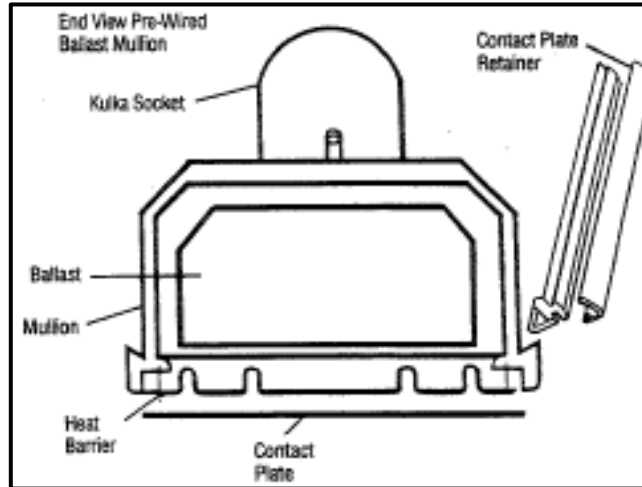

4. Remove contact plate from mullion.
5. Pull heat barrier from mullion to remove.
6. The ballast has a wiring diagram on its face. To replace ballast, cut lead wires: 2-Red, 2-Blue, 1-Black and 1-White.
7. Follow color codes to rewire ballast. Reverse instructions to replace heat barrier, contact plate and contact plate retainer.

Note: When the two (2) Blue and two (2) Red wires are connected to the top and bottom sockets, make sure the wiring is one-to-one. **Do not gang wire.**

64. “ELS” Lamp Socket Replacement

WARNING: *Before servicing Anthony doors make sure all power to case is off. Always use a qualified electrician.*

1. Remove front contact plate retainer.

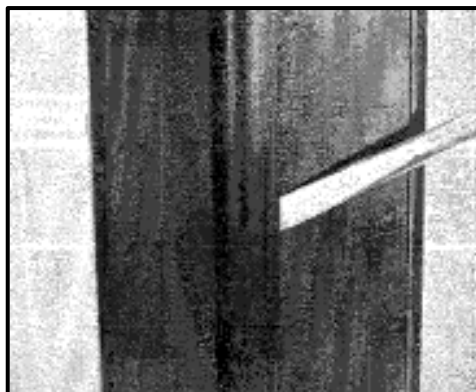

2. Remove contact plate.

3. Remove top and bottom spring steel clips. Insert small flat-head screwdriver under clip to release clip from side of fixture. On one side at a time, pull clip out of pre-punched holes in side of mullion.
4. Gently pull clips away from fixture and **set clips aside for re-installation**.
5. **Remove “ELS” lens.** Starting at the top, pull lens away from front of light fixture, next to frame mullion. (If necessary, a small flat-head screwdriver can be inserted between lens and back mullion plastic to ease lens out of groove.) **There is no need to remove lens from the bridge.** (The “bridge” is the black or clear plastic piece connecting the two lenses at the back of the fixture.)

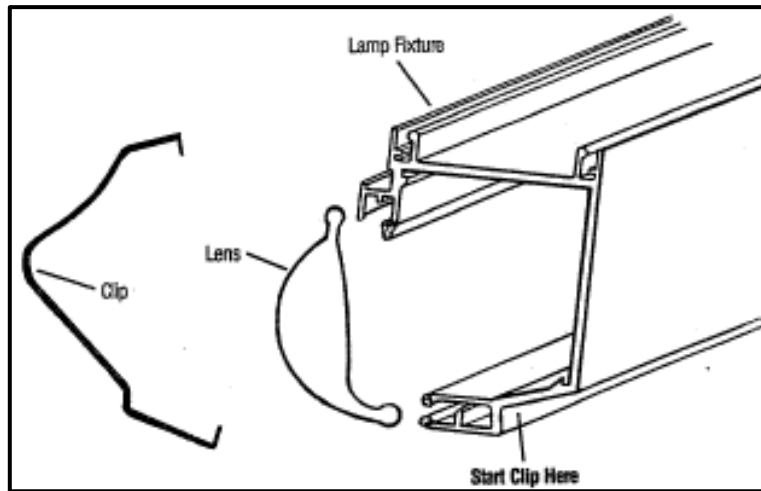

6. Remove bulb.
7. From the front of the socket, depress both sides of socket and push socket out through front of mullion.

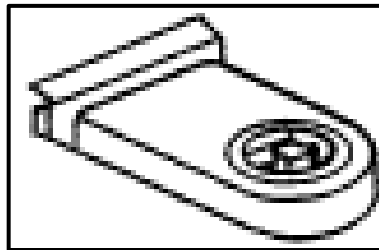

8. Cut ballast lead wires to socket as close to socket as possible.
9. To replace a socket, insert socket into access hole in mullion and push until tabs on side of socket snap in place on back side of mullion.
10. Insert ballast lead wires into socket connections.
11. Re-install bulb, lens and front contact plate.

65. “ELS” Electronic Ballast Replacement and Wiring Instructions

WARNING: *Before servicing Anthony doors make sure all power to case is off. Always use a qualified electrician.*

1. Refer to drawings on following pages for ballast location and wiring.
2. Remove door that hinges on mullion where ballast will be replaced.
3. From front of frame, remove contact plate and retainer by inserting a flat-head screwdriver under back edge of black contact plate retainer, and gently pull to unsnap retainer from mullion. Repeat from other side of mullion and remove contact plate.

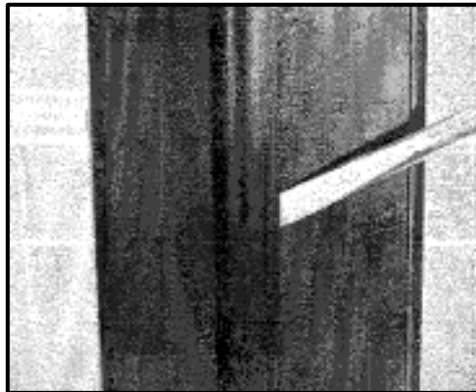

4. With ballast now exposed, remove screw on top end of ballast. Slide ballast up and out of punched mullion tabs.

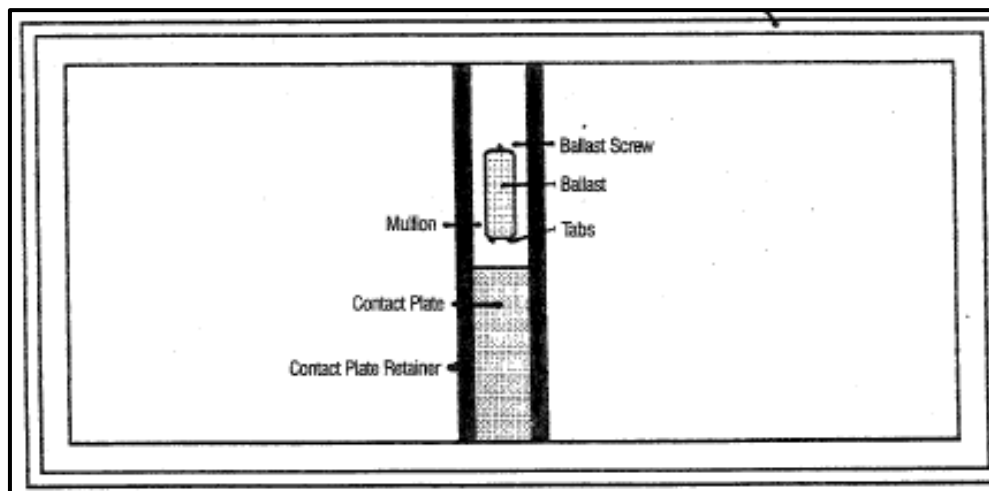

5. Disconnect or cut all lead wires. If cut, leave enough lead wire to re-connect new ballast with wire nut.
6. Insert bottom of new ballast in punched tabs on mullion. Re-install top screw in top end of ballast.

Model 101/2100 Doors Service & Installation

7. Re-connect new ballast lead wires using the following Wiring Diagrams:

- 2-Light (1-Door)
- 3-Light (2-Door)
- 4-Light (3-Door)
- 5-Light (4-Door)
- 6-Light (5-Door)

8. Lay contact plate flat on mullion. Staring at the top, insert contact plate retainer into front edge of mullion. Snap retainer on back edge of mullion. Repeat instructions for opposite side.

120V Electronic Ballast Wiring Diagrams

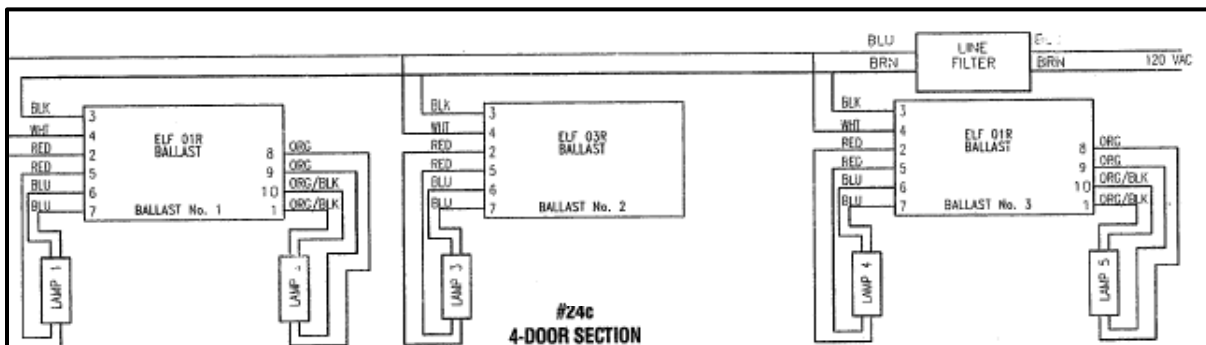
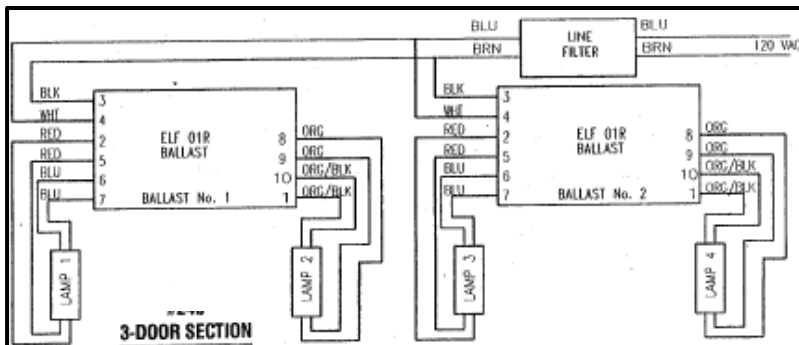
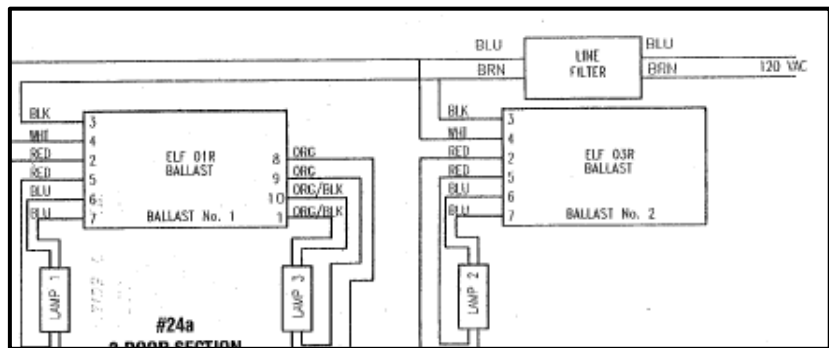
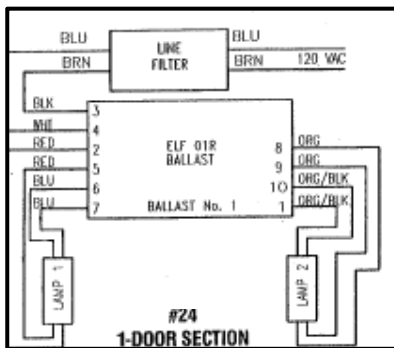

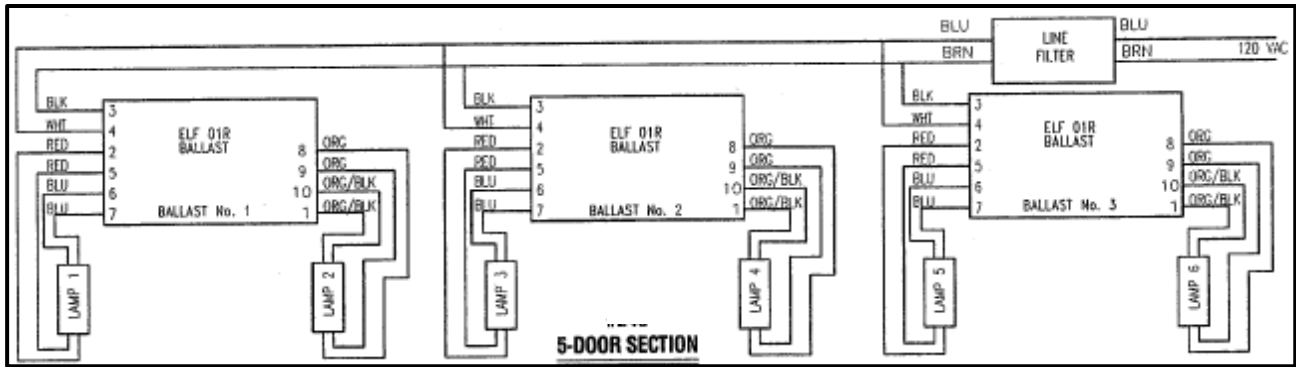

120V ELS Lighting System Component Layout

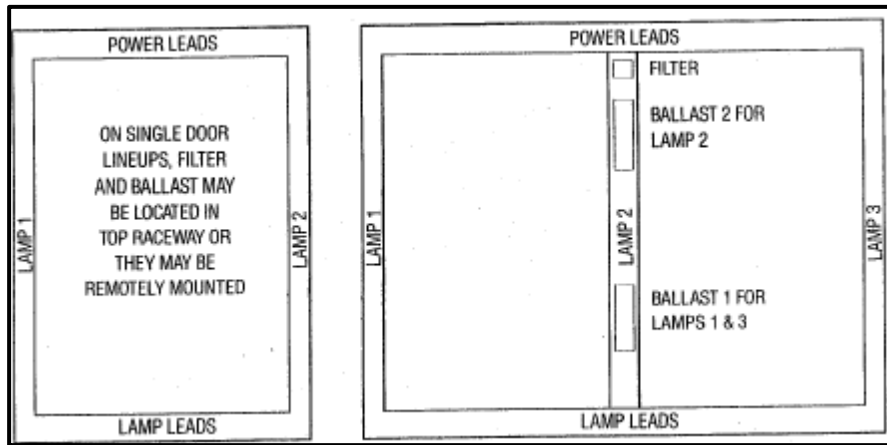

1-Door Section

2-Door Section

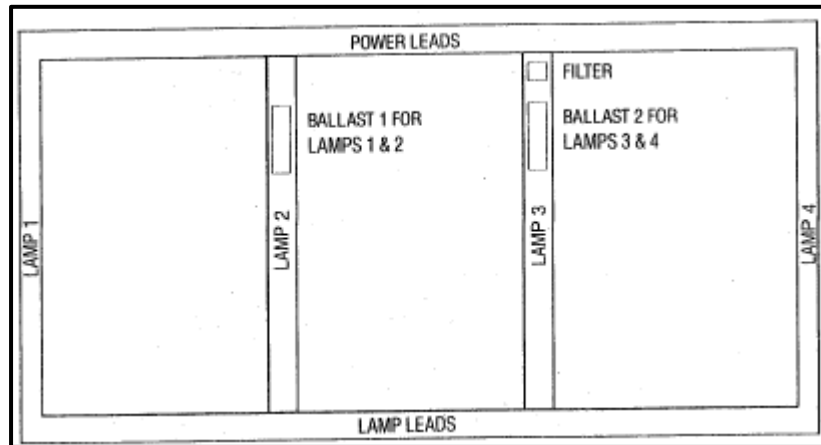

3-Door Section

Model 101/2100 Doors Service & Installation

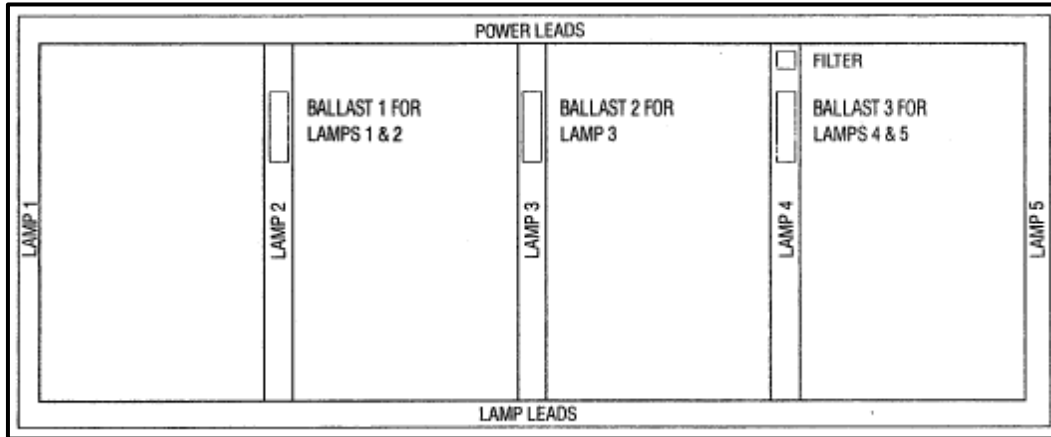

4-Door Section

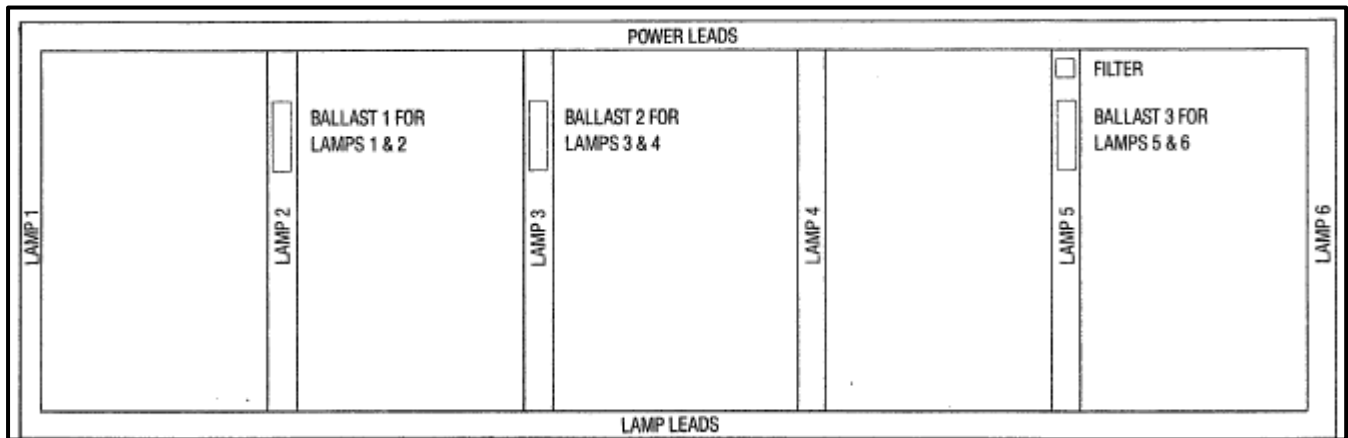

5-Door Section

220V Electronic Ballast Wiring Diagrams

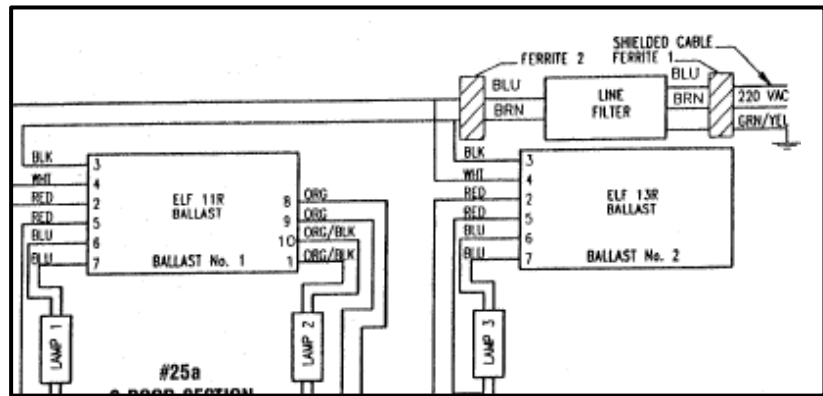
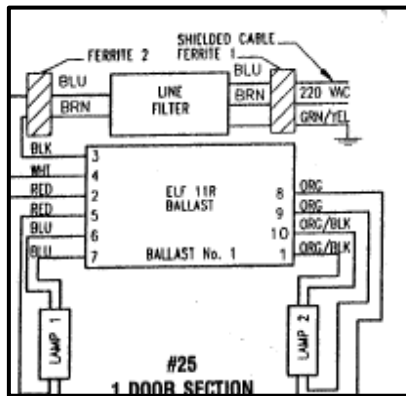

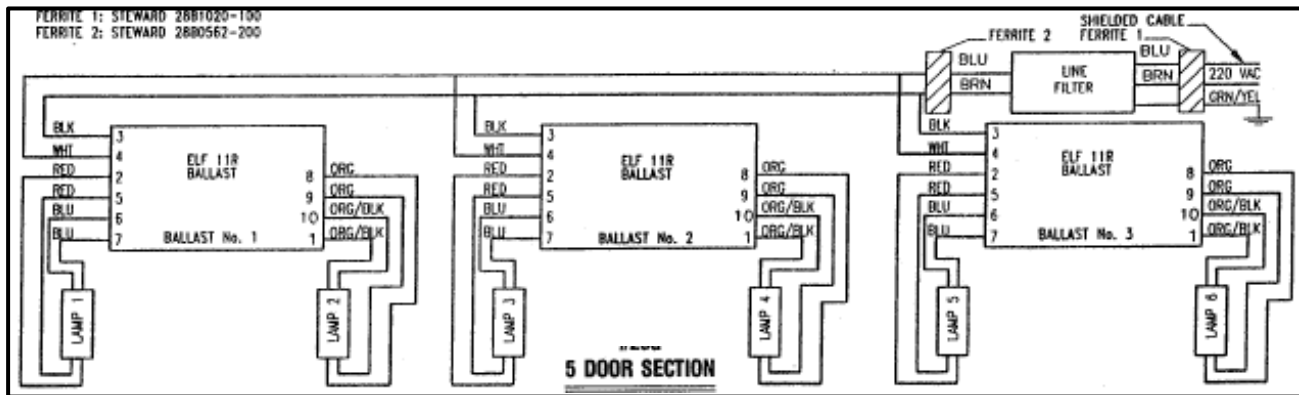
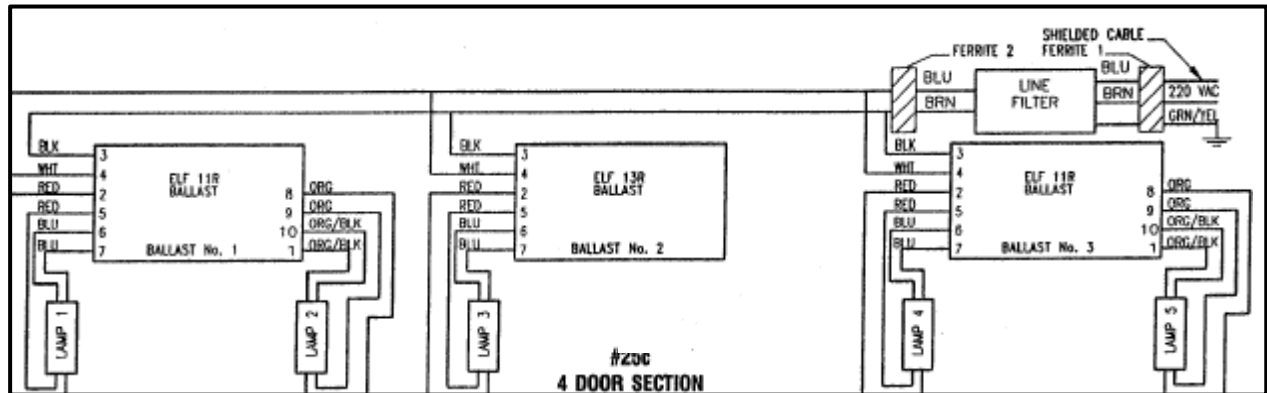
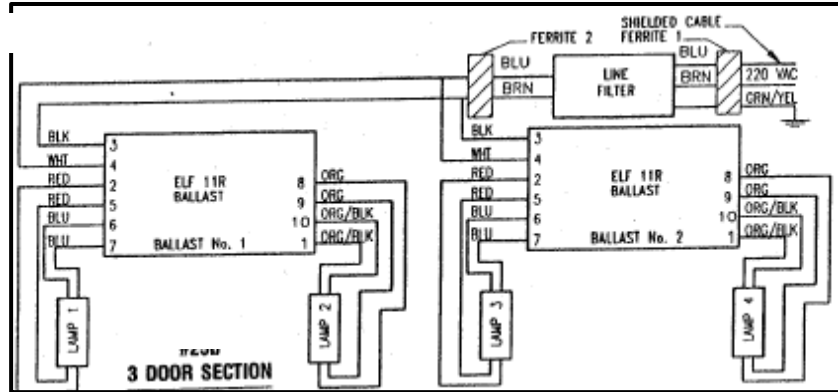

220V ELS Lighting System Component Layout

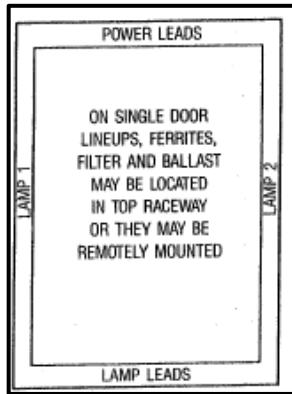

1-Door Section

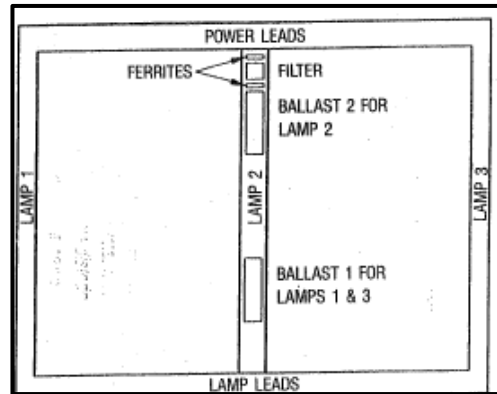

2-Door Section

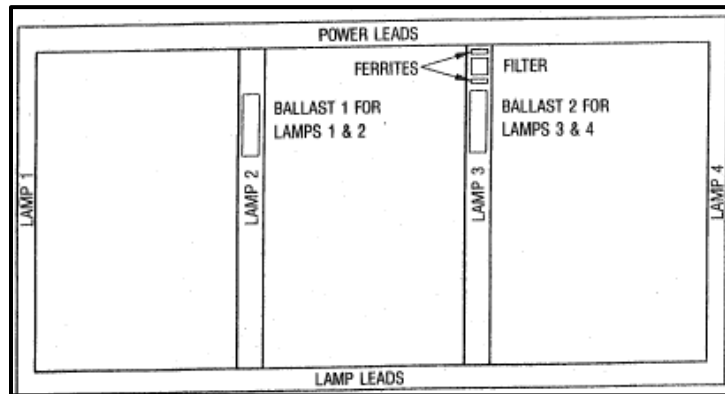

3-Door Section

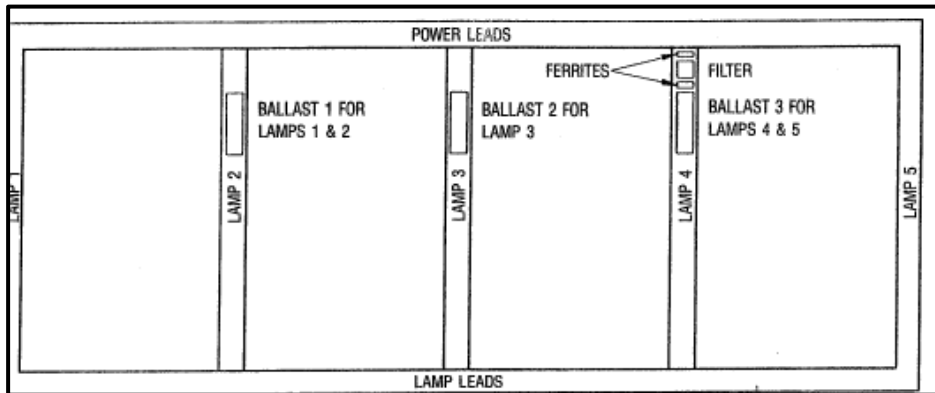

4-Door Section

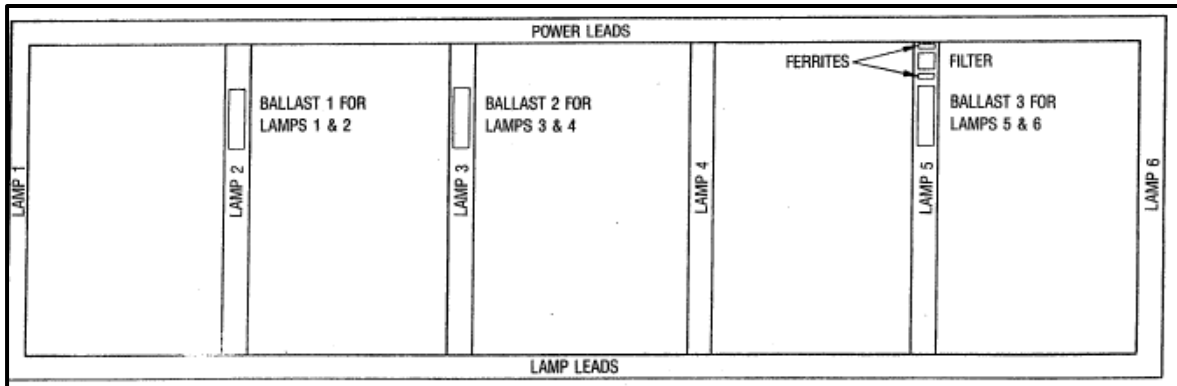

5-Door Section

66. T-8 Lamp Replacement Instructions

CENTER MULLION FIXTURES

1. Turn light power off before start of lamp replacement.
2. Remove top and bottom spring steel clips. Insert small flat-head screwdriver under clip to release clip from side of fixture (as shown in the following figure). On one side at a time, pull clip out of pre-punched holes in side of mullion.

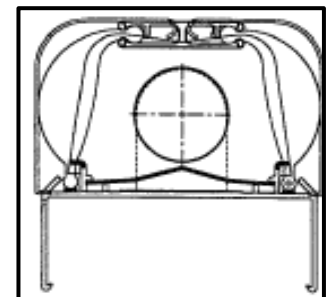
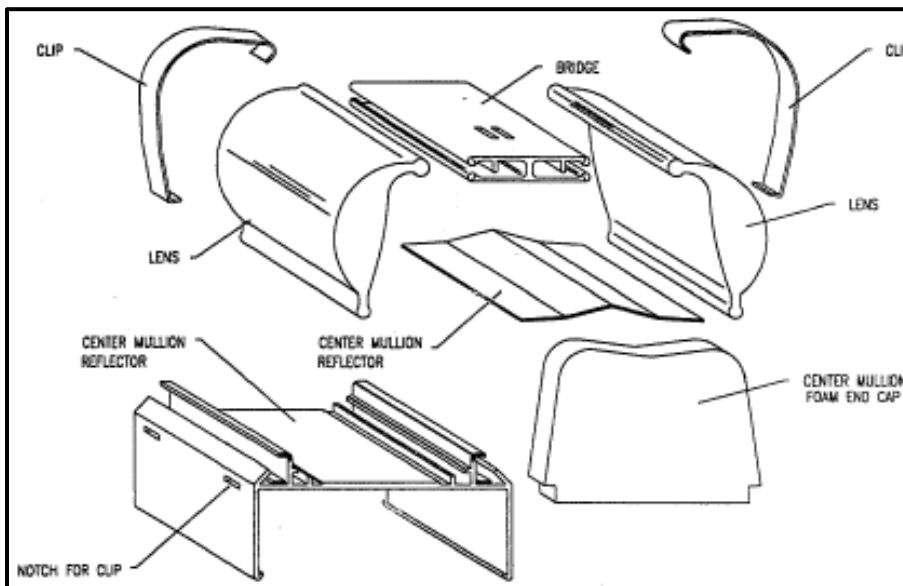
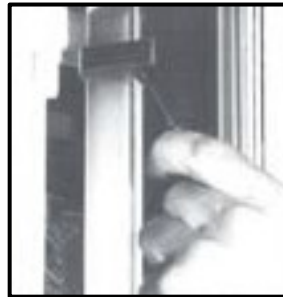

3. **Remove ELS lens.** Starting at top, pull lens away from front of light fixture that is attached to the frame mullion. If necessary, a small flat-head screwdriver can be inserted between the lens and black mullion plastic, to ease the lens out of the groove. **There is no need to remove the lens from the bridge** (the black or clear plastic piece connecting the two lenses at the back of the fixture).

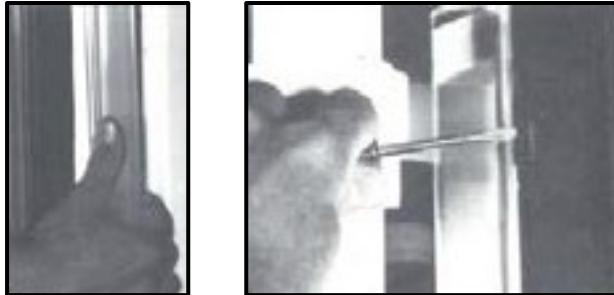

If pulled away from *one side* carefully, the lens will swing back into the case to give access to the bulb. Otherwise, the left and right lenses *and* the bridge will pull away from the fixture – in *one complete section*.



4. With the lens removed, hold lamp with fingers and twist bulb to line up with socket access holes.



Remove old bulb. *Remove insulator tubes from both ends of old bulb and replace on ends of new bulb.*

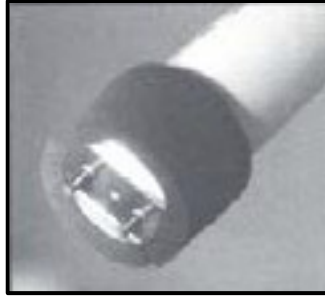

To **install new bulb**, place into socket and **turn two clicks**. There are foam end caps on the top and bottom of lamp sockets. **End caps must be attached before lens is replaced.**



5. Be sure that both ELS lenses are snapped securely into the plastic bridge before re-installing on the light fixture.

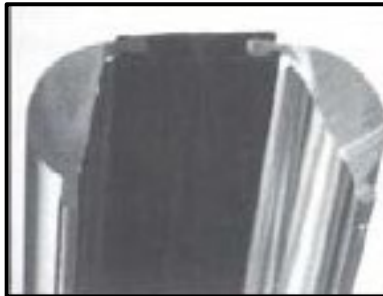

6. Install clip on plastic bridge, if required, before re-installing on light fixture.
7. Starting at the top on one side of the light fixture, line up the edge of the lens with the groove in the fixture plastic. **Snap lens into groove.** Repeat with lens on the other side, if removed.



- 8. Holding lens snugly against top of light fixture, install spring steel clip over lenses. Snap clip into pre-punched holes on each side of mullion. Move to bottom of fixture and install bottom clip.



IMPORTANT: Bulb insulators must be on each end of bulb before lenses are re-installed. **Foam end caps** should be securely attached to top and bottom of lamp sockets. *(Foam end caps are cut to fit snugly, but if they have become dislodged, or pulled out during changes, they **must be replaced!**)*

- 9. Turn light power on.

FRAME END FIXTURES

- 1. Turn light power off before start of lamp replacement.
- 2. **Remove top and bottom spring steel clips.** Insert small flat-head screwdriver under flat portion of spring steel clip to remove from side of fixture (as shown in the following figure). **Swing clips to the side until re-installation.**

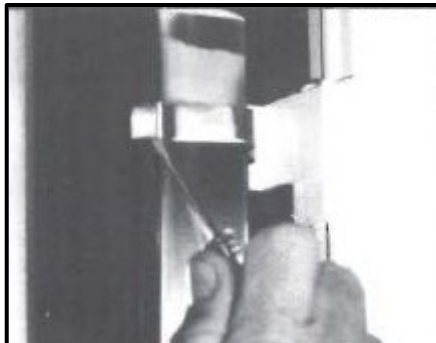

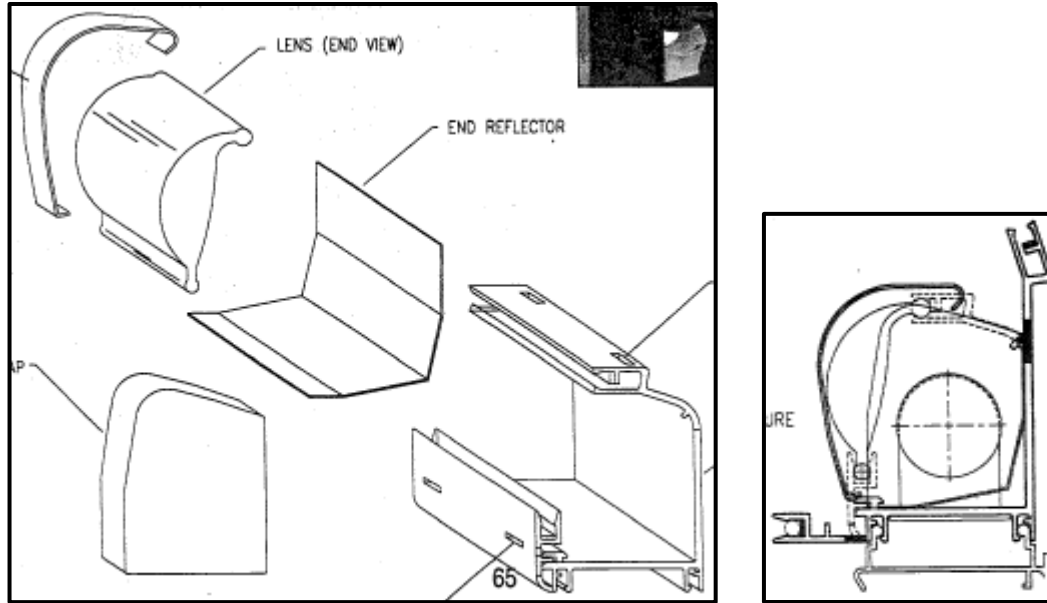

3. **Remove ELS lens.** Starting at top, pull lens away from inside front edge of fixture. If necessary, a small flat-head screwdriver can be inserted between the lens and black fixture plastic, to ease the lens out of the groove. If rear edge of lens is left in fixture plastic, lens will swing back on flexible “hinge” to expose bulb.



4. Reaching into fixture, hold bulb with fingers and twist to line up with socket access holes. **Remove old bulb.** *Remove insulator tubes from both ends of old bulb and replace on ends of new bulb.*

To **install new bulb**, place into socket and **turn two clicks**. There are foam end caps on the top and bottom of lamp sockets. **End caps must be attached before lens is replaced.**

5. Re-install ELS lens. If lens has been *completely* removed from fixture, pull grooved plastic rear section of fixture forward, and snap *rear edge* of ELS Lens back into the groove. (This part of the light fixture has a “hinge” or flexible portion, that swings away for easy bulb access. Install clip on hinging side, if required, before re-installing the other end of the lens. Starting at the top, snap the other side of the lens into the front groove of the lamp fixture.



6. End clips conform to the shape of the end fixture, and can be snapped into place only one way. The curved sides of the spring steel clip should be touching the lens. **Snap the top and bottom clips into place.**

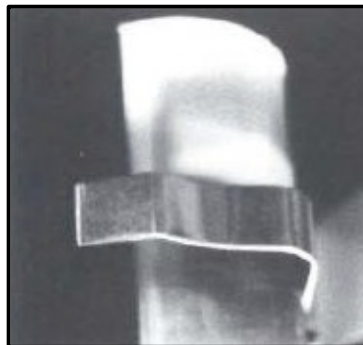

IMPORTANT: **Bulb insulators** must be on each end of bulb before lens is re-installed. **Foam end caps** should be securely attached to top and bottom of lamp sockets. (*Foam end caps are cut to fit snugly, but if they have become dislodged, or pulled out during changes, they **must be replaced!***)

7. Turn light power on.

67. Dew Point Chart

NORMAL TEMPERATURE APPLICATIONS

GLASS TYPE	ROOM TEMP (F)	CASE TEMPERATURE (F)				
		40	35	30	25	20
TWO PANE NHG*	70	70	66	61	58	53
	75	67	62	59	55	52
	80	63	60	57	53	50
	85	60	58	53	50	49
	90	58	55	52	49	47
THREE PANE NHG*	70	74	71	68	65	62
	75	72	68	66	63	60
	80	68	66	63	60	58
	85	66	64	61	58	56
	90	65	62	59	57	54
TWO PANE REFLECTIVE NHG*	70	76	75	70	67	63
	75	75	70	69	66	62
	80	70	68	66	62	59
	85	68	66	63	60	58
	90	67	64	60	58	56
TWO PANE HEATED GLASS	70	98	92	90	84	80
	75	95	90	86	84	77
	80	90	85	81	76	73
	85	86	80	78	72	69
	90	82	78	74	70	66

*NHG = Non Heated Glass

% REL HUMIDITY @ WHICH CONDENSATION FORMS ON GLASS

LOW TEMPERATURE APPLICATIONS

GLASS TYPE	ROOM TEMP (F)	CASE TEMPERATURE (F)					
		+5	0	-5	-10	-15	-20
THREE PANE HEATED REFLECTIVE GLASS	90	88	83	81	79	76	73
	85	81	80	78	76	72	70
	80	80	78	75	72	70	69
	79	78	77	73	71	68	68
	78	75	73	71	69	67	65

% REL HUMIDITY @ WHICH CONDENSATION FORMS ON GLASS

Calculations make no allowance for air leaks or unusual air flow patterns within cases and are intended to be used as guidelines only.

68. Electrical Information for Model 101 Low Temp Heated Doors, Frames & Standard Light Fixtures Heater Amperages @ 120 Volts

NUMBER OF DOORS:	1	2	3	4	5	6	7	8	9	10
STYLE: Low temp doors with heaters, 3-Pane Heated Reflective Glass (5.75 W/SQ. FT.)										
APPLICATION: Case Temperature -10°F, Humidity 75% or less, @ 75°F ambient.										
24 x 36	1.12	2.20	3.27	4.26	5.33	6.54	7.53	8.52	9.59	10.66
24 x 67	1.86	3.40	4.98	6.59	8.21	9.96	11.57	13.18	14.80	16.42
24 x 75	2.00	3.68	5.43	7.24	9.03	10.86	12.67	14.48	16.27	18.06
26 x 67	1.91	3.74	5.44	7.23	8.93	10.88	12.67	14.46	16.16	17.86
26 x 75	2.13	4.05	5.89	7.72	9.67	11.78	13.61	15.44	17.39	19.34
28 x 75	2.18	4.15	6.20	8.16	10.19	12.40	14.36	16.32	18.35	20.38
28 x 79	2.41	4.39	6.52	8.59	10.75	13.04	15.11	17.18	19.34	21.50
30 x 36	1.34	2.68	3.95	5.32	6.49	7.90	9.27	10.64	11.81	12.98
30 x 67	2.10	3.98	5.80	7.78	9.57	11.60	13.58	15.56	17.35	19.14
30 x 75	2.27	4.32	6.36	8.41	10.41	12.72	14.77	16.82	18.82	20.82
30 x 79	2.42	4.56	6.66	8.90	10.98	13.32	15.56	17.80	19.88	21.96

- NOTES:**
1. All amperages are design amperages subject to the following tolerances: heated glass +/- 8%.
 2. Although the amperages are calculated at 120 volts, all doors are designed to operate without sweating when used within the application parameters with a voltage range of +/- 10%.
 3. When calculating standard **lamp amperage**, add 1 lamp to the number of doors in the line-up and multiply that number by the appropriate AMPS PER LIGHT value.
 4. Design parameters do not make allowances for factors such as air leaks or unusual air flow patterns within cases; therefore, some sweating may occur when upper limits of temperature or humidity are encountered.

	11	12	13	14	15	16	17	18	19	20	AMPS PER LIGHT
24 x 36	11.79	12.78	13.93	14.92	15.99	17.04	18.11	19.26	20.25	21.32	NA
24 x 67	18.16	19.77	21.40	23.01	24.63	26.36	27.98	29.61	31.22	32.84	0.85
24 x 75	19.91	21.72	23.49	25.30	27.09	28.96	30.75	32.52	34.33	36.12	0.85
26 x 67	19.90	21.69	23.30	25.09	26.79	28.92	30.62	32.23	34.02	35.72	0.85
26 x 75	21.33	23.16	25.23	27.06	29.01	30.88	32.83	34.90	36.73	38.68	0.85
28 x 75	22.52	24.48	26.58	28.54	30.57	32.64	34.67	36.77	38.73	40.76	0.85
28 x 79	23.70	25.77	28.02	30.09	32.25	34.36	36.52	38.77	40.84	43.00	0.85
30 x 36	14.59	15.96	16.93	18.30	19.47	21.28	22.45	23.42	24.79	25.96	NA
30 x 67	21.36	23.34	24.94	26.92	28.71	31.12	32.91	34.51	36.49	38.28	0.85
30 x 75	23.18	25.23	27.18	29.23	31.23	33.64	35.64	37.59	39.64	41.64	0.85
30 x 79	24.46	26.70	28.62	30.86	32.94	35.60	37.68	39.60	41.84	43.92	0.85

**69. Electrical Information for Model 101 Normal Temp Heated Doors,
Frames & Standard Light Fixtures
Heater Amperages @ 120 Volts**

NUMBER OF DOORS:	1	2	3	4	5	6	7	8	9	10
STYLE: Normal temp doors with heaters, 2-Pane Non-Heated Glass										
APPLICATION: Case Temperature 38°F, Humidity 65% or less, @ 75°F ambient.										
24 x 36	0.27	0.55	0.82	1.09	1.36	1.64	1.91	2.18	2.45	2.72
24 x 67	0.43	0.86	1.30	1.73	2.16	2.60	3.03	3.46	3.89	4.32
24 x 75	0.46	0.92	1.39	1.85	2.31	2.78	3.24	3.70	4.16	4.62
26 x 67	0.44	0.87	1.31	1.74	2.18	2.62	3.05	3.48	3.92	4.36
26 x 75	0.47	0.93	1.40	1.87	2.34	2.80	3.27	3.74	4.21	4.68
28 x 75	0.50	0.99	1.49	1.99	2.48	2.98	3.48	3.98	4.47	4.96
28 x 79	0.49	0.97	1.46	1.95	2.43	2.92	3.41	3.90	4.38	4.86
30 x 36	0.31	0.62	0.92	1.23	1.54	1.84	2.15	2.46	2.77	3.08
30 x 67	0.47	0.94	1.40	1.87	2.34	2.80	3.27	3.74	4.21	4.68
30 x 75	0.49	0.98	1.47	1.96	2.45	2.94	3.43	3.92	4.41	4.90
30 x 79	0.53	1.05	1.58	2.10	2.63	3.16	3.68	4.20	4.73	5.26

NUMBER OF DOORS:	1	2	3	4	5	6	7	8	9	10
STYLE: Normal temp doors with heaters, 3-Pane Non-Heated Glass or 2-Pane Reflective NHG										
APPLICATION: Case Temperature 33°F, Humidity 68% or less, @ 75°F ambient.										
24 x 36	0.45	0.91	1.36	1.82	2.27	2.72	3.18	3.64	4.09	4.54
24 x 67	0.70	1.39	2.09	2.78	3.48	4.18	4.87	5.56	6.26	6.96
24 x 75	0.76	1.52	2.28	3.05	3.81	4.56	5.33	6.10	6.86	7.62
26 x 67	0.71	1.43	2.14	2.85	3.57	4.28	4.99	5.70	6.42	7.14
26 x 75	0.81	1.61	2.42	3.23	4.03	4.84	5.65	6.46	7.26	8.06
28 x 75	0.82	1.64	2.47	3.30	4.12	4.94	5.77	6.60	7.42	8.24
28 x 79	0.86	1.72	2.58	3.45	4.30	5.16	6.03	6.90	7.75	8.60
30 x 36	0.52	1.04	1.56	2.08	2.61	3.12	3.64	4.16	4.69	5.22
30 x 67	0.77	1.54	2.32	3.09	3.86	4.64	5.41	6.18	6.95	7.72
30 x 75	0.81	1.62	2.44	3.25	4.06	4.88	5.69	6.50	7.31	8.12
30 x 79	0.85	1.70	2.55	3.40	4.25	5.10	5.95	6.80	7.65	8.50

Model 101/2100 Doors Service & Installation

NUMBER OF DOORS:	1	2	3	4	5	6	7	8	9	10
STYLE: Normal temp doors with heaters, 2-Pane Heated Glass										
APPLICATION: Case Temperature 31°F, Humidity 80% or less, @ 75°F ambient.										
24 x 36	0.80	1.61	2.41	3.21	4.01	4.82	5.62	6.42	7.22	8.02
24 x 67	1.36	2.73	4.09	5.46	6.82	8.18	9.55	10.92	12.28	13.64
24 x 75	1.52	3.04	4.55	6.07	7.59	9.10	10.62	12.14	13.66	15.18
26 x 67	1.44	2.88	4.32	5.76	7.20	8.64	10.08	11.52	12.96	14.40
26 x 75	1.58	3.16	4.73	6.31	7.89	9.46	11.04	12.62	14.20	15.78
28 x 75	1.65	3.31	4.97	6.62	8.27	9.94	11.59	13.24	14.89	16.54
28 x 79	1.73	3.47	5.22	6.96	8.70	10.44	12.18	13.92	15.66	17.40
30 x 36	0.97	1.94	2.91	3.88	4.85	5.82	6.79	7.76	8.73	9.70
30 x 67	1.56	3.12	4.68	6.24	7.80	9.36	10.92	12.48	14.04	15.60
30 x 75	1.71	3.41	5.12	6.83	8.54	10.24	11.95	13.66	15.37	17.08
30 x 79	1.79	3.57	5.36	7.15	8.93	10.72	12.51	14.30	16.08	17.86

- NOTES:**
1. All amperages are design amperages subject to the following tolerances: non-heated glass +/- 5%, heated glass +/- 8%.
 2. Although the amperages are calculated at 120 volts, all doors are designed to operate without sweating when used within the application parameters with a voltage range of +/- 10%.

	11	12	13	14	15	16	17	18	19	20	AMPS PER LIGHT
24 x 36	3.00	3.27	3.54	3.81	4.08	4.36	4.63	4.90	5.17	5.44	0.46
24 x 67	4.76	5.19	5.62	6.05	6.48	6.92	7.35	7.78	8.21	8.64	0.55
24 x 75	5.09	5.55	6.01	6.47	6.93	7.40	7.86	8.32	8.78	9.24	0.55
26 x 67	4.79	5.22	5.66	6.10	6.54	6.96	7.40	7.84	8.28	8.72	0.55
26 x 75	5.14	5.61	6.08	6.55	7.02	7.48	7.95	8.42	8.89	9.36	0.55
28 x 75	5.74	5.97	6.45	6.95	7.44	7.96	8.45	8.93	9.43	9.92	0.55
28 x 79	5.36	5.85	6.32	6.81	7.29	7.80	8.28	8.75	9.24	9.72	0.55
30 x 36	3.38	3.69	4.00	4.31	4.62	4.92	5.23	5.54	5.85	6.16	0.46
30 x 67	5.14	5.61	6.08	6.55	7.02	7.48	7.95	8.42	8.89	9.36	0.55
30 x 75	5.39	5.88	6.37	6.86	7.35	7.84	8.33	8.82	9.31	9.80	0.55
30 x 79	5.78	6.30	6.840	7.36	7.89	8.40	8.93	9.47	9.99	10.52	0.55

	11	12	13	14	15	16	17	18	19	20	AMPS PER LIGHT
24 x 36	5.00	5.46	5.90	6.36	6.81	7.28	7.73	8.17	8.63	9.08	0.46
24 x 67	7.65	8.34	9.05	9.74	10.44	11.12	11.82	12.53	13.22	13.92	0.55
24 x 75	8.38	9.15	9.90	10.67	11.43	12.20	12.96	13.71	14.48	15.24	0.55
26 x 67	7.84	8.55	9.28	9.99	10.71	11.40	12.12	12.85	13.56	14.28	0.55
26 x 75	8.88	9.69	10.48	11.29	12.09	12.92	13.72	14.51	15.32	16.12	0.55
28 x 75	9.07	9.90	10.71	11.54	12.36	13.20	14.02	14.83	15.66	16.48	0.55
28 x 79	9.48	10.35	11.18	12.05	12.90	13.80	14.65	15.48	16.35	17.20	0.55
30 x 36	5.72	6.24	6.78	7.30	7.83	8.32	8.85	9.39	9.91	10.44	0.46
30 x 67	8.50	9.27	10.04	10.81	11.58	12.36	13.13	13.90	14.67	15.44	0.55
30 x 75	8.94	9.75	10.56	11.37	12.18	13.00	13.81	14.62	15.43	16.24	0.55
30 x 79	9.35	10.20	11.05	11.90	12.75	13.60	14.45	15.30	16.15	17.00	0.55

	11	12	13	14	15	16	17	18	19	20	AMPS PER LIGHT
24 x 36	8.83	9.63	10.43	11.23	12.03	12.84	13.64	14.44	15.24	16.04	0.46
24 x 67	15.01	16.38	17.74	19.10	20.46	21.84	23.20	24.56	25.92	27.28	0.55
24 x 75	16.69	18.21	19.73	21.25	22.77	24.28	25.80	27.32	28.84	30.36	0.55
26 x 67	15.84	17.28	18.72	20.16	21.60	23.04	24.48	25.92	27.36	28.80	0.55
26 x 75	17.35	18.93	20.51	22.09	23.67	25.24	26.82	28.40	29.98	31.56	0.55
28 x 75	18.21	19.86	21.51	23.16	24.81	26.48	28.13	29.78	31.43	33.08	0.55
28 x 79	19.14	20.88	22.62	24.36	26.10	27.84	29.58	31.32	33.06	34.80	0.55
30 x 36	10.67	11.64	12.61	13.58	14.55	15.52	16.49	17.46	18.43	19.40	0.46
30 x 67	17.16	18.72	20.28	21.84	23.40	24.96	26.52	28.08	29.64	31.20	0.55
30 x 75	18.78	20.49	22.20	23.91	25.62	27.32	29.03	30.74	32.45	34.16	0.55
30 x 79	19.66	21.45	23.22	25.01	26.79	28.60	30.38	32.15	33.94	35.72	0.55

- NOTES:**
- When calculating standard **lamp amperage**, add 1 lamp to the number of doors in the line-up and multiply that number by the appropriate AMPS PER LIGHT value.
 - Design parameters do not make allowances for factors such as air leaks or unusual air flow patterns within cases; therefore, some sweating may occur when upper limits of temperature or humidity are encountered.

70. Heat Load in BTU/Hr for Model 101 Low Temp Glass, Door Rail, Frame Heaters and Standard Lighting (Per Door, with Doors Closed @ 75°F Store Ambient)

MODEL 101 LOW TEMPERATURE					
(3-PANE HEATED REFLECTIVE GLASS – CASE TEMP -10°F)					
DOOR SIZE	1 DOOR	2 DOOR	3 DOOR	4 DOOR	5 DOOR
24 x 36	874	1448	2022	2596	3170
24 x 67	1061	1821	2582	3343	4104
24 x 75	1112	1924	2736	3548	4360
26 x 67	1094	1887	2681	3475	4268
26 x 75	1145	1990	2835	3680	4525
28 x 75	1182	2064	2946	3828	4710
28 x 79	1207	2113	3020	3927	4834
30 x 36	932	1564	2196	2828	3460
30 x 67	1155	2009	2864	3718	4573
30 x 75	1212	2124	3036	3948	4860
30 x 79	1241	2183	3124	4065	5006

NOTE: Add 10-20% to above values depending on door opening frequency.

71. Heat Load in BTU/Hr for Model 101 Normal Temp Glass, Door Rail, Frame Heaters and Standard Lighting (Per Door, with Doors Closed @ 75°F Store Ambient)

MODEL 101 NORMAL TEMPERATURE					
(2-PANE NON-HEATED GLASS – CASE TEMP 38°F)					
DOOR SIZE	1 DOOR	2 DOOR	3 DOOR	4 DOOR	5 DOOR
24 x 36	586	948	1309	1670	2031
24 x 67	692	1159	1627	2094	2561
24 x 75	720	1214	1709	2203	2698
26 x 67	709	1194	1678	2162	2646
26 x 75	739	1252	1766	2279	2793
28 x 75	758	1290	1823	2355	2888
28 x 79	773	1321	1869	2417	2965
30 x 36	615	1006	1396	1787	2177
30 x 67	743	1262	1780	2299	2817
30 x 75	777	1328	1880	2431	2983
30 x 79	793	1361	1929	2497	3065

MODEL 101 NORMAL TEMPERATURE					
(3-PANE NON-HEATED GLASS OR 2-PANE REFL. NHG – CASE TEMP 33°F)					
DOOR SIZE	1 DOOR	2 DOOR	3 DOOR	4 DOOR	5 DOOR
24 x 36	599	974	1348	1722	2097
24 x 67	708	1192	1675	2159	2642
24 x 75	737	1248	1760	2272	2783
26 x 67	725	1225	1724	2224	2724
26 x 75	755	1284	1814	2344	2873
28 x 75	773	1320	1868	2416	2964
28 x 79	789	1352	1916	2479	3043
30 x 36	628	1031	1435	1838	2241
30 x 67	757	1290	1822	2355	2887
30 x 75	791	1356	1922	2488	3054
30 x 79	807	1390	1972	2555	3137

MODEL 101 NORMAL TEMPERATURE					
(2-PANE HEATED GLASS – CASE TEMP 31°F)					
DOOR SIZE	1 DOOR	2 DOOR	3 DOOR	4 DOOR	5 DOOR
24 x 36	665	1106	1546	1987	2427
24 x 67	825	1426	2026	2627	3227
24 x 75	867	1509	2150	2792	3434
26 x 67	850	1475	2100	2724	3349
26 x 75	894	1563	2231	2900	3569
28 x 75	921	1617	2312	3008	3704
28 x 79	944	1663	2382	3101	3820
30 x 36	708	1191	1675	2158	2641
30 x 67	899	1572	2246	2919	3593
30 x 75	948	1671	2393	3116	3839
30 x 79	972	1720	2467	3214	3962

NOTE: Add 10-20% to above values depending on door opening frequency.

**72. Heat Load in BTU/Hr for Model 2100 Low Temp Glass, Door Rail,
Frame Heaters and Standard Lighting
(Per Door, with Doors Closed @ 75°F Store Ambient)**

MODEL 2100 LOW TEMPERATURE					
(3-PANE HEATED REFLECTIVE GLASS – CASE TEMP -10°F)					
DOOR SIZE	1 DOOR	2 DOOR	3 DOOR	4 DOOR	5 DOOR
24 x 36	884	1468	1052	2636	3219
24 x 67	1079	1859	2638	3417	4196
24 x 75	1133	1966	2798	3631	4464
26 x 67	1114	1928	2741	3555	4369
26 x 75	1167	2035	2902	3770	4637
28 x 75	1206	2113	3019	3925	4832
28 x 79	1232	2164	3097	4029	4961
30 x 36	944	1589	2233	2877	3522
30 x 67	1178	2055	2933	3811	4688
30 x 75	1238	2176	3114	4052	4990
30 x 79	1269	2237	3206	4174	5143

NOTE: Add 10-20% to above values depending on door opening frequency.

73. Electrical Information for Model 2100 Low Temp Heated Doors, Frames & Standard Light Fixtures Heater Amperages @ 120 Volts

NUMBER OF DOORS:	1	2	3	4	5	6	7	8	9	10
STYLE: Low temp doors with heaters, 3-Pane Heated Reflective Glass (5.75 W/SQ. FT.)										
APPLICATION: Case Temperature -10°F, Humidity 74% or less, @ 75°F ambient.										
24 x 36	1.11	2.19	3.24	4.23	5.29	6.48	7.47	8.46	9.52	10.58
24 x 67	1.84	3.37	4.94	6.54	8.14	9.88	11.48	13.08	14.68	16.28
24 x 75	1.98	3.65	5.38	7.18	8.95	10.76	12.56	14.36	16.13	17.90
26 x 67	1.97	3.71	5.40	7.17	8.86	10.80	12.57	14.34	16.03	17.72
26 x 75	2.12	3.97	5.77	7.58	9.38	11.54	13.35	15.16	16.96	18.76
28 x 75	2.16	4.11	6.15	8.08	10.06	12.30	14.23	16.16	18.14	20.12
28 x 79	2.33	4.23	6.28	8.28	10.30	12.56	14.56	16.56	18.58	20.60
30 x 36	1.30	2.60	3.82	5.15	6.28	7.64	8.97	10.30	11.43	12.56
30 x 67	2.07	3.91	5.69	7.63	9.39	11.38	13.32	15.26	17.02	18.78
30 x 75	2.23	4.23	6.23	8.24	10.19	12.46	14.47	16.48	18.43	20.38
30 x 79	2.37	4.46	6.51	8.70	10.74	13.02	15.21	17.40	19.44	21.48

- NOTES:**
1. All amperages are design amperages subject to the following tolerances: heated glass +/- 8%.
 2. Although the amperages are calculated at 120 volts, all doors are designed to operate without sweating when used within the application parameters with a voltage range of +/- 10%.
 3. When calculating standard **lamp amperage**, add 1 lamp to the number of doors in the line-up and multiply that number by the appropriate AMPS PER LIGHT value.
 4. Design parameters do not make allowances for factors such as air leaks or unusual air flow patterns within cases; therefore, some sweating may occur when upper limits of temperature or humidity are encountered.

	11	12	13	14	15	16	17	18	19	20	AMPS PER LIGHT
24 x 36	11.70	12.69	13.82	14.81	15.87	16.92	17.98	19.11	20.10	21.16	NA
24 x 67	18.02	19.62	21.22	22.82	24.42	26.16	27.76	29.36	30.96	32.56	0.85
24 x 75	19.74	21.54	23.28	25.08	26.85	28.72	30.49	32.23	34.03	35.80	0.85
26 x 67	19.74	21.51	23.12	24.89	26.58	28.68	30.37	31.98	33.75	35.44	0.85
26 x 75	20.93	22.74	24.53	26.34	28.14	30.32	32.12	33.91	35.72	37.52	0.85
28 x 75	22.31	24.24	26.27	28.20	30.18	32.32	34.30	36.33	38.26	40.24	0.85
28 x 79	22.84	24.84	26.88	28.88	30.90	33.12	35.14	37.18	39.18	41.20	0.85
30 x 36	14.12	15.45	16.38	17.71	18.84	20.60	21.73	22.66	23.99	25.12	NA
30 x 67	20.95	22.89	24.47	26.41	28.17	30.52	32.28	33.86	35.80	37.56	0.85
30 x 75	22.71	24.72	26.61	28.62	30.57	32.96	34.91	36.80	38.81	40.76	0.85
30 x 79	23.91	26.10	27.99	30.18	32.22	34.80	36.84	38.73	40.92	42.96	0.85

74. Electrical Information for Model 2100 Normal Temp Doors, Frames & Standard Light Fixtures Heater Amperages @ 120 Volts

NUMBER OF DOORS:	1	2	3	4	5	6	7	8	9	10
STYLE: Normal temp doors without heaters, 3-Pane Non-Heated Glass										
APPLICATION: Case Temperature 38°F, Humidity 70% @ 75°F ambient.										
24 x 36	0.27	0.54	0.81	1.08	1.35	1.62	1.89	2.16	2.43	2.70
24 x 67	0.42	0.84	1.26	1.68	2.10	2.52	2.94	3.36	3.78	4.20
24 x 75	0.46	0.92	1.37	1.83	2.29	2.74	3.20	3.66	4.12	4.58
26 x 67	0.43	0.86	1.28	1.71	2.14	2.56	2.99	3.42	3.85	4.28
26 x 75	0.47	0.95	1.42	1.89	2.37	2.84	3.31	3.78	4.26	4.74
28 x 75	0.50	0.99	1.49	1.99	2.48	2.98	3.48	3.98	4.47	4.96
28 x 79	0.52	1.03	1.55	2.06	2.58	3.10	3.61	4.12	4.64	5.16
30 x 36	0.31	0.62	0.94	1.25	1.56	1.88	2.19	2.50	2.81	3.13
30 x 67	0.46	0.93	1.39	1.86	2.32	2.78	3.25	3.72	4.18	4.64
30 x 75	0.49	0.98	1.47	1.96	2.45	2.94	3.43	3.92	4.41	4.90
30 x 79	0.51	1.02	1.52	2.03	2.54	3.04	3.55	4.06	4.57	5.08

NUMBER OF DOORS:	1	2	3	4	5	6	7	8	9	10
STYLE: Normal temp doors without heaters, 3-Pane Non-Heated Glass (Low Energy Product)										
APPLICATION: Case Temperature 38°F, Humidity 65% @ 75°F ambient.										
24 x 36	0.17	0.33	0.52	0.69	0.87	1.04	1.21	1.38	1.56	1.74
24 x 67	0.27	0.53	0.80	1.06	1.33	1.60	1.86	2.12	2.39	2.66
24 x 75	0.29	0.59	0.88	1.17	1.47	1.76	2.05	2.34	2.64	2.94
26 x 67	0.28	0.55	0.83	1.10	1.38	1.66	1.93	2.20	2.48	2.76
26 x 75	0.28	0.57	0.85	1.14	1.42	1.70	1.99	2.28	2.56	2.84
30 x 36	0.20	0.38	0.60	0.79	0.99	1.20	1.39	1.58	1.78	1.99
30 x 67	0.30	0.59	0.89	1.19	1.49	1.78	2.08	2.38	2.68	2.97
30 x 75	0.31	0.62	0.94	1.25	1.56	1.88	2.19	2.50	2.81	3.13

- NOTES:**
1. All amperages are design amperages subject to the following tolerances: non-heated glass +/- 5%.
 2. Although the amperages are calculated at 120 volts, all doors are designed to operate without sweating when used within the application parameters with a voltage range of +/- 10%.
 3. When calculating standard **lamp amperage**, add 1 lamp to the number of doors in the line-up and multiply that number by the appropriate AMPS PER LIGHT value.
 4. Design parameters do not make allowances for factors such as air leaks or unusual air flow patterns within cases; therefore, some sweating may occur when upper limits of temperature or humidity are encountered.

	11	12	13	14	15	16	17	18	19	20	AMPS PER LIGHT
24 x 36	2.97	3.24	3.51	3.78	4.05	4.32	4.59	4.86	5.13	5.40	0.46
24 x 67	4.62	5.04	5.46	5.88	6.30	6.72	7.14	7.56	7.98	8.40	0.55
24 x 75	5.03	5.49	5.95	6.41	6.87	7.32	7.78	8.24	8.70	9.16	0.55
26 x 67	4.70	5.13	5.56	5.99	6.42	6.84	7.27	7.70	8.13	8.56	0.55
26 x 75	5.20	5.67	6.15	6.63	7.11	7.56	8.04	8.52	9.00	9.48	0.55
28 x 75	5.47	5.97	6.45	6.95	7.44	7.96	8.45	8.93	9.43	9.92	0.55
28 x 79	5.67	6.18	6.71	7.22	7.74	8.24	8.76	9.29	9.80	10.32	0.55
30 x 36	3.44	3.75	4.06	4.37	4.69	5.00	5.31	5.62	5.93	6.25	0.46
30 x 67	5.11	5.58	6.04	6.50	6.97	7.44	7.90	8.36	8.82	9.30	0.55
30 x 75	5.39	5.88	6.37	6.86	7.35	7.84	8.33	8.82	9.31	9.80	0.55
30 x 79	5.58	6.09	6.60	7.11	7.62	8.12	8.63	9.14	9.65	10.16	0.55

	11	12	13	14	15	16	17	18	19	20	AMPS PER LIGHT
24 x 36	1.90	2.07	2.25	2.43	2.61	2.76	2.94	3.12	3.30	3.48	0.46
24 x 67	2.92	3.18	3.45	3.72	3.99	4.24	4.51	4.78	5.05	5.32	0.55
24 x 75	3.22	3.51	3.81	4.11	4.41	4.68	4.98	5.28	5.58	5.88	0.55
26 x 67	3.03	3.30	3.58	3.86	4.14	4.40	4.68	4.96	5.24	5.52	0.55
26 x 75	3.13	3.42	3.70	3.98	4.26	4.56	4.84	5.12	5.40	5.68	0.55
30 x 36	2.18	2.37	2.57	2.77	2.97	3.16	3.36	3.56	3.76	3.95	0.46
30 x 67	3.27	3.57	3.87	4.17	4.46	4.76	5.06	5.36	5.66	5.95	0.55
30 x 75	3.44	3.75	4.06	4.37	4.69	5.00	5.31	5.62	5.93	6.25	0.55

**75. Heat Load in BTU/Hr for Model 2100 Normal Temp Glass, Door Rail, Frame Heaters and Standard Lights
(Per Door, with Doors Closed @ 75°F Store Ambient)**

MODEL 2100 NORMAL TEMPERATURE					
(3-PANE NON-HEATED GLASS – CASE TEMP 38°F) – STANDARD PRODUCT					
DOOR SIZE	1 DOOR	2 DOOR	3 DOOR	4 DOOR	5 DOOR
24 x 36	557	888	1220	1551	1883
24 x 67	637	1049	1460	1872	2284
24 x 75	658	1090	1523	1955	2388
26 x 67	649	1074	1498	1922	2347
26 x 75	671	1118	1564	2011	2457
28 x 75	685	1145	1606	2066	2526
28 x 79	697	1169	1641	2113	2585
30 x 36	578	931	1285	1638	1991
30 x 67	674	1123	1573	2022	2471
30 x 75	699	1173	1647	2121	2595
30 x 79	711	1198	1684	2171	2657

MODEL 2100 NORMAL TEMPERATURE					
(3-PANE NON-HEATED GLASS – CASE TEMP 38°F) – LOW ENERGY PRODUCT					
DOOR SIZE	1 DOOR	2 DOOR	3 DOOR	4 DOOR	5 DOOR
24 x 36	544	862	1181	1500	1819
24 x 67	617	1010	1402	1795	2187
24 x 75	636	1048	1459	1871	2282
26 x 67	629	1034	1438	1843	2247
26 x 75	650	1075	1499	1924	2349
30 x 36	564	903	1242	1581	1921
30 x 67	654	1082	1511	1939	2368
30 x 75	677	1128	1580	2032	2483

NOTE: Add 10-20% to above values depending on door opening frequency.

76. Heat Load in BTU/Hr for Model 101 Low Temp Glass, Door Rail, Frame Heaters and “ELS” Electronic Lighting System (Per Door, with Doors Closed @ 75°F Store Ambient)

MODEL 101 “ELS” LOW TEMPERATURE					
(3-PANE HEATED REFLECTIVE GLASS – CASE TEMP -10°F)					
DOOR SIZE	1 DOOR	2 DOOR	3 DOOR	4 DOOR	5 DOOR
24 x 36	487	867	1248	1628	2009
24 x 67	762	1373	1984	2595	3206
24 x 75	795	1532	2213	2894	3575
26 x 67	886	1439	2083	2727	3371
26 x 75	886	1601	2317	3032	3748
28 x 75	923	1675	2428	3181	3933
28 x 79	948	1725	2502	3279	4056
30 x 36	545	983	1422	1860	2299
30 x 67	855	1560	2265	2970	3675
30 x 75	953	1735	2518	3300	4083
30 x 79	982	1794	2605	3417	4229

NOTE: Add 10-20% to above values depending on door opening frequency.

77. Electrical Information for Model 101 Low Temp Doors, Frames & “ELS Electronic Lighting System Heater Amperages @ 120 Volts

NUMBER OF DOORS:	1	2	3	4	5	6	7	8	9	10
STYLE: Low temp doors with heaters, 3-Pane Heated Reflective Glass (5.75 W/SQ. FT.)										
APPLICATION: Case Temperature -10°F, Humidity 75% or less @ 75°F ambient.										
24 x 36	1.12	2.20	3.27	4.26	5.33	6.54	7.53	8.52	9.59	10.66
24 x 67	1.86	3.40	4.98	6.59	8.21	9.96	11.57	13.18	14.80	16.42
24 x 75	2.00	3.68	5.43	7.24	9.03	10.86	12.67	14.48	16.27	18.06
26 x 67	1.91	3.74	5.44	7.23	8.93	10.88	12.67	14.46	16.16	17.86
26 x 75	2.13	4.05	5.89	7.72	9.67	11.78	13.61	15.44	17.39	19.34
28 x 75	2.18	4.15	6.20	8.16	10.19	12.40	14.36	16.32	18.35	20.38
28 x 79	2.41	4.39	6.52	8.59	10.75	13.04	15.11	17.18	19.34	21.50
30 x 36	1.34	2.68	3.95	5.32	6.49	7.90	9.27	10.64	11.81	12.98
30 x 67	2.10	3.98	5.80	7.78	9.57	11.60	13.58	15.56	17.35	19.14
30 x 75	2.29	4.32	6.36	8.41	10.41	12.72	14.77	16.82	18.82	20.80
30 x 79	2.42	4.56	6.66	8.90	10.98	13.32	15.56	17.80	19.88	21.96

- NOTES:**
1. All amperages are design amperages subject to the following tolerances: heated glass +/- 8%.
 2. Although the amperages are calculated at 120 volts, all doors are designed to operate without sweating when used within the application parameters with a voltage range of +/- 10%.
 3. Design parameters do not make allowances for factors such as air leaks or unusual air flow patterns within cases; therefore, some sweating may occur when upper limits of temperature or humidity are encountered.
 4. See following chart for calculating additional **Light Amperage** for “ELS” Electronic Lighting:

“ELS” Lighting System 120 Volt Light Amperage (per frame section)					
No. Doors:	1	2	3	4	5
No. “ELS” Lights:	2	3	4	5	6
LAMPS LENGTH	TOTAL AMPS				
48”	0.92	1.45	1.84	2.37	2.76
60”	1.30	2.02	2.60	3.32	3.90
72”	1.31	2.07	2.62	3.38	3.93

Model 101/2100 Doors Service & Installation

	11	12	13	14	15	16	17	18	19	20
24 x 36	11.79	12.78	13.93	14.92	15.99	17.04	18.11	19.26	20.25	21.32
24 x 67	18.16	19.77	21.40	23.01	24.63	26.36	27.98	29.61	31.22	32.84
24 x 75	19.91	21.72	23.49	25.30	27.09	28.96	30.75	32.52	34.33	36.12
26 x 67	19.90	21.69	23.30	25.09	26.79	28.92	30.62	32.23	34.02	35.72
26 x 75	21.33	23.16	25.23	27.06	29.01	30.88	32.83	34.90	36.73	38.68
28 x 75	22.52	24.48	26.58	28.54	30.57	32.64	34.67	36.77	38.73	40.76
28 x 79	23.70	25.77	28.02	30.09	32.25	34.36	36.52	38.77	40.84	43.00
30 x 36	14.59	15.96	16.93	18.30	19.47	21.28	22.45	23.42	24.79	25.96
30 x 67	21.36	23.34	24.94	26.92	28.71	31.12	32.91	34.51	36.49	38.28
30 x 75	23.18	25.23	27.18	29.23	31.23	33.64	35.64	37.59	39.64	41.64
30 x 79	24.46	26.70	28.62	30.86	32.94	35.60	37.68	39.60	41.84	43.92

78. Electrical Information for Model 101 Normal Temp Doors, Frames & "ELS" Electronic Lighting System Heater Amperages @ 120 Volts

NUMBER OF DOORS:	1	2	3	4	5	6	7	8	9	10
STYLE: Normal temp doors with heaters, 2-Pane Non-Heated Glass										
APPLICATION: Case Temperature 38°F, Humidity 65% or less, @ 75°F ambient.										
24 x 36	0.27	0.55	0.82	1.09	1.36	1.64	1.91	2.18	2.45	2.72
24 x 67	0.43	0.86	1.30	1.73	2.16	2.60	3.03	3.46	3.89	4.32
24 x 75	0.46	0.92	1.39	1.85	2.31	2.78	3.24	3.70	4.16	4.62
26 x 67	0.44	0.87	1.31	1.74	2.18	2.62	3.05	3.48	3.92	4.36
26 x 75	0.47	0.93	1.40	1.87	2.34	2.80	3.27	3.74	4.21	4.68
28 x 75	0.50	0.99	1.49	1.99	2.48	2.98	3.48	3.98	4.47	4.96
28 x 79	0.49	0.97	1.46	1.95	2.43	2.92	3.41	3.90	4.38	4.86
30 x 36	0.31	0.62	0.92	1.23	1.54	1.84	2.15	2.46	2.77	3.08
30 x 67	0.47	0.94	1.40	1.87	2.34	2.80	3.27	3.74	4.21	4.68
30 x 75	0.49	0.98	1.47	1.96	2.45	2.94	3.43	3.92	4.41	4.90
30 x 79	0.53	1.05	1.58	2.10	2.63	3.16	3.68	4.20	4.73	5.26

NUMBER OF DOORS:	1	2	3	4	5	6	7	8	9	10
STYLE: Normal temp doors with heaters, 3-Pane Non-Heated Glass or 2-Pane Reflective NHG										
APPLICATION: Case Temperature 33°F, Humidity 68% or less, @ 75°F ambient.										
24 x 36	0.45	0.91	1.36	1.82	2.27	2.72	3.18	3.64	4.09	4.54
24 x 67	0.70	1.39	2.09	2.78	3.48	4.18	4.87	5.56	6.26	6.96
24 x 75	0.76	1.52	2.28	3.05	3.81	4.56	5.33	6.10	6.86	7.62
26 x 67	0.71	1.43	2.14	2.85	3.57	4.28	4.99	5.70	6.42	7.14
26 x 75	0.81	1.61	2.42	3.23	4.03	4.84	5.65	6.46	7.26	8.06
28 x 75	0.82	1.64	2.47	3.30	4.12	4.94	5.77	6.60	7.42	8.24
28 x 79	0.86	1.72	2.58	3.45	4.30	5.16	6.03	6.90	7.75	8.60
30 x 36	0.52	1.04	1.56	2.08	2.61	3.12	3.64	4.16	4.69	5.22
30 x 67	0.77	1.54	2.32	3.09	3.86	4.64	5.41	6.18	6.95	7.72
30 x 75	0.81	1.62	2.44	3.25	4.06	4.88	5.69	6.50	7.31	8.12
30 x 79	0.85	1.70	2.55	3.40	4.25	5.10	5.95	6.80	7.65	8.50

NUMBER OF DOORS:	1	2	3	4	5	6	7	8	9	10
STYLE: Normal temp doors with heaters, 2-Pane Heated Glass										
APPLICATION: Case Temperature 31°F, Humidity 80% or less, @ 75°F ambient.										
24 x 36	0.80	1.61	2.41	3.21	4.01	4.82	5.62	6.42	7.22	8.02
24 x 67	1.36	2.73	4.09	5.46	6.82	8.18	9.55	10.92	12.28	13.64
24 x 75	1.52	3.04	4.55	6.07	7.59	9.10	10.62	12.14	13.66	15.18
26 x 67	1.44	2.88	4.32	5.76	7.20	8.64	10.08	11.52	12.96	14.40
26 x 75	1.58	3.16	4.73	6.31	7.89	9.46	11.04	12.62	14.20	15.78
28 x 75	1.65	3.31	4.97	6.62	8.27	9.94	11.59	13.24	14.89	16.54
28 x 79	1.73	3.47	5.22	6.96	8.70	10.44	12.18	13.92	15.66	17.40
30 x 36	0.97	1.94	2.91	3.88	4.85	5.82	6.79	7.76	8.73	9.70
30 x 67	1.56	3.12	4.68	6.24	7.80	9.36	10.92	12.48	14.04	15.60
30 x 75	1.71	3.41	5.12	6.83	8.54	10.24	11.95	13.66	15.37	17.08
30 x 79	1.79	3.57	5.36	7.15	8.93	10.72	12.51	14.30	16.08	17.86

- NOTES:**
1. All amperages are design amperages subject to the following tolerances: non-heated glass +/- 5%, heated glass +/- 8%.
 2. Although the amperages are calculated at 120 volts, all doors are designed to operate without sweating when used within the application parameters with a voltage range of +/- 10%.
 3. Design parameters do not make allowances for factors such as air leaks or unusual air flow patterns within cases; therefore, some sweating may occur when upper limits of temperature or humidity are encountered.

Model 101/2100 Doors Service & Installation

	11	12	13	14	15	16	17	18	19	20
24 x 36	3.00	3.27	3.54	3.81	4.08	4.36	4.63	4.90	5.17	5.44
24 x 67	4.76	5.19	5.62	6.05	6.48	6.92	7.35	7.78	8.21	8.64
24 x 75	5.09	5.55	6.01	6.47	6.93	7.40	7.86	8.32	8.78	9.24
26 x 67	4.79	5.22	5.66	6.10	6.54	6.96	7.40	7.84	8.28	8.72
26 x 75	5.14	5.61	6.08	6.55	7.02	7.48	7.95	8.42	8.89	9.36
28 x 75	5.74	5.97	6.45	6.95	7.44	7.96	8.45	8.93	9.43	9.92
28 x 79	5.36	5.85	6.32	6.81	7.29	7.80	8.28	8.75	9.24	9.72
30 x 36	3.38	3.69	4.00	4.31	4.62	4.92	5.23	5.54	5.85	6.16
30 x 67	5.14	5.61	6.08	6.55	7.02	7.48	7.95	8.42	8.89	9.36
30 x 75	5.39	5.88	6.37	6.86	7.35	7.84	8.33	8.82	9.31	9.80
30 x 79	5.78	6.30	6.840	7.36	7.89	8.40	8.93	9.47	9.99	10.52

	11	12	13	14	15	16	17	18	19	20
24 x 36	5.00	5.46	5.90	6.36	6.81	7.28	7.73	8.17	8.63	9.08
24 x 67	7.65	8.34	9.05	9.74	10.44	11.12	11.82	12.53	13.22	13.92
24 x 75	8.38	9.15	9.90	10.67	11.43	12.20	12.96	13.71	14.48	15.24
26 x 67	7.84	8.55	9.28	9.99	10.71	11.40	12.12	12.85	13.56	14.28
26 x 75	8.88	9.69	10.48	11.29	12.09	12.92	13.72	14.51	15.32	16.12
28 x 75	9.07	9.90	10.71	11.54	12.36	13.20	14.02	14.83	15.66	16.48
28 x 79	9.48	10.35	11.18	12.05	12.90	13.80	14.65	15.48	16.35	17.20
30 x 36	5.72	6.24	6.78	7.30	7.83	8.32	8.85	9.39	9.91	10.44
30 x 67	8.50	9.27	10.04	10.81	11.58	12.36	13.13	13.90	14.67	15.44
30 x 75	8.94	9.75	10.56	11.37	12.18	13.00	13.81	14.62	15.43	16.24
30 x 79	9.35	10.20	11.05	11.90	12.75	13.60	14.45	15.30	16.15	17.00

	11	12	13	14	15	16	17	18	19	20
24 x 36	8.83	9.63	10.43	11.23	12.03	12.84	13.64	14.44	15.24	16.04
24 x 67	15.01	16.38	17.74	19.10	20.46	21.84	23.20	24.56	25.92	27.28
24 x 75	16.69	18.21	19.73	21.25	22.77	24.28	25.80	27.32	28.84	30.36
26 x 67	15.84	17.28	18.72	20.16	21.60	23.04	24.48	25.92	27.36	28.80
26 x 75	17.35	18.93	20.51	22.09	23.67	25.24	26.82	28.40	29.98	31.56
28 x 75	18.21	19.86	21.51	23.16	24.81	26.48	28.13	29.78	31.43	33.08
28 x 79	19.14	20.88	22.62	24.36	26.10	27.84	29.58	31.32	33.06	34.80
30 x 36	10.67	11.64	12.61	13.58	14.55	15.52	16.49	17.46	18.43	19.40
30 x 67	17.16	18.72	20.28	21.84	23.40	24.96	26.52	28.08	29.64	31.20
30 x 75	18.78	20.49	22.20	23.91	25.62	27.32	29.03	30.74	32.45	34.16
30 x 79	19.66	21.45	23.22	25.01	26.79	28.60	30.38	32.15	33.94	35.72

4. See following chart for calculating additional **Light Amperage** for "ELS" Electronic Lighting:

“ELS” Lighting System 120 Volt Light Amperage (per frame section)					
No. Doors:	1	2	3	4	5
No. “ELS” Lights:	2	3	4	5	6
LAMPS LENGTH	TOTAL AMPS				
48”	0.92	1.45	1.84	2.37	2.76
60”	1.30	2.02	2.60	3.32	3.90
72”	1.31	2.07	2.62	3.38	3.93

79. Heat Load in BTU/Hr for Model 101 Normal Temp Glass, Door Rail, Frame Heaters and “ELS” Electronic Lighting System (Per Door, with Doors Closed @ 75°F Store Ambient)

MODEL 101 “ELS” NORMAL TEMPERATURE					
(2-PANE NON-HEATED GLASS – CASE TEMP 38°F)					
DOOR SIZE	1 DOOR	2 DOOR	3 DOOR	4 DOOR	5 DOOR
24 x 36	336	572	808	1044	1281
24 x 67	524	908	1291	1674	2058
24 x 75	589	1018	1448	1877	2306
26 x 67	542	942	1342	1743	2143
26 x 75	608	1056	1505	1953	2401
28 x 75	627	1094	1562	2029	2496
28 x 79	643	1125	1608	2091	2574
30 x 36	365	630	896	1161	1426
30 x 67	576	1010	1445	1879	2314
30 x 75	646	1132	1619	2105	2591
30 x 79	663	1165	1668	2171	2674

MODEL 101 NORMAL TEMPERATURE					
(3-PANE NON-HEATED GLASS OR 2-PANE REFL. NHG – CASE TEMP 33°F)					
DOOR SIZE	1 DOOR	2 DOOR	3 DOOR	4 DOOR	5 DOOR
24 x 36	349	598	847	1097	1346
24 x 67	541	940	1340	1740	2139
24 x 75	606	1053	1499	1946	2392
26 x 67	557	973	1389	1805	2221
26 x 75	624	1089	1553	2018	2482
28 x 75	642	1125	1607	2090	2572
28 x 79	658	1156	1655	2153	2651
30 x 36	378	656	934	1212	1490
30 x 67	590	1038	1487	1935	2384
30 x 75	660	1161	1661	2162	2662
30 x 79	677	1194	1711	2228	2746

MODEL 101 NORMAL TEMPERATURE					
(2-PANE HEATED GLASS – CASE TEMP 31°F)					
DOOR SIZE	1 DOOR	2 DOOR	3 DOOR	4 DOOR	5 DOOR
24 x 36	415	731	1046	1361	1677
24 x 67	658	1174	1691	2208	2724
24 x 75	736	1313	1889	2466	3043
26 x 67	682	1223	1764	2305	2846
26 x 75	763	1367	1970	2574	3177
28 x 75	790	1421	2051	2682	3312
28 x 79	814	1467	2121	2775	3429
30 x 36	458	816	1174	1532	1890
30 x 67	731	1321	1910	2500	3090
30 x 75	817	1475	2132	2790	3447
30 x 79	842	1524	2206	2888	3570

NOTE: Add 10-20% to above values depending on door opening frequency.

80. Electrical Information for Model 2100 Low Temp Doors, Frames & “ELS” Electronic Lighting System Heater Amperages @ 120 Volts

NUMBER OF DOORS:	1	2	3	4	5	6	7	8	9	10
STYLE: Low temp doors with heaters, 3-Pane Heated Reflective Glass (5.75 W/SQ. FT.)										
APPLICATION: Case Temperature -10°F, Humidity 74% or less, @ 75°F ambient.										
24 x 36	1.11	2.19	3.24	4.23	5.29	6.48	7.47	8.46	9.52	10.58
24 x 67	1.84	3.37	4.94	6.54	8.14	9.88	11.48	13.08	14.68	16.28
24 x 75	1.98	3.65	5.38	7.18	8.95	10.76	12.56	14.36	16.13	17.90
26 x 67	1.97	3.71	5.40	7.17	8.86	10.80	12.57	14.34	16.03	17.72
26 x 75	2.12	3.97	5.77	7.58	9.38	11.54	13.35	15.16	16.96	18.76
28 x 75	2.16	4.11	6.15	8.08	10.06	12.30	14.23	16.16	18.14	20.12
28 x 79	2.33	4.23	6.28	8.28	10.30	12.56	14.56	16.56	18.58	20.60
30 x 36	1.30	2.60	3.82	5.15	6.28	7.64	8.97	10.30	11.43	12.56
30 x 67	2.07	3.91	5.69	7.63	9.39	11.38	13.32	15.26	17.02	18.78
30 x 75	2.23	4.23	6.23	8.24	10.19	12.46	14.47	16.48	18.43	20.38
30 x 79	2.37	4.46	6.51	8.70	10.74	13.02	15.21	17.40	19.44	21.48

- NOTES:**
1. All amperages are design amperages subject to the following tolerances: heated glass +/- 8%.
 2. Although the amperages are calculated at 120 volts, all doors are designed to operate without sweating when used within the application parameters with a voltage range of +/- 10%.
 3. Design parameters do not make allowances for factors such as air leaks or unusual air flow patterns within cases; therefore, some sweating may occur when upper limits of temperature or humidity are encountered.
 4. See following chart for calculating additional **Light Amperage** for “ELS” Electronic Lighting:

“ELS” Lighting System 120 Volt Light Amperage (per frame section)					
No. Doors:	1	2	3	4	5
No. “ELS” Lights:	2	3	4	5	6
LAMPS LENGTH	TOTAL AMPS				
48”	0.92	1.45	1.84	2.37	2.76
60”	1.30	2.02	2.60	3.32	3.90
72”	1.31	2.07	2.62	3.38	3.93

	11	12	13	14	15	16	17	18	19	20
24 x 36	11.70	12.69	13.75	14.81	15.87	16.92	17.98	19.04	20.10	21.16
24 x 67	18.02	19.62	21.22	22.82	24.42	26.16	27.76	29.36	30.96	32.56
24 x 75	19.74	21.54	23.31	25.08	26.85	28.72	30.49	32.26	34.03	35.80
26 x 67	19.74	21.51	23.20	24.89	26.58	28.68	30.37	32.06	33.75	35.44
26 x 75	20.93	22.74	24.53	26.34	28.14	30.32	32.12	33.91	35.72	37.52
28 x 75	22.31	24.24	26.27	28.20	30.18	32.32	34.30	36.33	38.26	40.24
28 x 79	22.84	24.84	26.88	28.88	30.90	33.12	35.14	37.18	39.18	41.20
30 x 36	14.12	15.45	16.58	17.71	18.84	20.60	21.73	22.86	23.99	25.12
30 x 67	20.95	22.89	24.65	26.41	28.17	30.52	32.28	34.04	35.80	37.56
30 x 75	22.71	24.72	26.67	28.62	30.57	32.96	34.91	36.86	38.81	40.76
30 x 79	23.91	26.10	27.99	30.18	32.22	34.80	36.84	38.73	40.92	42.96

81. Heat Load in BTU/Hr for Model 2100 Normal Temp Glass, Door Rail, Frame Heaters and “ELS” Electronic Lighting System (Per Door, with Doors Closed @ 75°F Store Ambient)

MODEL 2100 “ELS” NORMAL TEMPERATURE					
(3-PANE NON-HEATED GLASS – CASE TEMP 38°F)					
DOOR SIZE	1 DOOR	2 DOOR	3 DOOR	4 DOOR	5 DOOR
24 x 36	306	513	719	925	1132
24 x 67	469	797	1125	1453	1781
24 x 75	527	894	1262	1629	1996
26 x 67	482	822	1162	1503	1843
26 x 75	541	922	1303	1684	2066
28 x 75	555	950	1345	1740	2135
28 x 79	566	973	1380	1787	2193
30 x 36	328	556	784	1012	1240
30 x 67	507	872	1237	1603	1968
30 x 75	569	977	1386	1795	2204
30 x 79	581	1002	1423	1845	2266

82. Heat Load in BTU/Hr for Model 2100 Low Temp Glass, Door Rail, Frame Heaters and “ELS” Electronic Lighting System (Per Door, with Doors Closed @ 75°F Store Ambient)

MODEL 2100 “ELS” LOW TEMPERATURE – HEATED GLASS (3-PANE REFLECTIVE HEATED GLASS – CASE TEMP -10°F)					
DOOR SIZE	1 DOOR	2 DOOR	3 DOOR	4 DOOR	5 DOOR
24 x 36	495	887	1278	1668	2059
24 x 67	780	1410	2040	2669	3299
24 x 75	874	1577	2280	2983	3686
26 x 67	815	1479	2143	2807	3472
26 x 75	908	1646	2384	3122	3860
28 x 75	947	1724	2501	3277	4054
28 x 79	973	1776	2578	3381	4184
30 x 36	557	1008	1459	1910	2361
30 x 67	879	1607	2335	3063	3791
30 x 75	979	1787	2596	3404	4212
30 x 79	1009	1848	2687	3526	4365

NOTE: Add 10-20% to above values depending on door opening frequency.

83. Electrical Information for Model 2100 Normal Temp Doors, Frames & “ELS” Electronic Lighting System Heater Amperages @ 120 Volts

NUMBER OF DOORS:	1	2	3	4	5	6	7	8	9	10
STYLE: Normal temp doors without heaters, 3-Pane Non-Heated Glass										
APPLICATION: Case Temperature 38°F, Humidity 70% @ 75°F ambient.										
24 x 36	0.27	0.54	0.81	1.08	1.35	1.62	1.89	2.16	2.43	2.70
24 x 67	0.42	0.84	1.26	1.68	2.10	2.52	2.94	3.36	3.78	4.20
24 x 75	0.46	0.92	1.37	1.83	2.29	2.74	3.20	3.66	4.12	4.58
26 x 67	0.43	0.86	1.28	1.71	2.14	2.56	2.99	3.42	3.85	4.28
26 x 75	0.47	0.95	1.42	1.89	2.37	2.84	3.31	3.78	4.26	4.74
28 x 75	0.50	0.99	1.49	1.99	2.48	2.98	3.48	3.98	4.47	4.96
28 x 79	0.52	1.03	1.55	2.06	2.58	3.10	3.61	4.12	4.64	5.16
30 x 36	0.31	0.62	0.94	1.25	1.56	1.88	2.19	2.50	2.81	3.13
30 x 67	0.46	0.93	1.39	1.86	2.32	2.78	3.25	3.72	4.18	4.64
30 x 75	0.49	0.98	1.47	1.96	2.45	2.94	3.43	3.92	4.41	4.90
30 x 79	0.51	1.02	1.52	2.03	2.54	3.04	3.55	4.06	4.57	5.08

NUMBER OF DOORS:	1	2	3	4	5	6	7	8	9	10
STYLE: Normal temp doors without heaters, 3-Pane Non-Heated Glass										
APPLICATION: Case Temperature 38°F, Humidity 65% @ 75°F ambient (Low Energy Product)										
24 x 36	0.17	0.33	0.52	0.69	0.87	1.04	1.21	1.38	1.56	1.74
24 x 67	0.27	0.53	0.80	1.06	1.33	1.60	1.86	2.12	2.39	2.66
24 x 75	0.29	0.59	0.88	1.17	1.47	1.76	2.05	2.34	2.64	2.94
26 x 67	0.28	0.55	0.83	1.10	1.38	1.66	1.93	2.20	2.48	2.76
26 x 75	0.28	0.57	0.85	1.14	1.42	1.70	1.99	2.28	2.56	2.84
30 x 36	0.20	0.38	0.60	0.79	0.99	1.20	1.39	1.58	1.78	1.99
30 x 67	0.30	0.59	0.89	1.19	1.49	1.78	2.08	2.38	2.68	2.97
30 x 75	0.31	0.62	0.94	1.25	1.56	1.88	2.19	2.50	2.81	3.13

- NOTES:**
1. All amperages are design amperages subject to the following tolerances: non-heated glass +/- 5%.
 2. Although the amperages are calculated at 120 volts, all doors are designed to operate without sweating when used within the application parameters with a voltage range of +/- 10%.
 3. Design parameters do not make allowances for factors such as air leaks or unusual air flow patterns within cases; therefore, some sweating may occur when upper limits of temperature or humidity are encountered.
 4. See following chart for calculating additional **Light Amperage** for “ELS” Electronic Lighting:

“ELS” Lighting System 120 Volt Light Amperage (per frame section)					
No. Doors:	1	2	3	4	5
No. “ELS” Lights:	2	3	4	5	6
LAMPS LENGTH	TOTAL AMPS				
48”	0.92	1.45	1.84	2.37	2.76
60”	1.30	2.02	2.60	3.32	3.90
72”	1.31	2.07	2.62	3.38	3.93

	11	12	13	14	15	16	17	18	19	20
24 x 36	2.97	3.24	3.51	3.78	4.05	4.32	4.59	4.86	5.13	5.40
24 x 67	4.62	5.04	5.46	5.88	6.30	6.72	7.14	7.56	7.98	8.40
24 x 75	5.03	5.49	5.95	6.41	6.87	7.32	7.78	8.24	8.70	9.16
26 x 67	4.70	5.13	5.56	5.99	6.42	6.84	7.27	7.70	8.13	8.56
26 x 75	5.20	5.67	6.15	6.63	7.11	7.56	8.04	8.52	9.00	9.48
28 x 75	5.47	5.97	6.45	6.95	7.44	7.96	8.45	8.93	9.43	9.92
28 x 79	5.67	6.18	6.71	7.22	7.74	8.24	8.76	9.29	9.80	10.32
30 x 36	3.44	3.75	4.06	4.37	4.69	5.00	5.31	5.62	5.93	6.25
30 x 67	5.11	5.58	6.04	6.50	6.97	7.44	7.90	8.36	8.82	9.30
30 x 75	5.39	5.88	6.37	6.86	7.35	7.84	8.33	8.82	9.31	9.80
30 x 79	5.58	6.09	6.60	7.11	7.62	8.12	8.63	9.14	9.65	10.16

	11	12	13	14	15	16	17	18	19	20
24 x 36	1.90	2.07	2.25	2.43	2.61	2.76	2.94	3.12	3.30	3.48
24 x 67	2.92	3.18	3.45	3.72	3.99	4.24	4.51	4.78	5.05	5.32
24 x 75	3.22	3.51	3.81	4.11	4.41	4.68	4.98	5.28	5.58	5.88
26 x 67	3.03	3.30	3.58	3.86	4.14	4.40	4.68	4.96	5.24	5.52
26 x 75	3.13	3.42	3.70	3.98	4.26	4.56	4.84	5.12	5.40	5.68
30 x 36	2.18	2.37	2.57	2.77	2.97	3.16	3.36	3.56	3.76	3.95
30 x 67	3.27	3.57	3.87	4.17	4.46	4.76	5.06	5.36	5.66	5.95
30 x 75	3.44	3.75	4.06	4.37	4.69	5.00	5.31	5.62	5.93	6.25

84. Troubleshooting

1. **Electrical:** Low voltage supply (less than 108V on 120V systems) results in significantly lower wattage. Lower wattage will decrease the efficiency of heaters and lamps.

A. Glass Condensation:

1. No Power? Check:

- a. Power supply
- b. Relative humidity in room area
- c. Hinge Pin Wiring
- d. Case temperature
- e. Hinge Pin plugged into door female plug
- f. Incorrect wiring
- g. Faulty Energy Management System (Sensor)

2. Low Voltage? Check:

- a. Voltage at main – low voltage
- b. Energy Management System (Sensor)

B. Door and Frame Rail Condensation:

1. No Power? Check:

- a. Power supply
- b. Relative humidity in room area
- c. Hinge Pin Wiring
- d. Case temperature
- e. Hinge Pin installed in female plug in door
- f. High velocity fans on back of frame
- g. Energy Management System (Sensor)

2. Low Voltage? Check:

- a. Supply voltage – low voltage

- b. Energy Management System (Sensor)

2. Mechanical:

A. Door Not Sealing? Check:

- 1. Magnetic gasket (Replace if necessary)
- 2. Torquemaster adjustment
- 3. Hold-Open
- 4. Defective frame plastic
- 5. Frame or door out of square

B. Door Will Not Close?

- 1. See instructions 2A, 1 through 5 above

C. Door Saw Toothed?

- 1. Door or frame out of square? (Square to the nearest 1/16" of net opening)
- 2. Torquemaster adjustment
- 3. Worn Hinge Pin hole?
- 4. Case not level?
- 5. Frame not shimmed properly?

3. Ballast/Lamps:

A. Lamps Will Not Start:

- 1. Ballast failure?
- 2. Incorrect ballast?
- 3. Incorrect wiring?
- 4. Incorrect bulb?
- 5. Poor contact between bulb and socket?
- 6. Case too old? (Lamps will usually light, but they will be very dim)
- 7. Incorrect socket wiring?
- 8. No ground?

B. Lamp Flickering:

- 1. Incorrect ballast?
- 2. Defective bulb?
- 3. Incorrect voltage?
- 4. Bulbs without shields?

C. Slow-Starting Bulb:

- 1. Improper wiring?
- 2. Poor lamp and socket connections?
- 3. Voltage too low?

4. Defective bulbs?
 5. Incorrect ballast?
 6. Case too cold?
- D. Shortened Lamp Life:
1. Incorrect wiring of lamp or ballast?
 2. Incorrect socket connection?
 3. Incorrect bulbs or ballast?
- E. Blinking Lamps:
1. Voltage too high?
 2. Wrong bulbs or ballast?
 3. Incorrect socket wiring?
 4. Incorrect number of lamps for ballast?
- F. Ballast (Humm-Noise):
1. Defective ballast?
 2. Loose ballast can or cover?
 3. Ballast mounted incorrectly?

85. Safety Precautions

1. Always turn off power to case, doors and frames before starting work on equipment.
2. Always use a qualified electrician for electrical work.
3. Always wear safety glasses when working on equipment.

86. Tips

1. **Never splice door or frame heater wires.** Complete replacement recommended.
2. When installing gasket and plastics, use a liquid soap.
3. Keep doors and frames clean.
4. For binding gasket or plastic parts, use a food grade silicone.
5. Always replace lamp shields when lamps are replaced.
6. Preventive maintenance is the key to door and frame longevity.



COMPANY POLICIES, TERMS OF SALE, AND WARRANTY

The following terms and conditions shall apply to all transactions and agreements between Anthony, Inc. ("Anthony") and the other party to such transaction or agreement ("Buyer") with respect to the purchase of any goods from Anthony and/or the extension of credit by Anthony to Buyer for such purchase.

1. PRICE. Prices shown on the face of the sales invoice are F.O.B. the place of shipment as designated by Anthony, packaged for shipment and subject to change without notice.

2. TERMS OF CREDIT. All credit terms are net 30 days from date of invoice. Any deductions from the net invoice amount must be approved by a representative of Anthony authorized to make such changes. If credit is extended to Buyer, Anthony reserves the right to revoke such credit if Buyer fails to make timely payment for any goods delivered. Anthony reserves the right to require payment or other assurances which it deems necessary prior to the shipment of any goods, if, in Anthony's opinion, exercised in Anthony's subjective, good faith judgment, the Buyer's financial condition has deteriorated or the risk of non-payment has otherwise increased. Credit is subject to approval upon receipt of completed credit application. Any goods shipped prior to credit approval shall be shipped C.O.D., "Cashiers Check", or pre-payment. A \$25.00 charge will be applied for each returned check. Goods may not be returned for credit unless prior authorization and an authorization number have been granted by Anthony. A 1 1/2 % per month charge will be assessed on past due amounts.

3. SHIPMENT OF GOODS / RETURN OF GOODS. Every effort will be made to ship the goods on the scheduled shipment date and to maintain production schedules consistent therewith provided however, Anthony shall not be liable for any claims or consequential damages arising from the failure to meet any scheduled shipping dates. If Buyer refuses shipment of any standard catalog products under an acknowledged order and those products are consistent with that order and are not delivered damaged or defective, then Buyer will be responsible for (i) return shipment of the products to Anthony in original shipping containers; (ii) return freight to Anthony prepaid by Buyer; and (iii) a restocking charge to be determined by Anthony of not less than twenty-five percent (25%) of the sales price. Buyer assumes the risk of any return shipment damage or loss, the cost of which will be assessed by Anthony and added to the restocking charge. No custom products or custom sizes of catalog items may be returned to Anthony for credit unless those products are not consistent with an acknowledged order or they are defective. If they are defective, Anthony reserves the right to cure the defect at the ship-to location. Costs for special packaging and/or handling requested by Buyer will be billed to Buyer. Shipping terms are specified on the face of Anthony's quotation and/or price list, as applicable. Unless otherwise specified by Buyer in writing, Anthony shall select the method of shipment and direct shipment of materials to the specified delivery address of Buyer. In the event of any general freight increase or any governmental ruling or regulation that results in increased freight costs, Anthony may, without any advance notice, invoice Buyer for such additional costs. Acceptance and rejections of glass sheets, assembled sealed glass units, and finished doors shall be in accordance with the defect criteria set forth in Industry Specification ASTM C1036-06 Standards, level Q3.

4. RISK OF LOSS. Subject to security interests retained by Anthony until payment for the goods is received in full, the title to such goods and risk of loss or damages thereto pass to Buyer upon completion of loading of goods on carrier at Anthony's factory. Buyer will unload shipments promptly and Buyer will be liable for any additional charges such as demurrage, storage, and labor incurred by its failure to do so. Any claims by Buyer for damages to the goods incurred during shipping shall be made to the carrier.

5. WARRANTIES. The products which Anthony manufacture and offer for sale are warranted to: (i) be free from defects in materials and workmanship; and (ii) perform in accordance with applicable refrigeration standards as of the date of manufacture for a period of 12 months from the date and place of shipment, provided that the installation and maintenance of such products have been performed strictly in accordance with Anthony's designated specifications (the "Warranty"). Anthony shall provide all necessary parts and labor at its cost to fulfill said Warranty. All parts will be shipped standard ground freight. The extent of Anthony's liability under the Warranty is limited to the repair or replacement, at Anthony's option, of any non-conforming products without charge, at Anthony's Sylmar manufacturing plant. Additionally, for a period of 10 years from the shipment date, Anthony will replace sealed glass units that are part of an original Anthony-manufactured door if the seal breaks and internal condensation results. Anthony-manufactured LED lighting have a five (5) year component warranty and twelve (12) month labor warranty. The anti-fog coating is only warranted for a period of twelve (12) months from date of shipment. Anthony reserves the right to change its warranty provisions at its sole discretion at any time with or without prior notification of such change.

No Warranty for Non-Standard Products.

A "Non-Standard Product" is any product that is different in any manner from any Anthony product that has been previously designed and manufactured by Anthony in accordance with its standard specifications. A Non-Standard Product also includes any standard Anthony product that has been specially designed or modified to meet a particular Buyer specification, or that contains any additional or substituted product, part, accessory, equipment, fixture, component or material, or that has been assembled, manufactured, produced, or installed by any method or process, which is different from Anthony's standard specifications for such product. Anthony expressly disclaims and make no warranties, express or implied, as to the condition, design, utility, quality, adequacy, or capacity with respect to any standard or Non-Standard Product, including, without limitation, any warranty of merchantability or fitness of such product for a particular purpose or intended use, whether or not such product has been designated by Anthony as a Non-Standard Product.

All Non-Standard Products, whether sold separately, or incorporated and/or attached to standard Anthony products, and all services relating to such products, are sold to and accepted by Buyer "as is" and "with all faults". Without limiting any other provision of this purchase order, Anthony shall have no liability to Buyer for any claim, loss, damage, consequential damages or expense associated with any Non-Standard Product and/or its use or operation, or any other equipment or property of Buyer caused by or alleged to be caused by any such product or its use or operation, whether directly, indirectly, incidentally or consequentially, or by any inadequacy thereof or deficiency or defect therein.

The foregoing exclusion of warranty cannot be modified or waived except as expressly set forth in a writing signed by an officer of Anthony authorized to make such modification or waiver.

THE ABOVE WARRANTY IS GIVEN IN LIEU OF ALL OTHER WARRANTIES, EXPRESSED OR IMPLIED, INCLUDING ANY IMPLIED WARRANTIES OF MERCHANTABILITY OR FITNESS FOR A PARTICULAR PURPOSE. ANTHONY SHALL NOT BE RESPONSIBLE FOR INCIDENTAL OR CONSEQUENTIAL DAMAGES INCLUDING BUT NOT LIMITED TO INJURY TO PERSONS OR PROPERTY.

6. ACCEPTANCE OF PRODUCTS BY BUYER/CLAIMS: Upon delivery, shipments must be inspected for damage, loss or shortage prior to acceptance from the carrier. If damage or shortage exists with respect to any shipment and it is not concealed, Buyer shall secure a notation of such damage or shortage from the delivering agent on the freight bill or delivery receipt. If damage is concealed, Buyer must notify Anthony within five (5) days of its delivery and hold the merchandise for its inspection. Any claims for visible loss or damage should be filed by Buyer with Anthony in writing immediately upon receipt of the materials. All claims of Buyer that materials delivered do not conform to the accepted order shall be handled as claims for breach of warranty and Buyer shall be limited to those remedies available for breach of warranty.

7. CLAIMS BY BUYER. Anthony shall thereupon be afforded a reasonable opportunity to inspect the goods. All claims not made in the time period and manner specified above shall be deemed waived. All actions, claims or defenses by Buyer shall be deemed waived unless commenced or asserted within six (6) months of receipt of the goods. No claims for visible, external damage or shortage will be allowed unless they are accompanied by an inspection report or signed delivery receipt noting such loss or damage signed by a representative of the carrier and forwarded to the Anthony Vice President, Marketing & Sales within 30 days of the invoice date.

8. CANCELLATION. Orders may not be canceled after receipt by Anthony unless Anthony consents in writing to such cancellation. Cancellation will be granted only on terms indemnifying Anthony against any loss resulting from such action. At minimum, Buyer will be liable for all cost incurred on the order through the cancellation date.

9. CHANGES BY ANTHONY. Anthony reserves the right to change design, colors and specifications of any goods without notice to Buyer.

10. DEFAULT. If Buyer defaults or fails to pay on the purchase of any goods or if a petition in bankruptcy is filed by or against Buyer, Anthony, in addition to other remedies, may repossess any goods which were previously delivered and for which payment has not been received, and may refuse to make further shipment of goods. Buyer agrees to pay Anthony's attorneys' fees, costs and expenses incurred as a result of Buyers default or failure to pay, including but not limited to any collection or repossession expenses.

11. ENTIRE AGREEMENT AND AMENDMENT. The terms specified herein constitute the entire agreement between Anthony and Buyer with respect to the sale and purchase of the goods and any extension of credit. If Anthony and Buyer agree to amend or modify any terms and conditions specified herein, such amendment or modification must be expressly stated on the face of the sales invoice or by a written agreement duly executed by an officer of Anthony and the Buyer. The terms specified herein shall control in the event of any variance between these terms and any terms contained in Buyer's purchase orders.

12. GOVERNING LAW. This purchase order, any agreements between Anthony and Buyer and all other claims that arise between the parties, whether sounding in contract or tort, shall be governed by, construed and enforced in accordance with the laws of the State of California. By entering into this purchase order and any other agreement with Anthony, Buyer consents to the jurisdiction of the courts of the State of California to determine all claims between the parties, regardless of whether said claims are contract claims, tort claims, patent claims, trademark claims or copyright claims. Venue of any lawsuit (State or Federal) against Anthony must be filed in Los Angeles County, California. Service of process on Buyer may be made by registered mail addressed to the Buyer.

13. SEVERABILITY. If any provision of the terms and conditions specified herein shall be deemed invalid or unenforceable, the remaining terms and conditions shall be construed as though such provision does not appear herein and shall be otherwise fully enforceable.

14. HEADINGS. The section headings contained herein have been inserted for convenient reference and shall not be considered in any questions of interpretation or construction of any agreements between Anthony and Buyer.

Anthony products are covered by one or more of the following United States Patents: RE035392, 5301092, 5720540, 5879070, 5895111, 5910083, 5902034, 5959816, 6010227, 6298615, 6302036, 6302557, 6389993, 6343405, 5116274, 5244273, 5255473, 5333355, 5471372, 5645330, 6632100, 6637093, 6638088, 6773130, 6641419, 6490983, 6606832, 6606833, 5884361, D600529, 7603882, 7273299, 7674019, D404935, D395968, D612517, 5622414, 7731395, 8250873 B2.

Anthony products are covered by one or more of the following Foreign Patents: Canada: 2233401, Mexico:185899, 186644, 202491, 238593, 227313, 236090. Other United States and Foreign Patents Pending.

99-18396-W001_E (01/02/2014)