



Model 100F, 100NT & 100PR Doors

**(Including Pass-Thru Door Models
125/127/130)**

Service & Installation



November, 2012

99-20440-I001

Table of Contents

1. Model 100 Door and Frame (Prior to 1983)..... 5

2. Door Installation Instructions Model 100 (Prior to 1983)..... 7

3. Door Handle Replacement 8

4. Torque Rod Replacement..... 8

5. Model 100 Frame (Prior to 1987)..... 9

6. Model 100 Door & Frame (Prior to 1987) 10

7. Model 100PR Door (Reversible - 1987 to Present) 11

8. Model 100PR Frame (Pre-Wired Reversible) 12

9. Models 100/100PR Standard Frame Net Opening Widths 13

10. Models 100/100PR Standard Frame Net Opening Heights 14

11. Frame Installation Instructions Models 100F/100NT/100PR..... 14

12. Hold-Open Replacement 15

13. Reversible/Cordless Door & Hold-Open Installation 17

14. Reversing Frame Hardware (1987 to Present) 20

15. Door Reversing Instructions (1987 to 1990) 20

16. Door Reversing Instructions (1991 to Present)..... 23

17. Pass-Thru Installation..... 24

18. Pass-Thru Models 25

19. Pass-Thru Frame Wiring Diagram 25

20. Frame Sill Plastic Protector Installation 26

21. Contact Plate and Contact Plate Retainer Replacement 27

22. Ordering Replacement Doors 28

23. Torquemaster and/or Casting Replacement..... 28

24. Door Gasket Replacement 29

25. Door Plastic (Cover) Replacement 30

26. Door Handle Replacement 30

27. Side Access Plate Replacement..... 31

28. Door Female Plug Replacement (1987 to 1991) 31

29. Door Female Plug Replacement (1991 to Present)..... 32

30. Frame Female Socket Replacement 32

31. Door Heater Replacement (1987 to 1991)..... 33

32. Door Heater Replacement (1991 to Present) 33

33. Hinge Pin Replacement (1987 to 1991)..... 34

Model 100F/100NT/100PR Door Service & Installation

34. Hinge Pin Replacement (1991 to Present)	34
35. Wiring Instructions, Heated and Non-Heated Glass (1991 to Present).....	35
36. Torque Rod Replacement (1987 to 1991)	35
37. Torque Rod Replacement (1991 to Present).....	35
38. Front Bumper Bar Field Installation	36
39. Door Cylinder Lock Replacement or Repair	36
40. P.O.M. Lock Installation.....	37
41. P.O.M. Lock Retrofit Installation	38
42. Ordering Replacement Frames	39
43. Glass Replacement (Reglazing).....	40
44. Humastat Installation Procedure.....	42
45. Model 100FR Humastat.....	44
46. Frame Heater Wire Replacement	44
47. Frame Heater Wiring Diagram Model 100PR (Reversible) Low Temp	46
48. Frame Heater Wiring Diagram Model 100PR (Reversible) Normal Temp	46
49. Model 100 Shelf Assembly Catalog Size/Shelf Size	47
50. Shelving Installation Instructions (Prior to 1984).....	47
51. Four-Post Stabilizer Bar Installation	50
52. Four-Post Shelving System Installation (After 1984)	51
53. Plastic Tag Molding Installation	52
54. Model 100PR Low Temp 120 Volt Ballast & Lamp Wiring Diagram – Pre-Wired 1-Light System (1987 to Present).....	53
55. Model 100PR Ballast Replacement	54
56. Lamp Replacement	55
57. Lamp Socket Replacement.....	55
58. Recessed Lamp Replacement.....	56
59. “Boost & Buck” Transformer Wiring Diagram.....	56
60. Frame Junction Box Wiring (Standard Production).....	57
61. Model 100PR Light Fixture Placement	57
62. Model 100 – Low Temp 120V Ballast & Lamp Wiring Diagram for 1-Light Systems	58
63. Model 100 – Low Temp 120V Ballast & Lamp Wiring Diagram for 2-Light Systems	59
64. Fan Delay Switch Retrofit & Replacement.....	60
65. Klix-on (Thermo-Disc) Installation Instructions	60
66. Dew Point Chart	61

Model 100F/100NT/100PR Door Service & Installation

67.	Electrical Information for Model 100PR Low Temp Doors, Frames & Light Fixtures Amperages @ 120 Volts.....	62
68.	Heat Load in BTU/Hr for Glass, Door Rail, Frame Heaters and Lights (Per Door, with Doors Closed @ 75°F Store Ambient).....	63
69.	Electrical Information for Model 100PR Normal Temp Doors, Frames & Light Fixtures, Amperages @ 120 Volts	64
70.	Electrical Information for Model 100PR Normal Temp Doors, Frames & Light Fixtures, Amperages @ 120 Volts	65
71.	Troubleshooting.....	66
72.	Safety Precautions	68
73.	Tips.....	68

Model 100F/100NT/100PR Door Service & Installation

1. Model 100 Door and Frame (Prior to 1983)

1. Product Prior to 1987

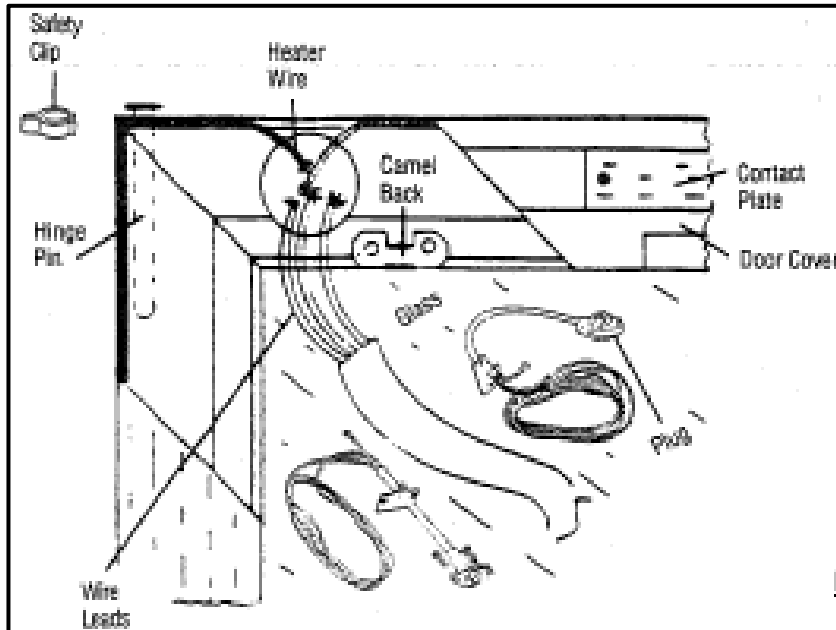

2. Prior to 1984

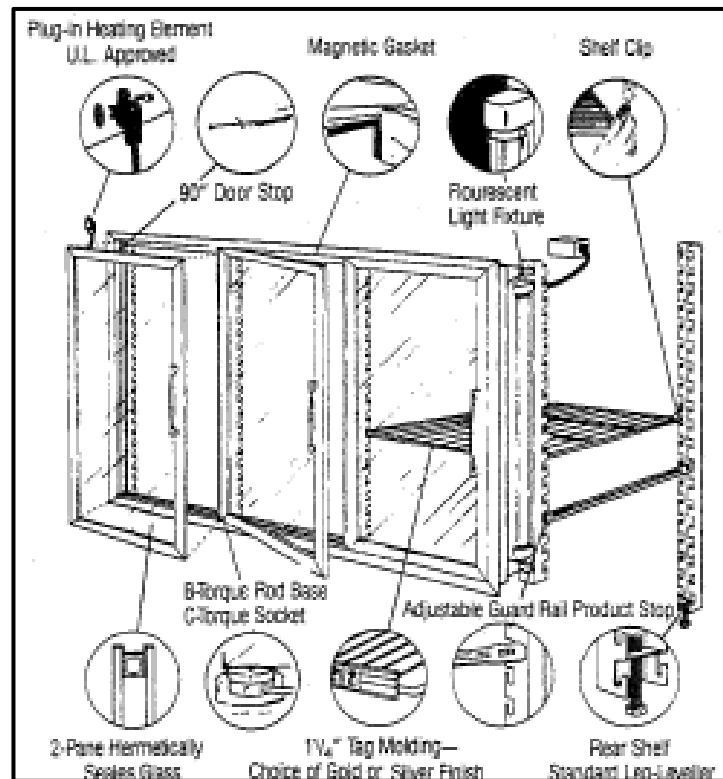

Model 100F/100NT/100PR Door Service & Installation

3. Torque Assembly (Prior to 1983)

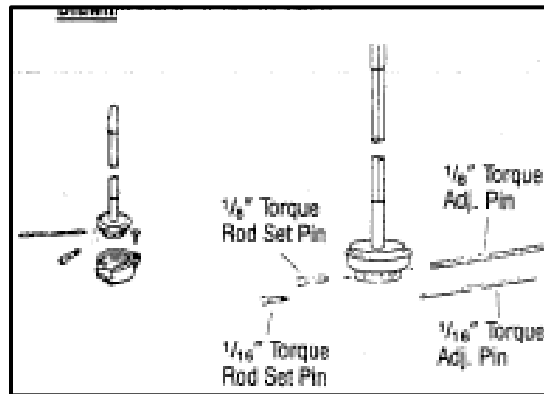

4. Model 100-100F (Prior to 1983)

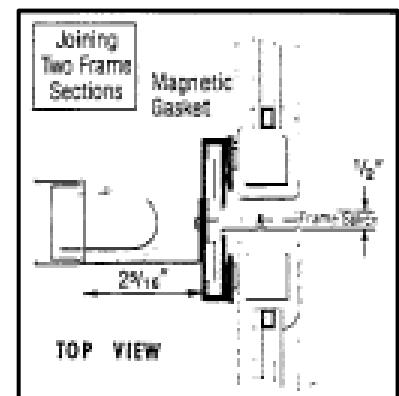
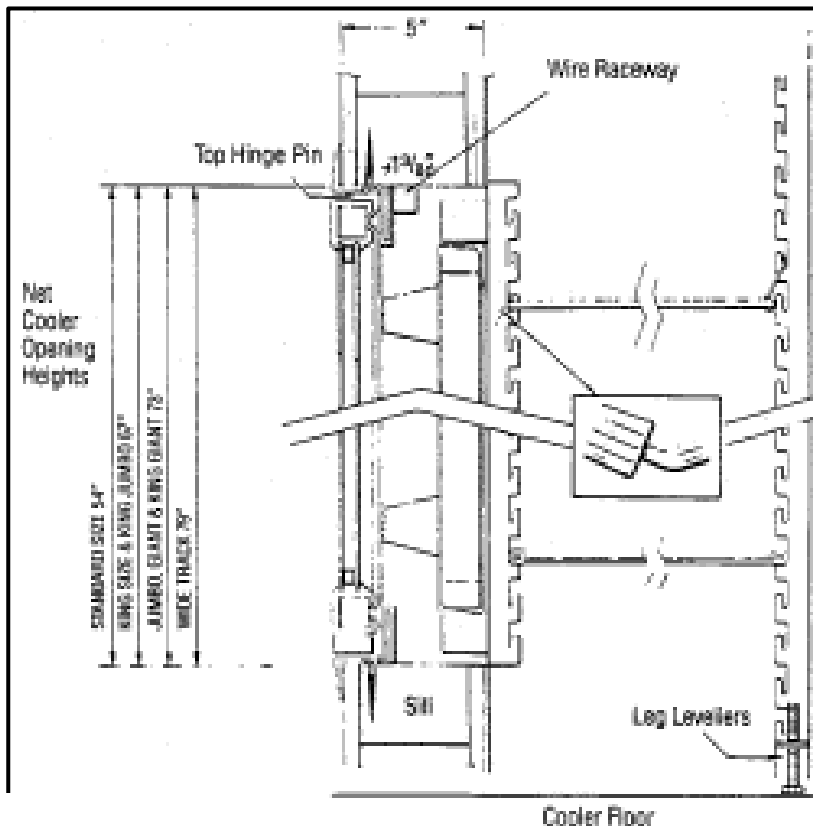

Joining Two Frame Sections

2. Door Installation Instructions Model 100 (Prior to 1983)

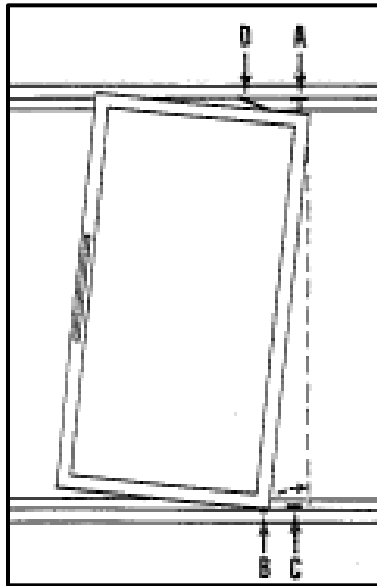

1. Insert top of door into top hinge pin "A".

Safety Precaution: Snap ring must be used on every door. Place snap ring on top hinge pin after installation of every door.

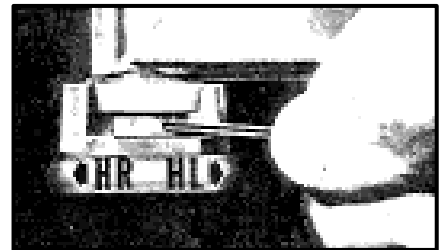
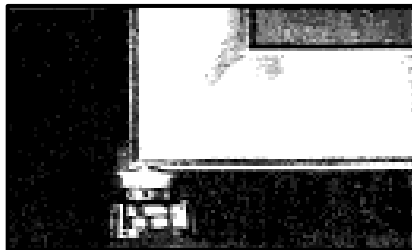

2. Lift up door and insert torque shaft "B" into socket "C". Using two (2) long pins, adjust torque to desired tension and set with one (1) short pin. Both long and short pins are provided.

Note: Do not over-adjust door as this will cause door to slam.

3. Connect 90° door stop arm "D" to slide block on frame. Secure with screw provided.
4. Reverse instructions to remove door.

Caution: Before removing door, extract torque set pin and safety snap ring with a pair of pliers.

Model 100F/100NT/100PR Door Service & Installation

3. Door Handle Replacement

1. To remove handle, insert 5/32" Allen wrench through back side of door frame. Handle screws are contained in door frame.

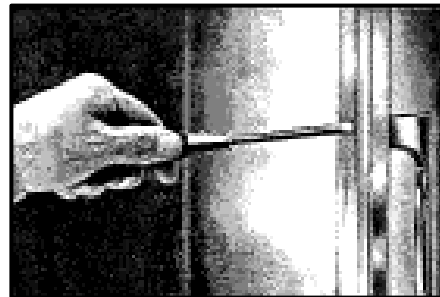
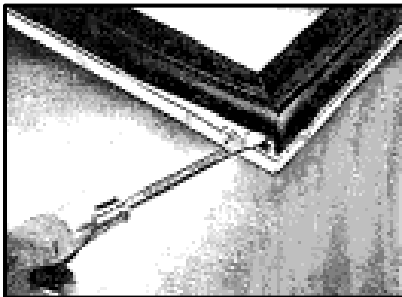

4. Torque Rod Replacement

1. Door does not have to be disassembled to replace torque rod. Drive tapered shaft of torque rod from door as shown below.
2. To replace new torque rod, align torque shaft with key way in door. Tapered shaft must be driven flush with bottom of door.

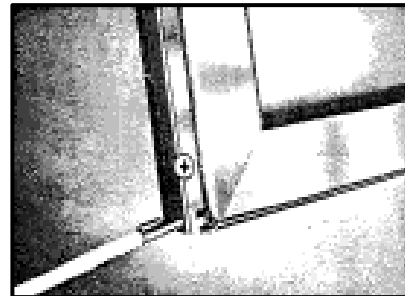
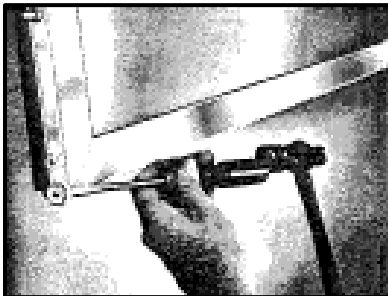

Model 100F/100NT/100PR Door Service & Installation

5. Model 100 Frame (Prior to 1987)

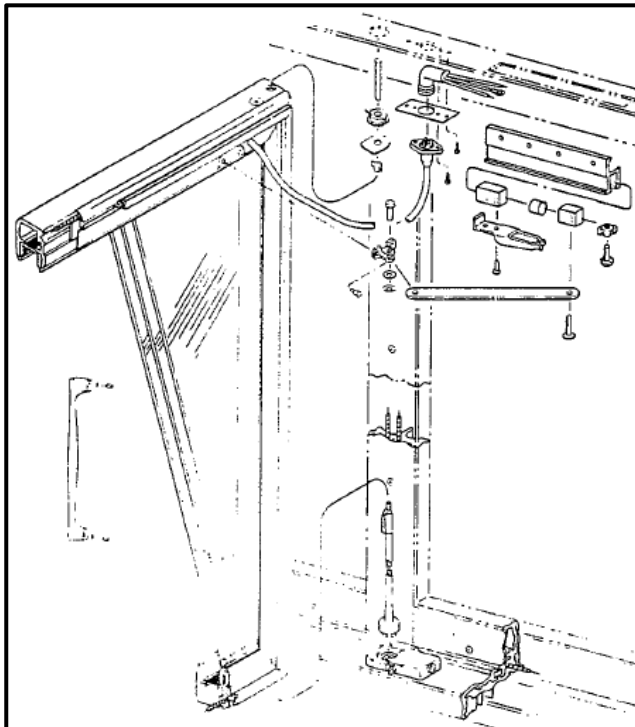

Models 100, 100F, 100NT

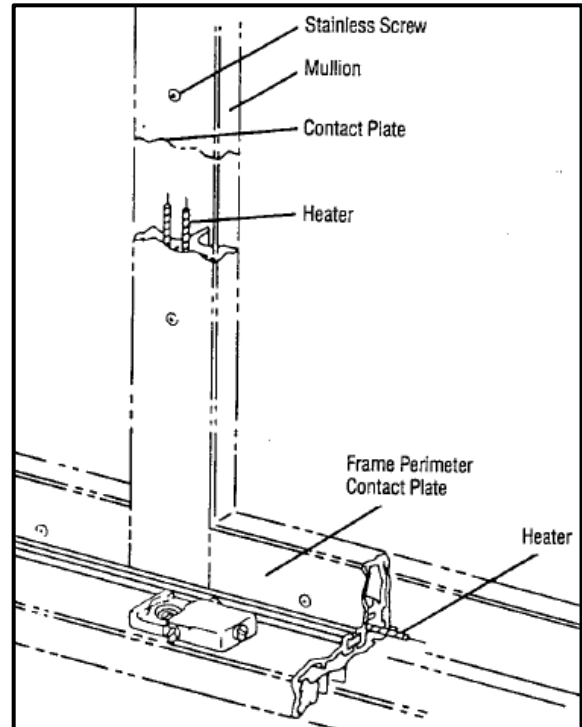

Frame Schematic

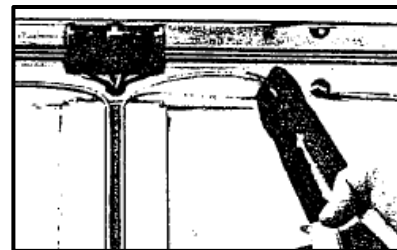
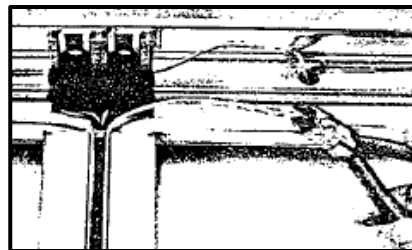
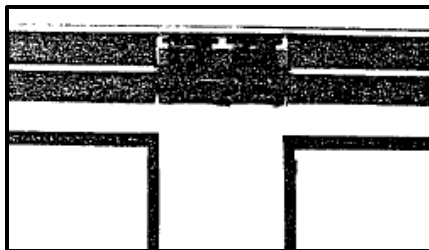

Contact Plate & Heater Replacement

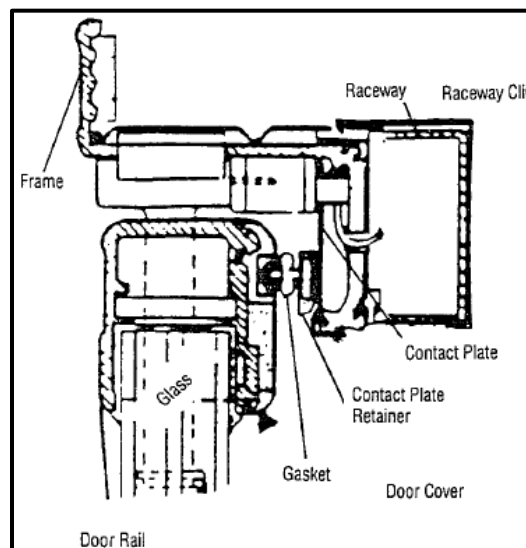

Frame End View

Model 100F/100NT/100PR Door Service & Installation

6. Model 100 Door & Frame (Prior to 1987)

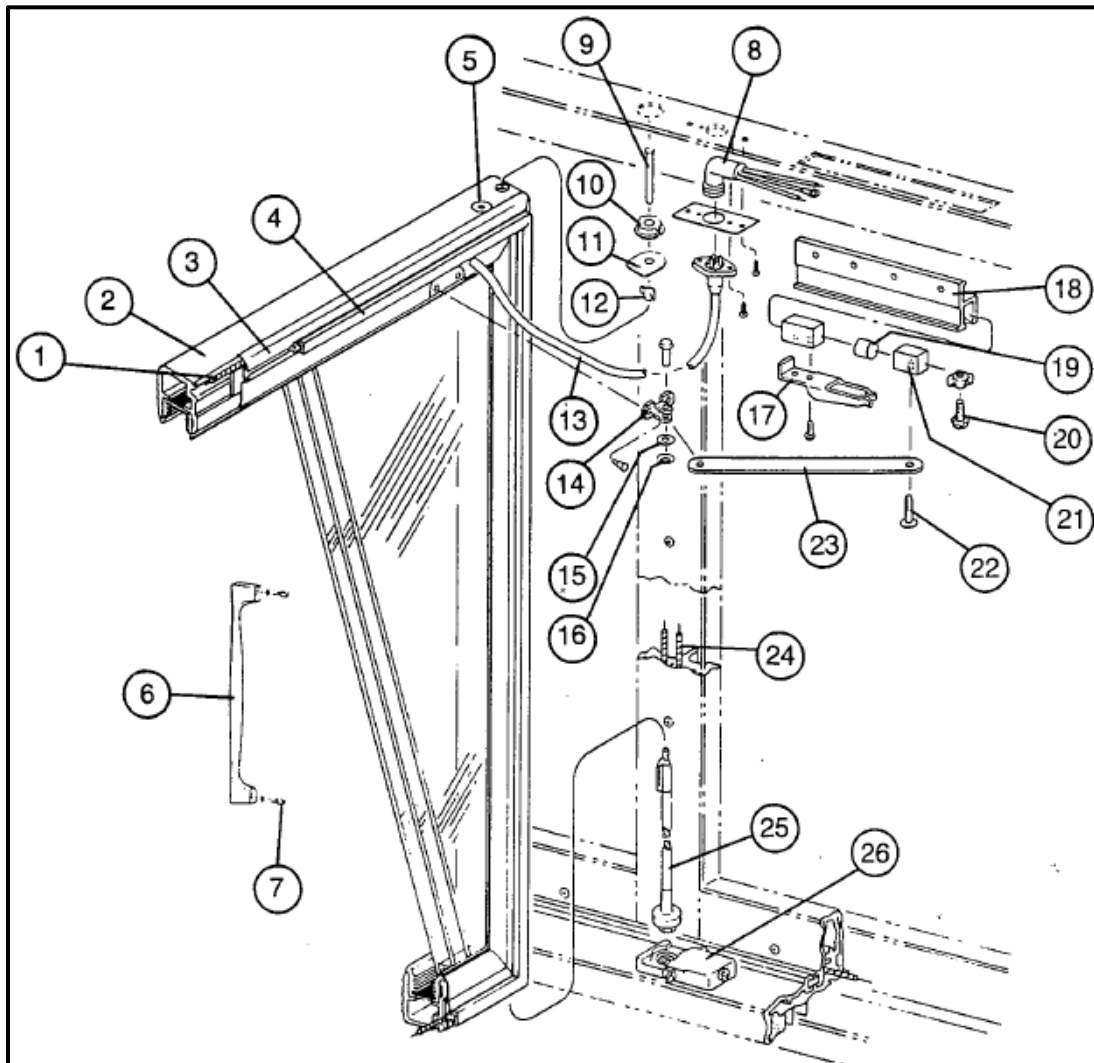

Note: Casting and pin style Torque Rod can easily be updated (converted) to Torquemaster and hex head Torque Rod. Remove Phillips-head screw from torque casting and list casting out of frame. Replace with Torquemaster. Remove pin style torque rod from door and replace with hex head torque rod.

Description	Description	Description	Description
1. Heater Wire	8. Female Plug	15. Camel Back Washer	22. Block Screw
2. Door Rail	9. Hinge Pin	16. Pin Holder	23. 10" Arm
3. Door Plastic	10. Pin Holder	17. Hold-Open	24. Heater Wire
4. Gasket	11. Pin Cover	18. Door Stop	25. Torque Rod
5. Corner Screw	12. Safety Snap Ring	19. Slide Bumper	26. Torquemaster
6. Handle	13. S. J. Cord	20. Nut & Bolt	27. Camel Back Pin
7. Handle Screw	14. Camel Back Hinge	21. Sliding Block	

Model 100F/100NT/100PR Door Service & Installation

7. Model 100PR Door (Reversible - 1987 to Present)

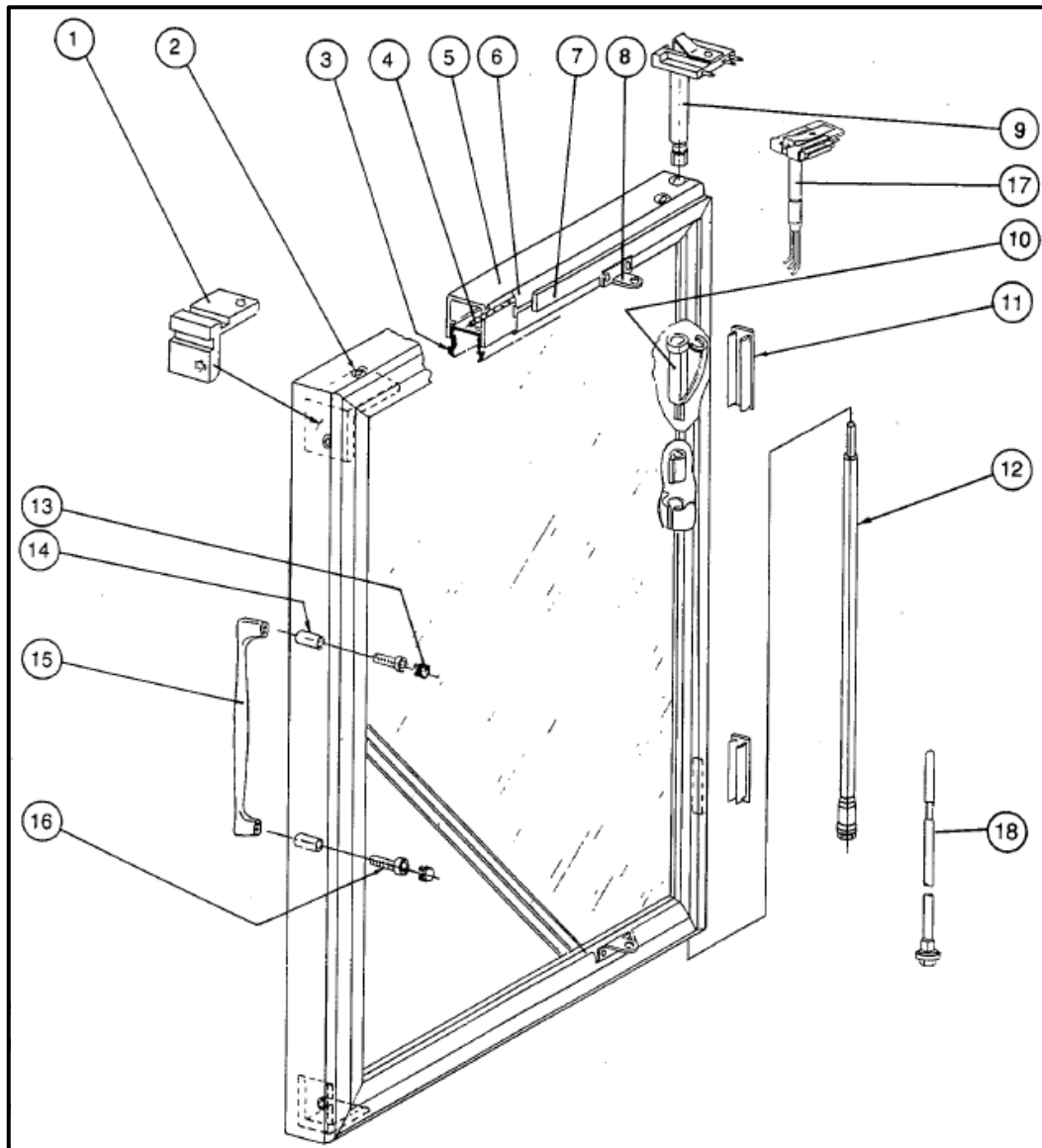

Description	Description	Description
1. Corner Piece	7. Gasket	13. Cap
2. Corner Screw	8. Camel Back	14. Access Tube
3. Glazing Channel	9. Hinge Pin	15. Handle
4. Heater Wire	10. Receptacle	16. Handle Screw
5. Door Rail	11. Cover	17. Hinge Pin
6. Plastic	12. Torque Rod	18. Torque Rod

Model 100F/100NT/100PR Door Service & Installation

8. Model 100PR Frame (Pre-Wired Reversible)

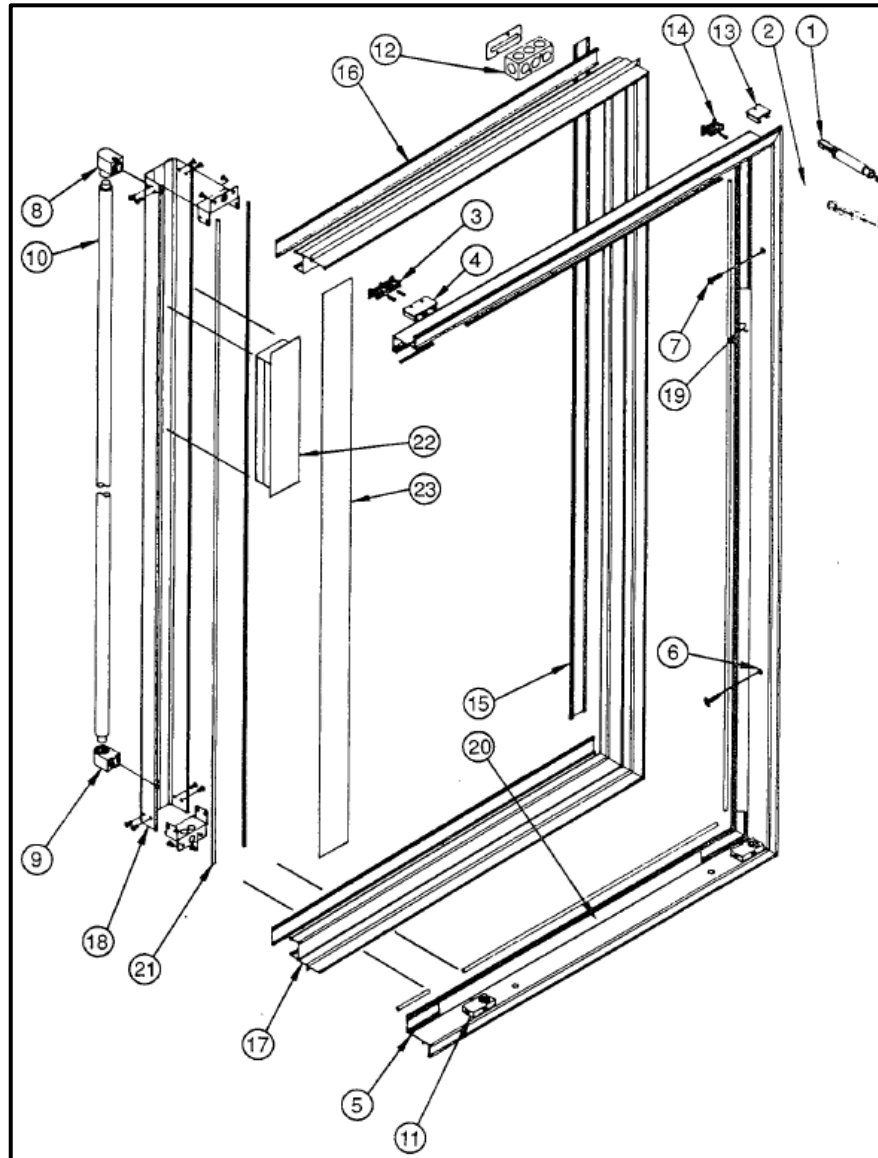

Description	Description	Description
1. Hold-Open (10/15/86-10/90)	9. Bottom Lamp Socket	17. Raceway
2. Hold-Open (10/90)	10. Light Bulb	18. Pre-Wired Ballast Mullion
3. Double Station Socket	11. Torquemaster	19. Vertical Contact Plate
4. Double Station Receptacle	12. Junction Box	20. Horizontal Contact Plate
5. Frame Receptacle	13. Single Station Receptacle	21. Contact Plate Retainer
6. Installation Hole	14. Single Station Socket	22. Pre-Wired Ballast
7. Installation Screw	15. End Raceway Cover	23. Contact Plate Mullion
8. Top Lamp Socket	16. Raceway Cover	

9. Models 100/100PR Standard Frame Net Opening Widths

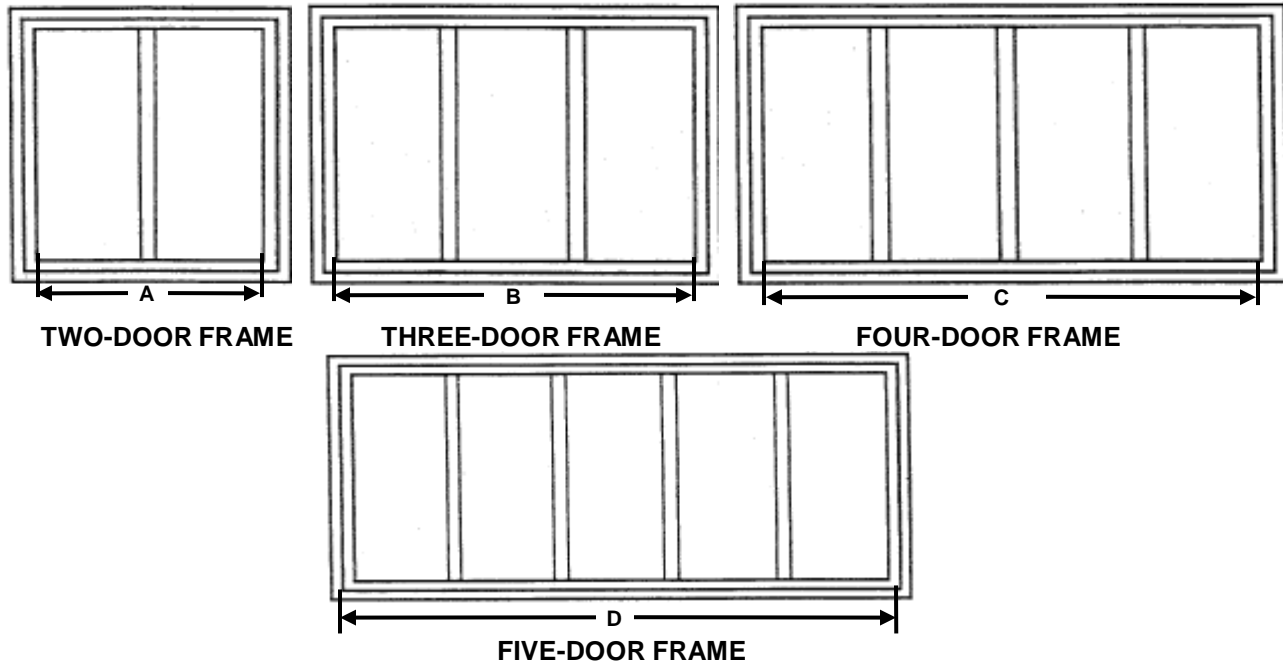

1. Frame Width Data

24" Door (Catalog Size) 23-3/16" Actual Door Width

		A	B	C	D
ENDLESS MULLION	FINISHED FRAME NET OPENING	48-5/8"	72-3/8"	96-1/8"	119-7/8"
FULL FLANGE	FINISHED FRAME NET OPENING	48-7/8"	72-5/8"	96-3/8"	120-1/8"

26" Door (Catalog Size) 26-3/8" Actual Door Width

		A	B	C	D
ENDLESS MULLION	FINISHED FRAME NET OPENING	55-1/4"	82-3/16"	109-1/8"	136-1/16"
FULL FLANGE	FINISHED FRAME NET OPENING	55-1/2"	82-7/16"	109-3/8"	136-5/16"

30" Door (Catalog Size) 29-7/8" Actual Door Width

		A	B	C	D
ENDLESS MULLION	FINISHED FRAME NET OPENING	62"	92-7/16"	122-7/8"	153-5/16"
FULL FLANGE	FINISHED FRAME NET OPENING	62-1/4"	92-11/16"	123-1/8"	153-9/16"

Model 100F/100NT/100PR Door Service & Installation

10. Models 100/100PR Standard Frame Net Opening Heights

1. Frame Height Data

	CATALOG DOOR HEIGHT			
	75"	73"	67"	63"
FINISHED FRAME	74-13/16"	72-13/16"	66-13/16"	64-9/16"
NET OPENING HEIGHT	75"	73"	67"	64-3/4"

2. Door Size

	CATALOG WIDTH			CATALOG HEIGHT			
	24"	26"	30"	75"	73"	67"	63"
ACTUAL SIZE	23-3/16"	26-3/8"	29-7/8"	73-1/16"	71-1/16"	65-1/16"	62-13/16"

11. Frame Installation Instructions Models 100F/100NT/100PR

1. Read instructions completely before installing frames.
2. Openings must conform to net openings listed in Price Book or other.
3. Check size of finished frame to net opening.
4. **Do not force frame into tight opening.**
5. Check net opening for plumb and square as shown below. Sill must be level left to right and front to back.
 - a. Jambs, header and sill should be wood for a secure installation.
 - b. Anthony door frame needs a sill of at least 1-1/2" for proper installation.

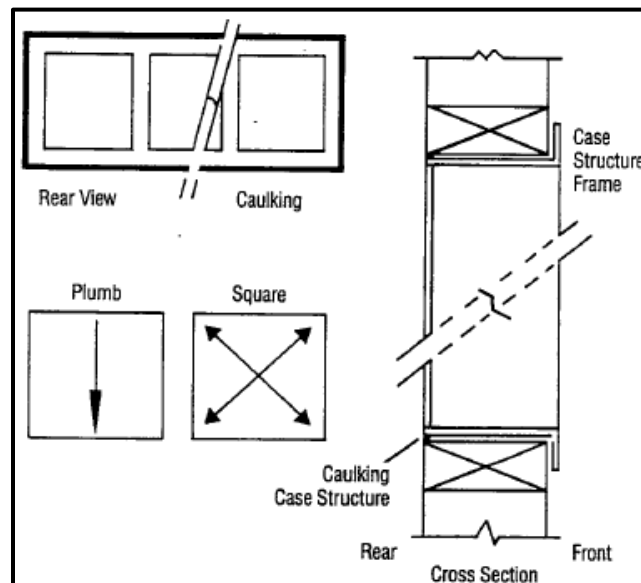

Frame Installation

6. Set frame in opening. For safety, partially install wood screws in top of frame. **Do not tighten.** Torquemaster (silver rectangular box) goes at bottom of frame. Hinge pin to top of frame.

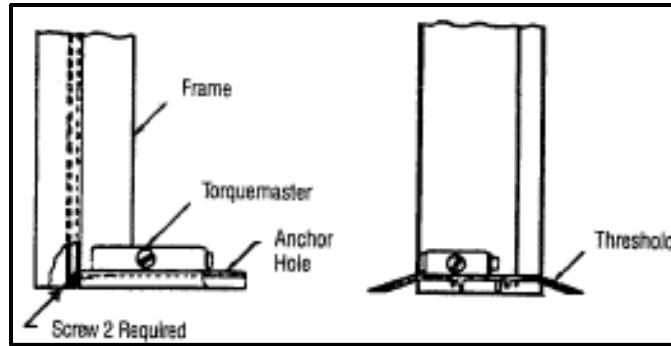

Pass-Thru Cross-Section (with/without Threshold)

7. Check frame for square as shown. Shim as necessary. Ensure that shims are placed as close to installation holes as possible. When shimming is necessary, shim top to bottom and/or left end of frame and right end of frame to maintain square of frame in net opening.
8. From the inside of case, **caulk all four sides of frame** between frame and case opening, as shown in *Frame Installation*.
9. Starting with frame sill, install mounting screws and tighten. Do sides next, then top. **(Do not over-tighten top screws as this will bow frame.)**
10. From inside the case, re-check caulking.

12. Hold-Open Replacement

1. Hold-Open Prior to 1987

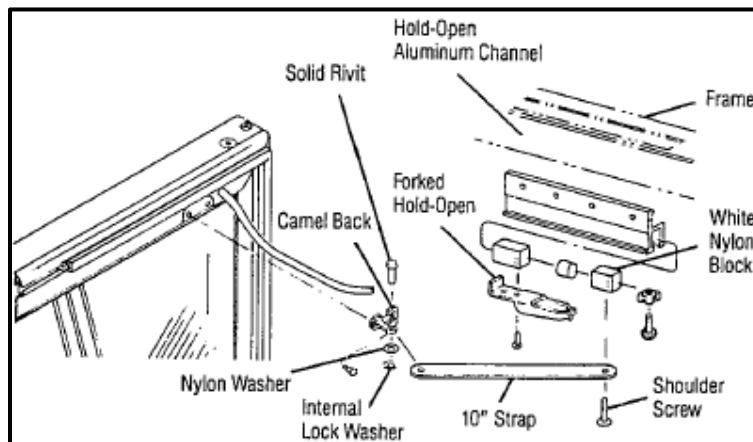

- a. To remove, insert flat-head screwdriver into shoulder screw on frame white slide block and remove. Go to back of door and remove locking washer and solid rivet. This will remove 10" door stop arm. To remove white block inside slide channel, remove end Phillips-head screw and slide block outside of channel. To remove fork, remove two (2) Phillips-head screws. To remove complete hold-open assembly, remove back of frame raceway for access to screws that hold hold-open channel to frame, and remove screws.
- b. Reverse instructions to replace.

Model 100F/100NT/100PR Door Service & Installation

2. Hold-Open 1987 to 1990

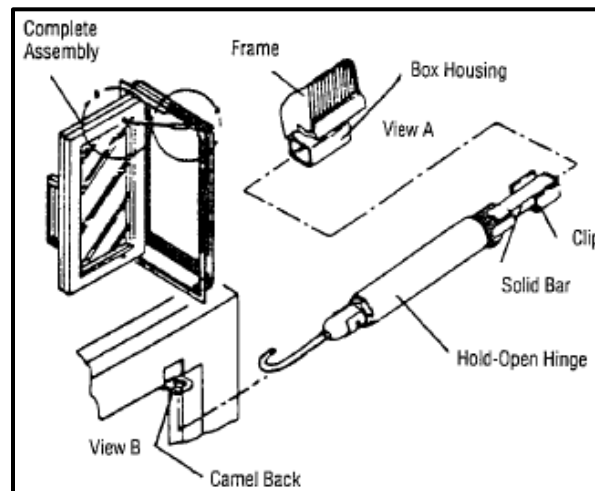

- a. Open the door and lock into hold-open position. Using a flat-head screwdriver, release the door stop and hold-open frame attachment from slide channel as shown.
 - b. Remove door stop and hold-open device from door.
- ### 3. Hold-Open 1990 to present

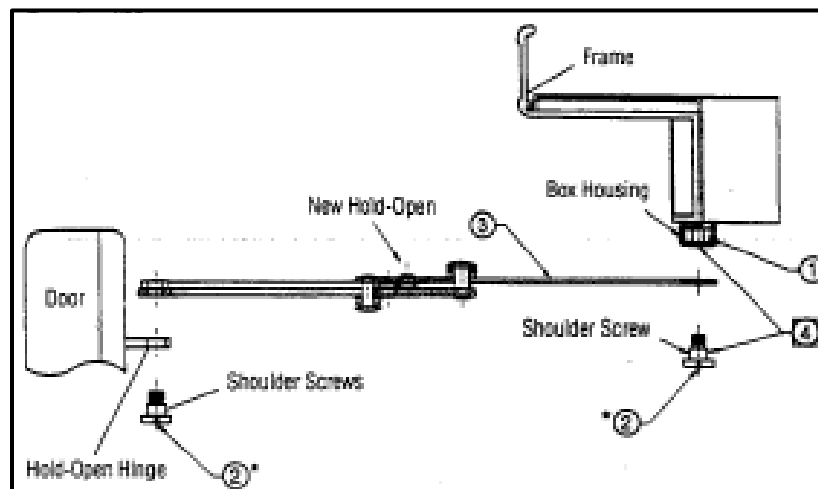

- a. Remove shoulder screws from both ends of slide stop arm with a flat-head screwdriver.
- b. Reverse instructions to replace.

Model 100F/100NT/100PR Door Service & Installation

4. Retrofit Hold-Open to Update Doors from 1987 to 1990

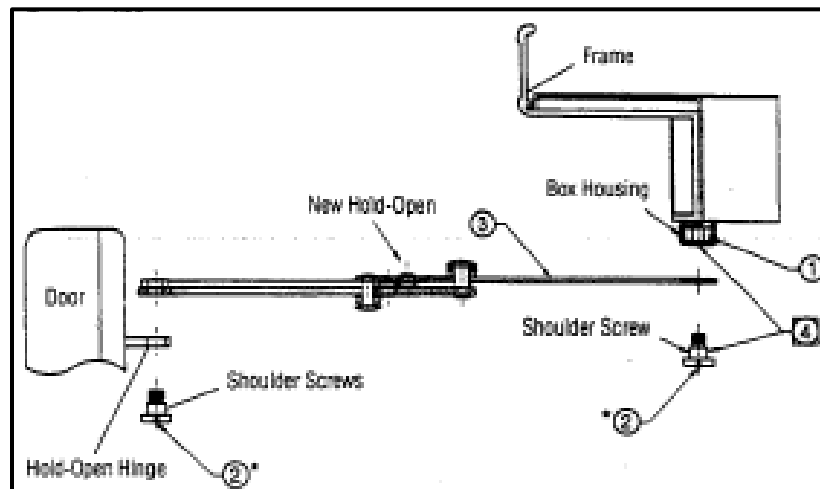

- a. Remove existing hold-open (see 12.1. & 12.2.).
- b. Using a 1/4" drill, enlarge hole for holding open hinge of door.
- c. Insert rectangular nut provided into hold-open hinge on frame, as shown.
- d. Mount new hold-open, as shown, with shoulder screws provided.
- e. Thin metal slide goes toward top of frame.
- f. **Do not over-tighten screws.** (Hand tighten with hand driver only.).

13. Reversible/Cordless Door & Hold-Open Installation

1. Align door with torque rod and insert into the Torquemaster socket at base of door.



2. Engage door with hinge pin plug inserted into hinge pin plug receptacle at top of frame.



Model 100F/100NT/100PR Door Service & Installation

3. Push door into top frame with thumb until hinge pin plug snaps into place.

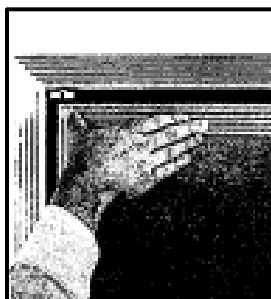

4. Hold-Open Instructions: (1987 to 1990)

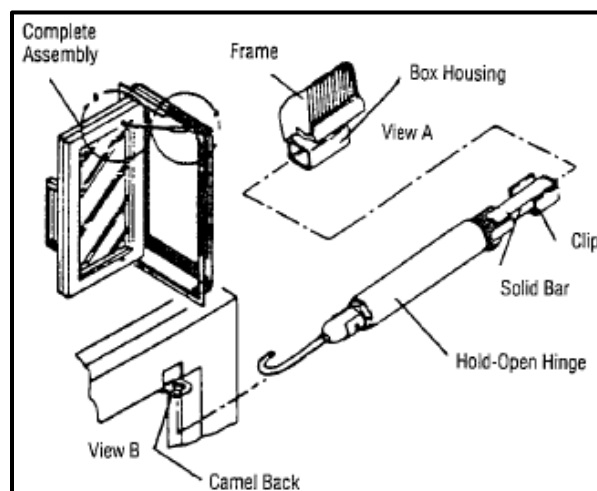

- a. Hook door stop and hold-open device into camel back side of door.
 - Note:** Change is for hook to be installed coming up from the underside of the camel back hinge.
- b. Slide hold-open bar with spring clip through box on frame until clip snaps into place.

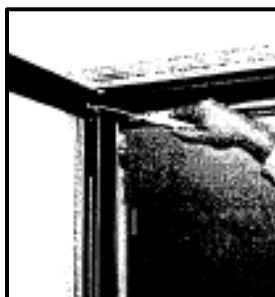

5. Hold-Open Instructions: (1990 to Present)

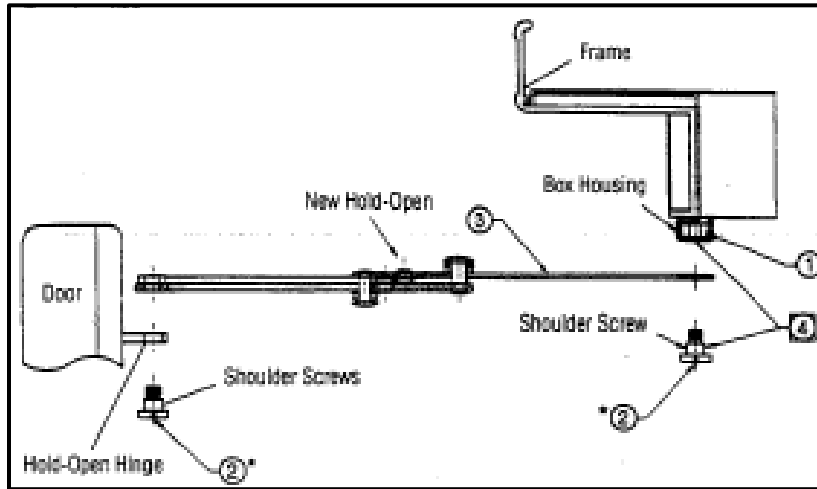

- a. Insert rectangular nut provided into hold-open hinge on frame as shown.
Note: On hold-opens starting March, 1990, the nut is affixed to hold-open arm.
- b. With shoulder screws provided, mount new hold-open as shown. Tighten screws.
- c. **Do not use power tools for installation or removal.**
- d. Install thin metal slide toward top of frame.

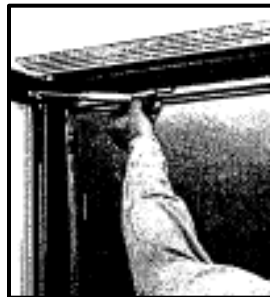

- 6. Adjust closing force by turning the screw on the front of the Torquemaster with a flat-head screwdriver. Turn counterclockwise to tighten, clockwise to loosen. **Do not over-adjust as this will cause door to slam.**

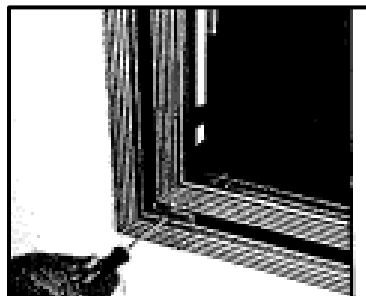

- 7. If necessary to square door in frame opening, turn end screw on Torquemaster (marked SAG ADJ) with a flat-head screwdriver.

Model 100F/100NT/100PR Door Service & Installation**14. Reversing Frame Hardware (1987 to Present)**

1. Remove Torquemaster by turning center screw counter-clockwise.

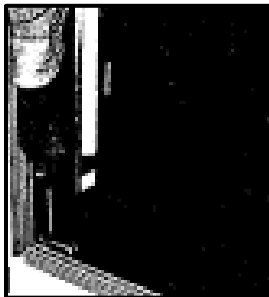

2. Remove back cover plate with a flat-head screwdriver and insert into old Torquemaster hole. Replace and re-install Torquemaster in new position.

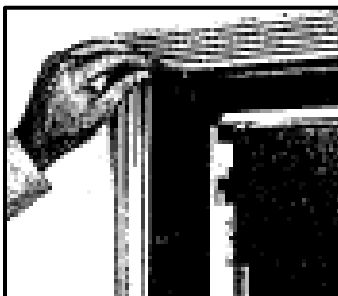

3. Insert black safety cover plate into opposite side hinge pin hole.

**15. Door Reversing Instructions (1987 to 1990)**

1. Release tension on Torquemaster by turning front screw on Torquemaster clockwise.

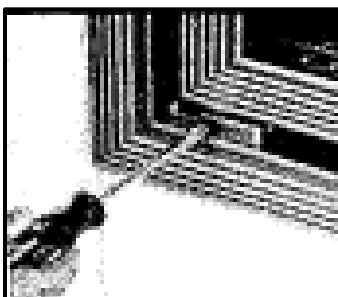

Model 100F/100NT/100PR Door Service & Installation

2. Hold Opens:

- a. (1987 to 1990): Open door and lock into hold-open position. Using a flat-head screwdriver, release the door stop and hold-open frame attachment from slide channel.
- b. (1990 to Present): Remove shoulder screw from camel back hinge on back of door.



3. Remove door stop and hold-open device from door.

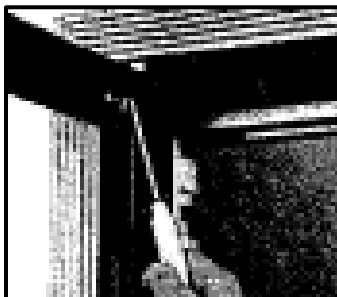

4. Remove hinge pin plug from frame by inserting needle-nose pliers into hinge pin plug 1/8" hole. Compress and pull hinge pin plug away from frame.

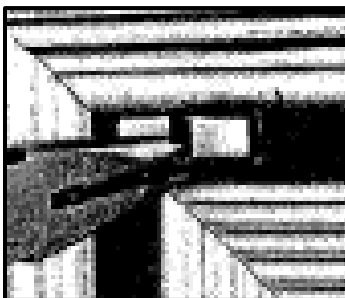

Model 100F/100NT/100PR Door Service & Installation

- Lift door out of Torquemaster. Lean door on its side, against a stable surface.

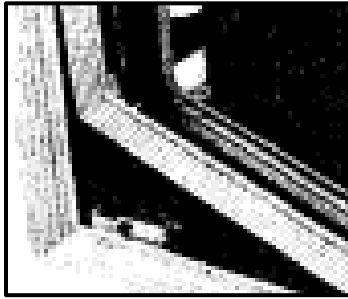

- Remove hinge pin plug access cover from hinge side of door.

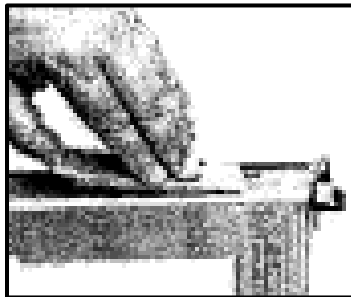

- Disengage safety snap from female plug, remove male plug from door and insert in opposite end of door.

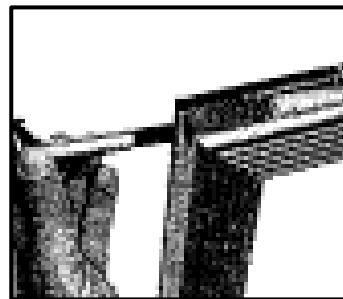
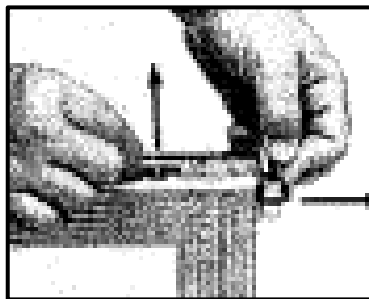

- Remove torque rod by sliding it out bottom of door, and insert it in opposite end of door.

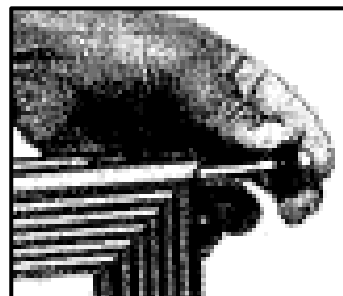
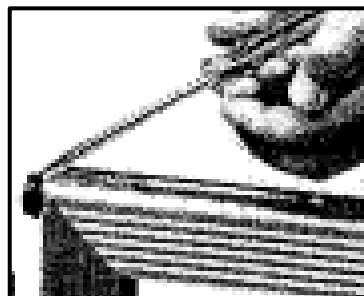

Model 100F/100NT/100PR Door Service & Installation

9. Carefully replace hinge pin plug access covers.

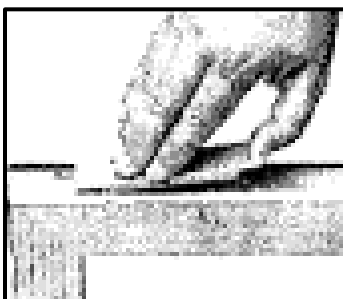

10. ***Do not use power tools for installation or removal.***

16. Door Reversing Instructions (1991 to Present)

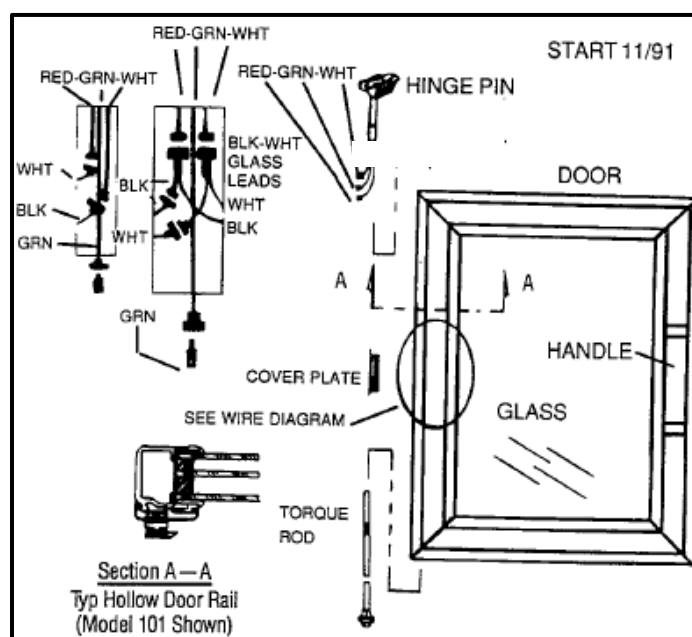

Door Quick Disconnect and Reversing

1. Reversing Door Hardware:
 - a. Remove cover plate from center hinge side of door.
 - b. Disconnect hinge pin connectors from door heater and/or glass heater connectors.
 - c. Pull hinge pin out through top of door.
 - d. Remove torque rod from bottom of door; pull rod down and out.
 - e. Insert torque rod in opposite end of door.
 - f. Insert hinge pin in opposite end of door.
 - g. Plug in hinge pin connectors to door heaters and/or glass heaters.

Model 100F/100NT/100PR Door Service & Installation

2. Wiring Instructions for Heated and Non-Heated Glass (see *Door Quick Disconnect and Reversing*)

Heated Glass:

- a. Connect Black or Red lead wire from hinge pin to black lead wire from glass, and Red or Black lead wire from door heater.
- b. Connect White heater lead wire from hinge pin to glass and door White lead wire.
- c. Connect Green/Yellow to ground.

Non-Heated Glass:

- a. Connect Black or Red lead wire from hinge pin to Black or Red door heater lead.
 - b. Connect White lead wire from hinge pin to White door heater lead.
 - c. Connect Green/Yellow to ground.
3. Replace hinge side cover plate.
 4. Re-install door.

17. Pass-Thru Installation

1. When threshold is desired, drill and lag on pre-drilled mounting holes only.



2. Install door. Refer to previous instructions on installation.
3. When door is in closed position, adjust floor wiper seal to fit flush with the floor or slab and screw into place.



Model 100F/100NT/100PR Door Service & Installation

4. For no threshold, pass-thru frames are equipped with a base plate and a floor anchor bolt.

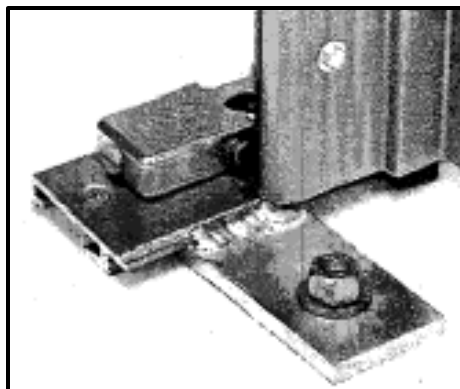

Base Plate

18. Pass-Thru Models

1. Model 125: Top 1/3 glass, Bottom 2/3 solid panel.
2. Model 127: All glass with Roll-A-Way unit.
3. Model 130: All glass or all solid panel.

19. Pass-Thru Frame Wiring Diagram

1. With Threshold.

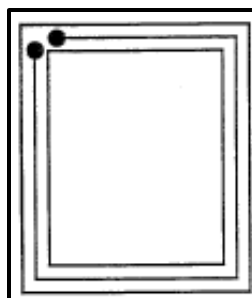

2. Without Threshold.

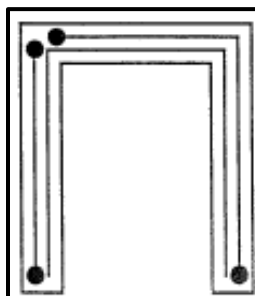

20. Frame Sill Plastic Protector Installation

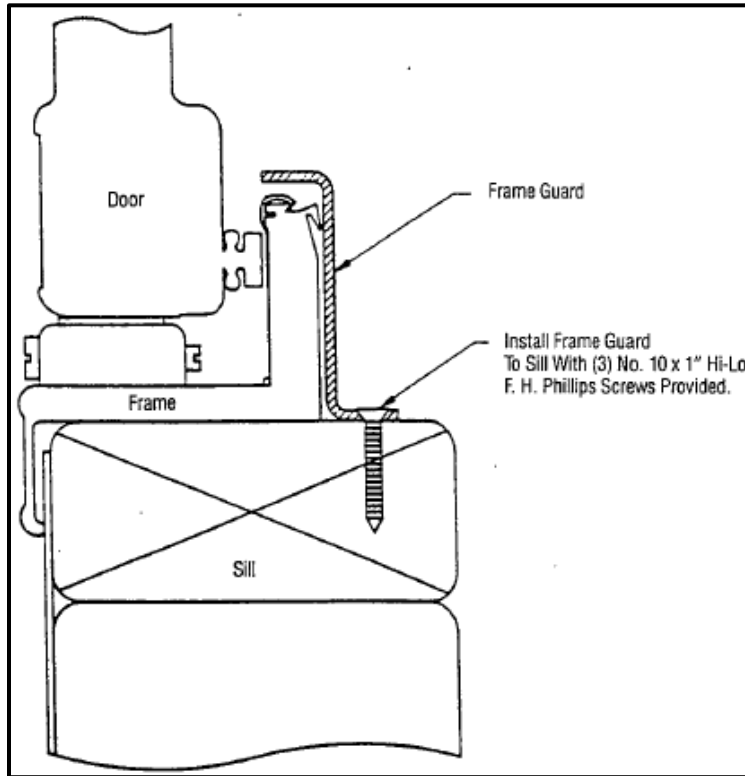

1. Set metal protector on sill inside of case, between clear opening of frame, with curved edge over bottom sill plastic.
2. Install protector on sill into pre-drilled holes, with the three (3) provided #10 x 1" Phillips screws.

21. Contact Plate and Contact Plate Retainer Replacement

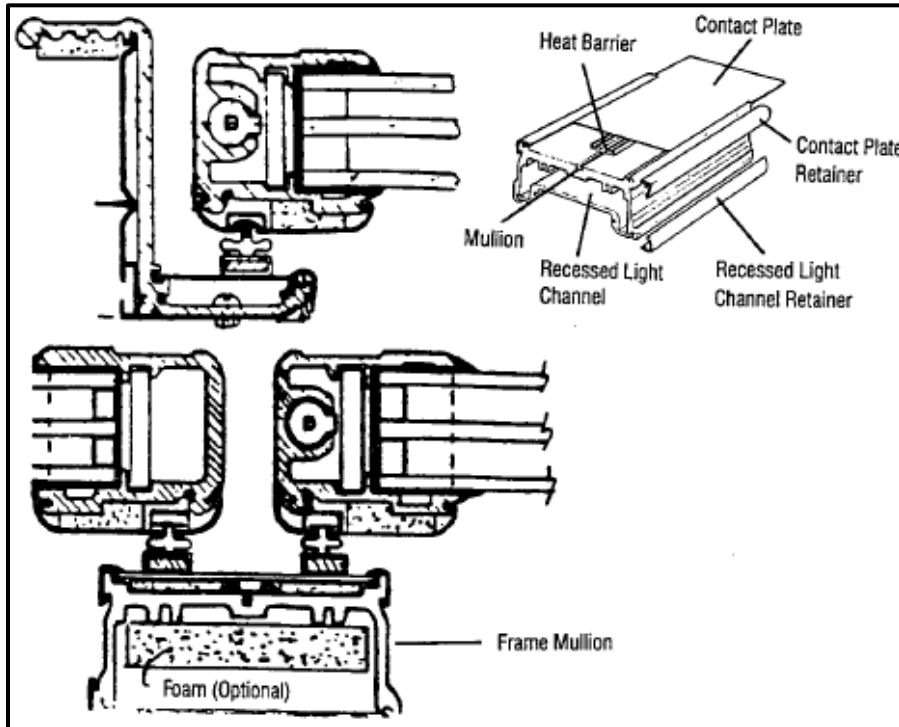

1. Remove door. Follow reversing the door instructions to remove the door.
2. To remove contact plate and contact plate retainer, insert flat-head screwdriver under side back edge of black plastic retainer and gently pull up to unsnap retainer from mullion and perimeter of frame. Remove contact plate. Frame heaters are now exposed.



3. To replace, lay contact plate flat on frame rail, insert top front leg edge of retainer between the contact plate and the mullion. Snap retainer on back edge of mullion and perimeter of frame. Remove contact plate. Repeat these instructions for complete frame.
4. Model 100FR and 100PR contact plates for pre-wired ballast frames are 3-7/16" wide; Model 100R contact plates for non-pre-wired frames are 2-1/2" wide.
5. All replacement parts are the same for Model 100R and 100FR, except the width of the mullion contact plate and the lights on the Models 100FR and 100PR, which are pre-wired.

22. Ordering Replacement Doors

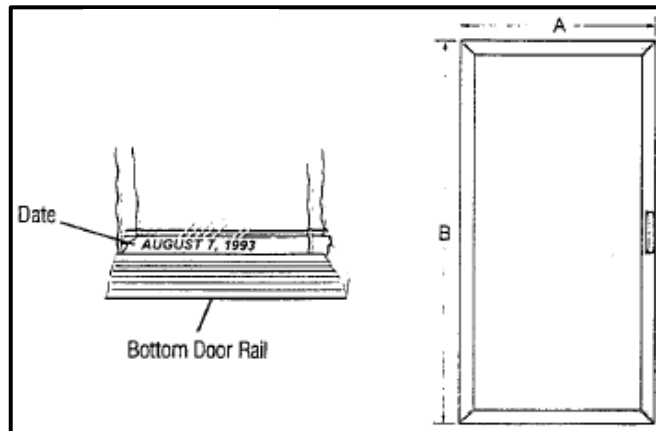

Replacement Doors (All Swing Door Models)

1. Specify outside dimensions of door (measure to nearest 1/16”).
2. With or without heaters?
3. Hinge swing; left or right?
4. Specify Model: Cooler or Freezer?
5. Specify finish.
6. Specify any custom items in the original order.
7. Specify date of original order and/or Anthony confirmation/invoice number. (Original manufacture date is stamped on metal spacer bar between panes of glass, as shown above.)
8. With or without locks?
9. Specify voltage.
10. **Pass-Thru Models 125, 127, 130:** With or without threshold?

23. Torquemaster and/or Casting Replacement

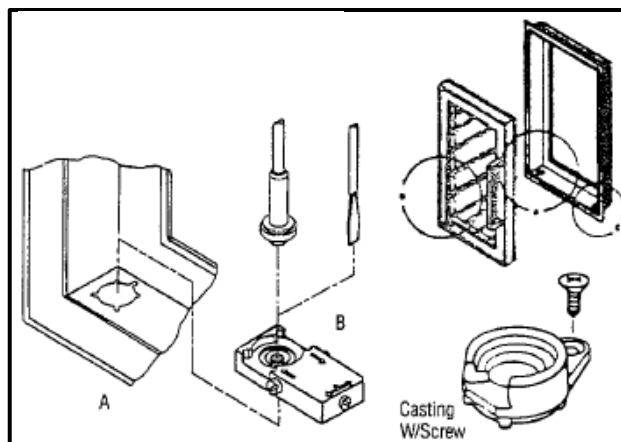

Torquemaster and Access Hole Cover Replacement

Model 100F/100NT/100PR Door Service & Installation

1. Since 1983, the Torquemaster has been used on all standard production doors.
2. To remove, insert flat-head screwdriver into top center cutout in Torquemaster and turn screw 1/8" turn. If necessary, insert small flat-head screwdriver between edge of Torquemaster and frame and gently pry up.
3. Reverse instructions to replace.
4. **Prior to 1983:** Remove single Phillips-head screw on back side of casting. Pull casting up to remove. Torquemaster and casting holes are the same, and interchangeable with the torque rod.

24. Door Gasket Replacement

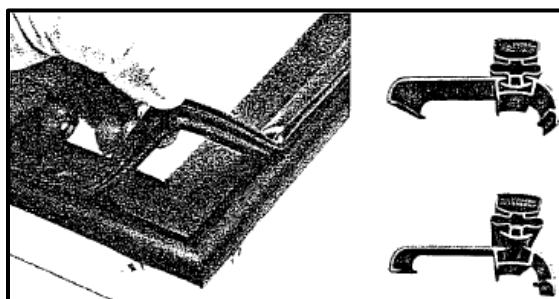

1. Remove old gasket by starting in corner, gently pulling gasket away from plastic.
2. To replace gasket, remove top and bottom door plastic and slide gasket up both sides of door. Slide top and bottom plastic onto gasket, then replace top and bottom plastic on door rail. Tuck in corners of gasket with flat-head screwdriver.

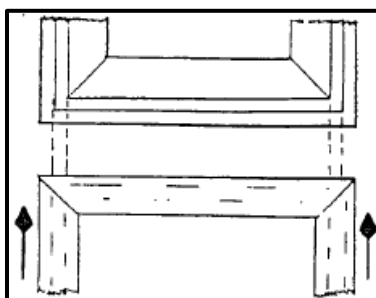

Model 100F/100NT/100PR Door Service & Installation

25. Door Plastic (Cover) Replacement

1. Starting in corner, gently pull rubber gasket away from door plastic.
2. With gasket removed, insert flat-head screwdriver under outside edge of plastic and gently pry up. At either end of plastic, run screwdriver the complete length and width of door rail. With outside edge of plastic released, push plastic toward glass to remove.

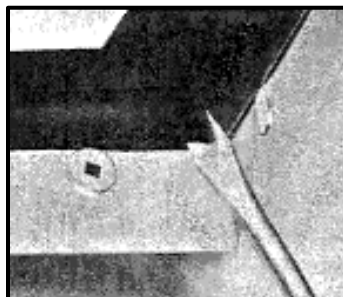

3. To replace, insert inside edge of plastic (closest to glass) into inside door rail groove. Snap outside edge of plastic over outside edge of door rail.

26. Door Handle Replacement

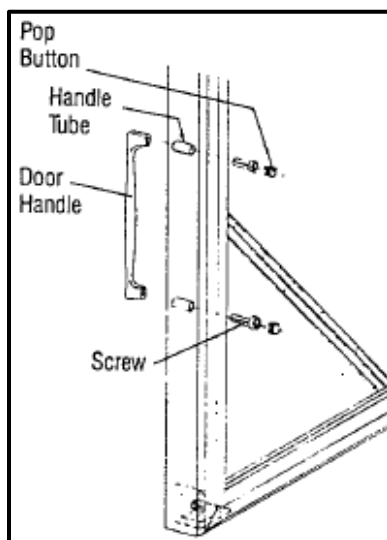

1. Remove plastic hole plug from back of door plastic.
2. Insert 5/32" wrench into access holes and remove screws.
3. Reverse instructions to replace handle.
4. Handle screws are contained in door frame.

Model 100F/100NT/100PR Door Service & Installation

27. Side Access Plate Replacement

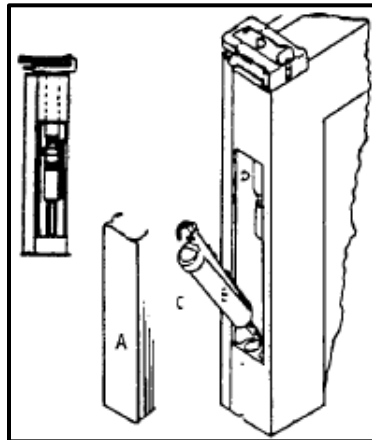

Hinge Pin and Cover Plate

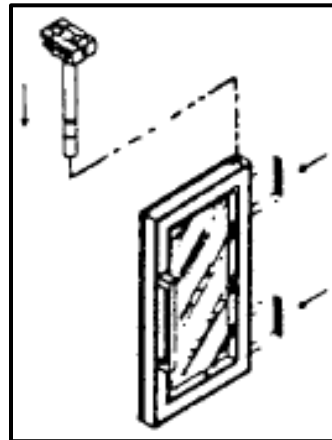

Hinge Pin Removal

1. **1987 to 1991:** To remove, insert flat-head screwdriver under top side of access plate and pull up.
2. **1991 to Present:** To remove, insert flat-head screwdriver under edge of center side of access plate and lift up.
3. To replace, snap plate(s) into door extrusion.

28. Door Female Plug Replacement (1987 to 1991)

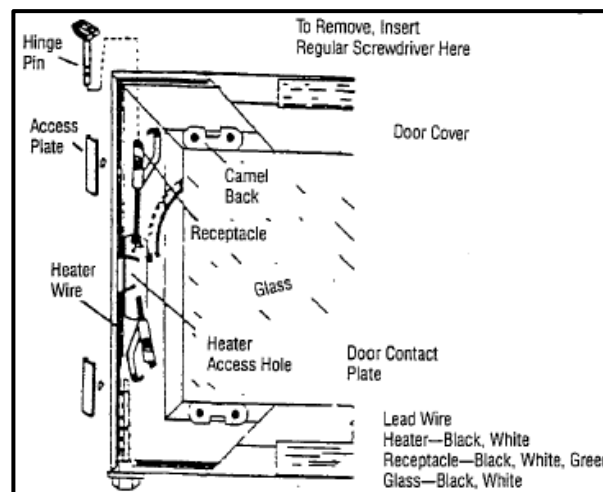

1. Gently insert flat-head screwdriver under edge of top side access plate and pull up to remove as in Side Access Plate Replacement.
2. Unsnap hinge pin from female receptacle.
3. Female plug is installed with additional lead wire. Pull female plug out through side access hole and cut Black, White and Green lead wires.
4. Reverse instructions to replace new female receptacle. Re-wire Black to Black, White to White and Green to ground.

Model 100F/100NT/100PR Door Service & Installation

29. Door Female Plug Replacement (1991 to Present)

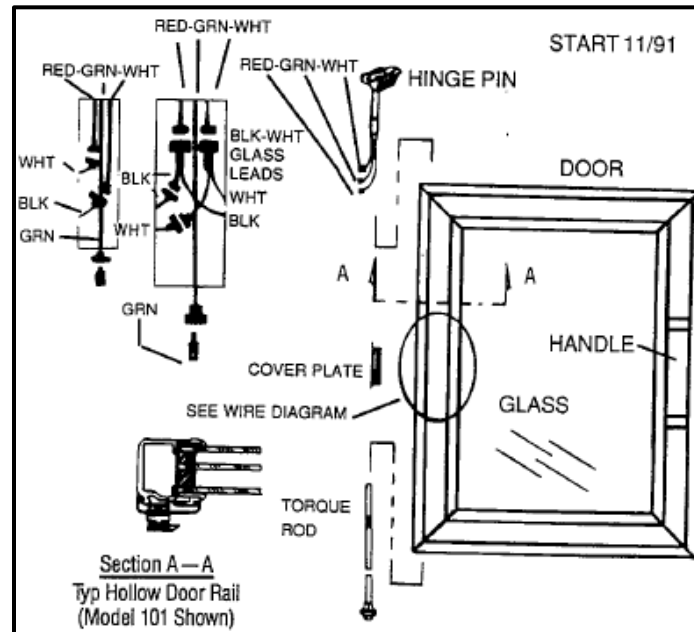

Door Quick Disconnect & Reversing

1. Remove center side access plate.
2. Unplug hinge pin from heater wire leads.
3. Pull molded hinge pin through top of door.
4. Reverse instructions to replace new female plug.

30. Frame Female Socket Replacement

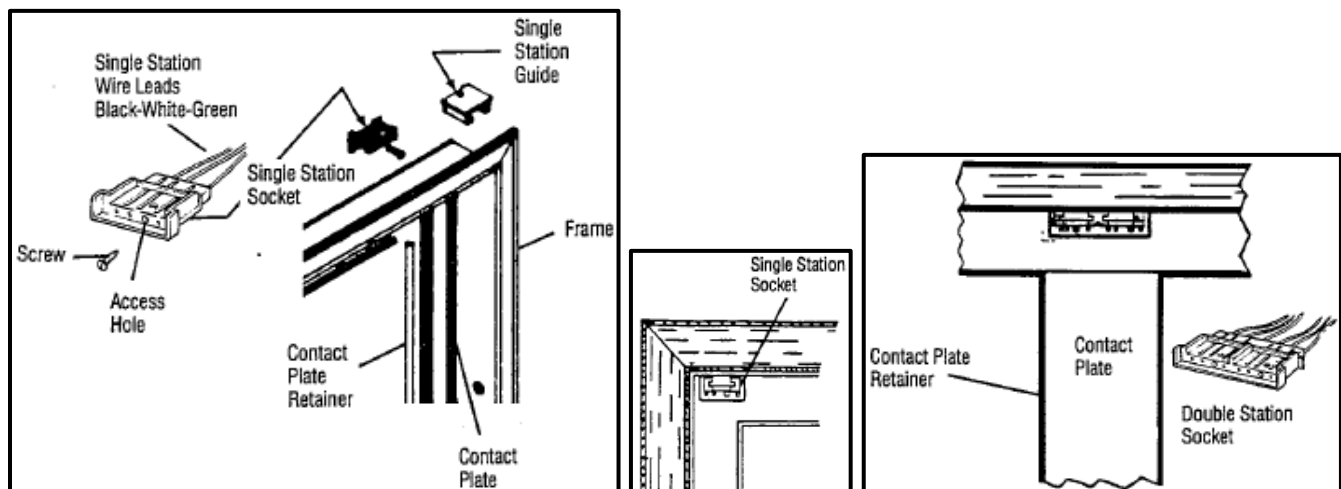

1. Frame female plug is removed through front side of frame.
2. Insert small Phillips-head screwdriver into round access hole in face of female plug and remove screw. For double station socket replacement, remove two (2) screws out through front.

Model 100F/100NT/100PR Door Service & Installation

3. Female plug has extra length wire leads in raceway for easy replacement.
4. Pull plug out front and cut lead wires: Black, White and Green/Yellow.
5. Reverse instructions to re-wire: Black to Black, White to White and Green/Yellow to ground.

31. Door Heater Replacement (1987 to 1991)

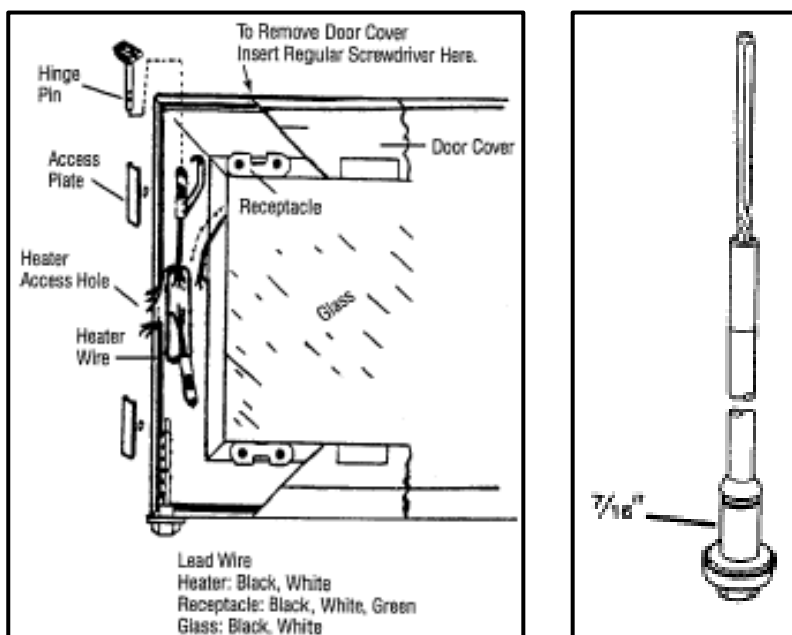

1. Remove door plastic.
2. Remove center side access plate.
3. Unsnap hinge pin from female receptacle.
4. Wiring for doors is done in the center back of hinge rail.
5. To remove heater, cut solid lead wires: Black, White and Green.
6. Heater wire lies in track on the back outside edge of door. Pull heater out.
7. If glass is heated, cut Black and White lead wires from glass.
8. Reverse instructions to replace heater wire. Wire Black to Black, White to White and Green to ground.

Note: If heated glass, reconnect glass Black and White lead wires to heater Black and White lead wires.

9. Reverse instructions to replace.

32. Door Heater Replacement (1991 to Present)

1. Remove door plastic.
2. Remove center side access plate (*Door Quick Disconnect and Reversing*).

Model 100F/100NT/100PR Door Service & Installation

3. To remove heater, unplug solid lead wires: Black, White and Green/Yellow (ground).
4. If glass is heated, unplug Black and White solid wires from glass.
5. Heater wire lies in track on the back outside edge of door. Pull heater out.
6. Reverse instructions to replace. Plug in Black or Red lead wire from hinge pin to Black or Red lead wire from heater, White lead wire from hinge pin to White heater lead and Green/Yellow lead from hinge pin to ground. If glass is heated, plug in Black and White lead wires coming off heater loom to Black and White lead wires from glass.
7. Replace side access plate.
8. Replace door plastic.

33. Hinge Pin Replacement (1987 to 1991)

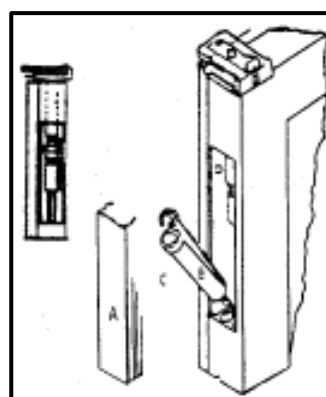
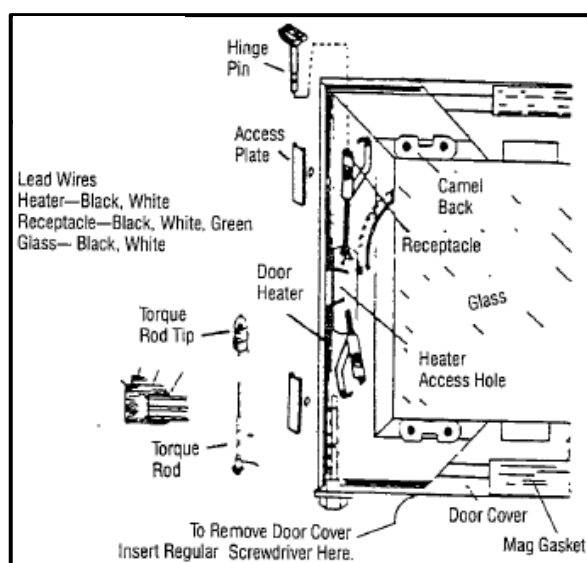

1. Remove top access plate.
2. Unsnap female receptacle from hinge pin and remove hinge pin through door rail.
3. Reverse instructions to replace.

34. Hinge Pin Replacement (1991 to Present)

1. Remove center hinge side access plate (*Door Quick Disconnect and Reversing*).
2. Unplug Black or Red lead wire from hinge pin from Black solid heater wire lead.
3. Unplug White lead wire from hinge pin from White solid heater wire lead.
4. Unplug Green/Yellow (ground) lead wire.
5. If glass is heated, unplug Black and White lead wire on heater loom from Black and White lead wire on glass.
6. Pull hinge pin out through top of door.
7. Reverse instructions to replace.

Model 100F/100NT/100PR Door Service & Installation**35. Wiring Instructions, Heated and Non-Heated Glass (1991 to Present)****1. Heated Glass:**

- a. Connect Black or Red lead wire from hinge pin to Black lead wire from glass and Red or Black lead from door heater (*Door Quick Disconnect and Reversing*).
- b. Connect White heater lead from hinge pin to glass White lead wire.
- c. Connect Green/Yellow to ground.

2. Non-Heated Glass:

- a. Connect Black or Red lead wire from hinge pin to Black or Red door heater lead.
 - b. Connect White heater lead from hinge pin to White door heater lead.
 - c. Connect Green/Yellow to ground.
3. Replace hinge side cover plate.
 4. Re-install door.

36. Torque Rod Replacement (1987 to 1991)

1. To remove torque rod, use flat-head screwdriver. Catch edge of torque rod shaft and tap rod down and out through bottom of door.
2. To replace, slide end of rod up hinge rail, then insert square shaft of torque rod into square hole in door rail. Tap into place.

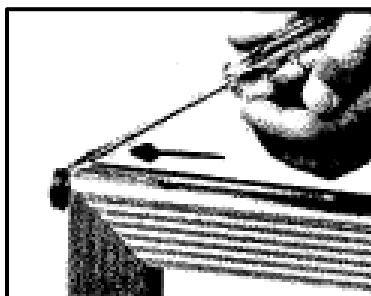
**3. *Torque rod has no tip.*****37. Torque Rod Replacement (1991 to Present)**

1. To remove torque rod, use flat-head screwdriver. Catch edge of torque rod shaft and tap rod down and out through bottom of door (see *Door Quick Disconnect and Reversing* illustration).
2. To replace, slide end of rod up hinge rail, then insert square shaft of torque rod into square hole in door rail. Tap into place.
3. ***Torque rod has no tip.***

Model 100F/100NT/100PR Door Service & Installation

38. Front Bumper Bar Field Installation

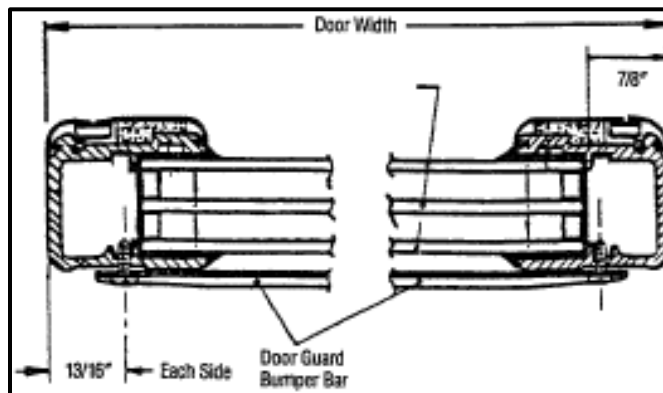

Front Bumper Bar

1. Order door guards 1" smaller than actual door width.
2. Specify finish (Gold/Silver).
3. Anthony provides pre-drilled screw holes in bar. Customer must drill a #30 or 1/8" hole in door rail 13/16" from each side of door rail.
4. Screws for mounting bar are self-tapping. **Screws are not to exceed 3/8" in length.**
5. Mount bar at desired vertical height to protect door glass.

39. Door Cylinder Lock Replacement or Repair

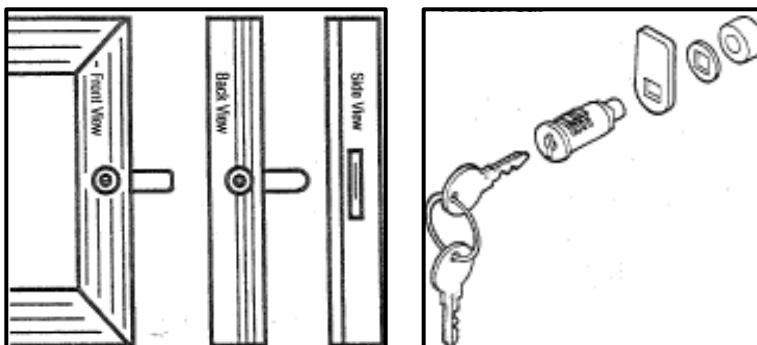

Cylinder Lock

1. If lock arm is bent or damaged, remove door plastic from back of door.

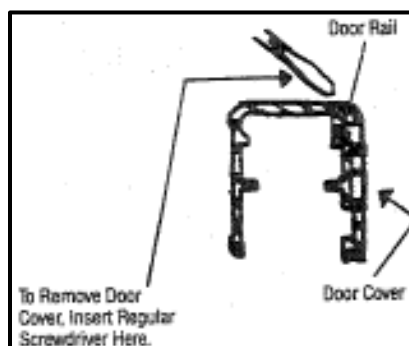

2. Insert Allen wrench in lock access hole and remove screw.

Model 100F/100NT/100PR Door Service & Installation

3. Pull washers out, then lock arm and replace.
4. If cylinder lock is defective, follow instruction #2 above. Insert key into lock and pull lock out through front of door.
5. Reverse instructions to replace.

40. P.O.M. Lock Installation

1. Remove dummy plug from hinge pin access plate on top of frame on handle side of door.

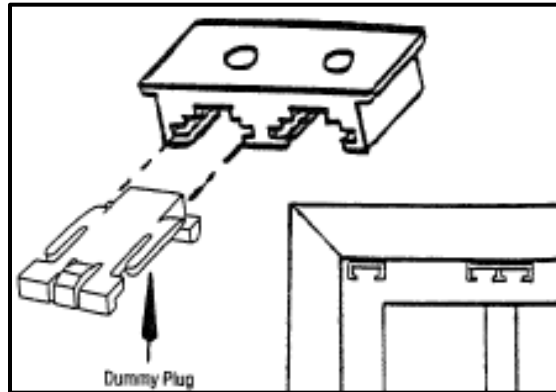

2. The P.O.M Lock inserts into a hinge pin access plate.

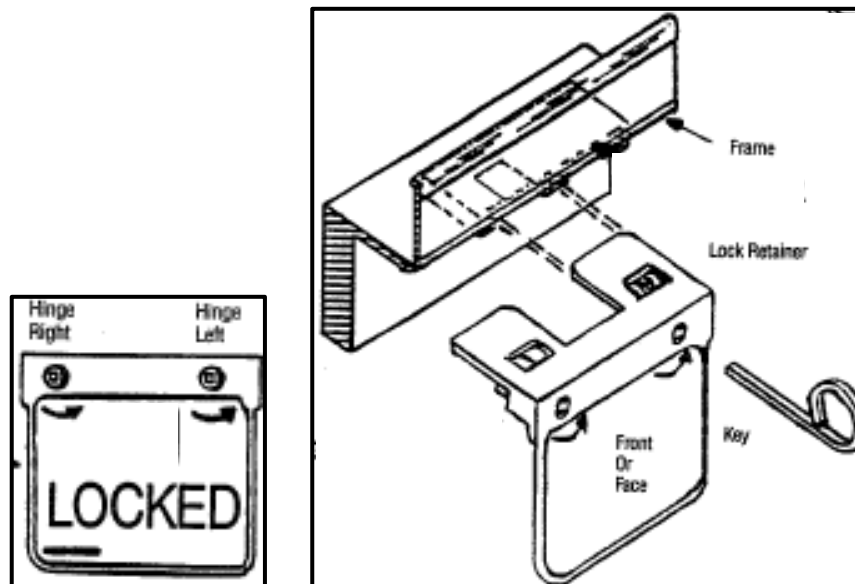

3. Insert key into P.O.M Lock square keyhole and turn key counterclockwise to lock.
4. Remove key.
5. To remove P.O.M. Lock, insert key into square hole and turn key clockwise.
6. To remove lock, pull lock straight out.
7. Replace dummy plug.

Model 100F/100NT/100PR Door Service & Installation

8. Lock only side that inserts into hinge pin access plate.
9. Facing the front of the P.O.M. Lock, the lock on the right side is for left-hinged doors and the lock on the left side is for right-hinged doors.
10. The P.O.M. Lock is manufactured to install in frame over the top of handle side of door.
11. For retrofitting the P.O.M. Lock on existing doors in the field, contact Anthony Customer Service or the local Sales Representative for information and instructions.

41. P.O.M. Lock Retrofit Installation

1. To install the retrofit retainer, measure in 1-1/2" from the edge of door (handle side) and mark frame above the door.

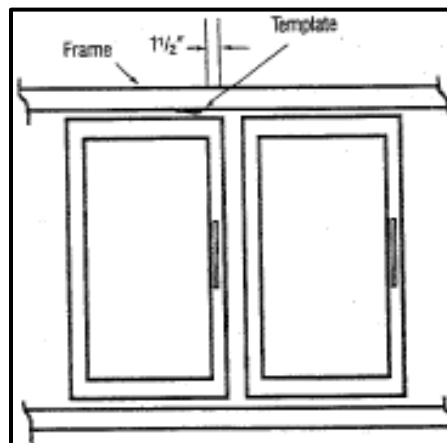

2. Place template provided on frame, with the right edge of the template on the mark previously made on the frame.

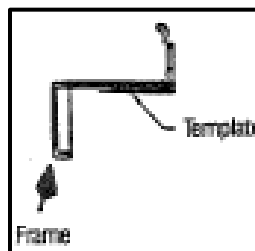

3. Mark the frame through the five (5) holes on the template with a pencil. Remove template and center punch the marks on the frame.
4. Drill the four (4) outboard holes with an 11/64" drill, the center hole with a 5/8" drill and deburr holes.
5. Place retrofit retainer bracket over the holes with the rectangular notch out. Use #10-32 x 5/16" screws provided and mount retainer bracket to frame.

6. Insert P.O.M. Lock into access plate and turn key to lock.

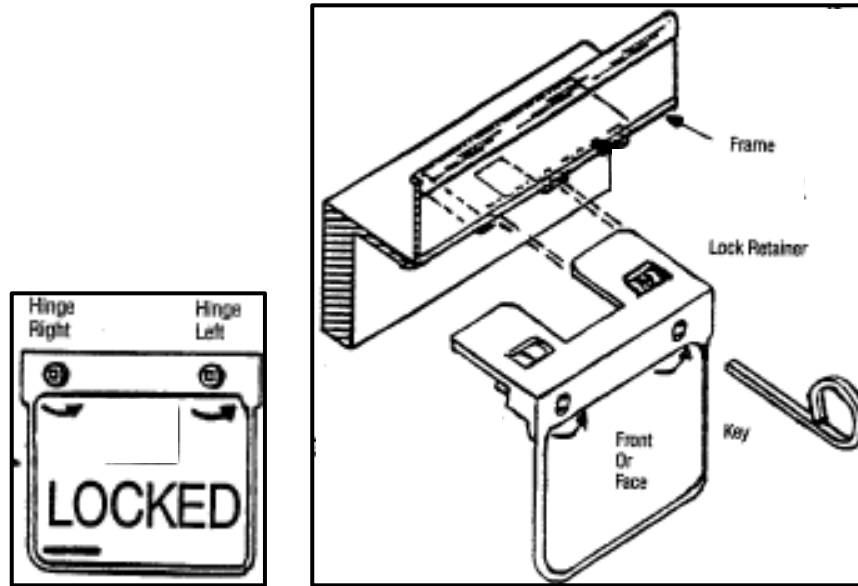

7. Remove key.

8. To remove P.O.M. Lock, insert key into square lock hole and turn the key clockwise.

42. Ordering Replacement Frames

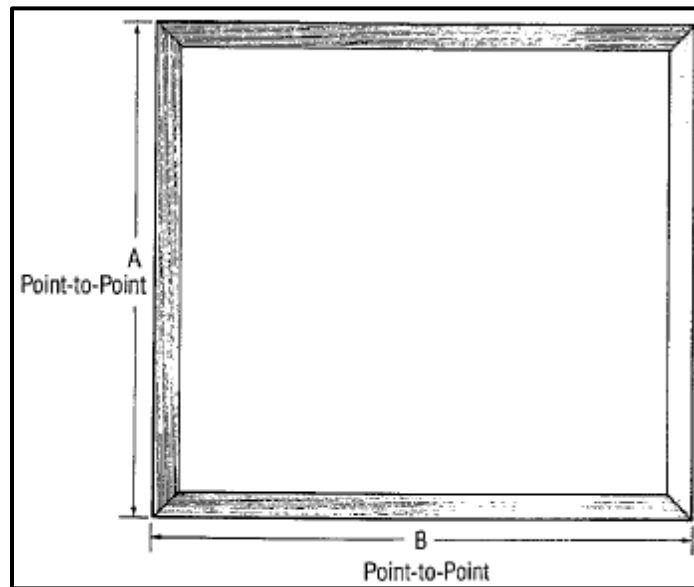

1. Specify outside point-to-point dimensions of frame. Measure to nearest 1/16".
2. Specify date of original manufacture and/or Anthony confirmation/invoice number. (Original manufacture date is stamped on metal spacer bar between panes of glass in doors.)
3. Specify Cooler or Freezer.
4. Specify door size width and height.

Model 100F/100NT/100PR Door Service & Installation

5. Specify finish (smooth/serrated, gold/silver/black, etc.).
6. With or without heaters?
7. With or without lights?
8. Specify any custom items on original order.
9. **Pass-Thru Models 125, 127, 130:** Specify with or without threshold.

43. Glass Replacement (Reglazing)

1. To remove torque rod from door, drive tapered shaft of torque rod from door.

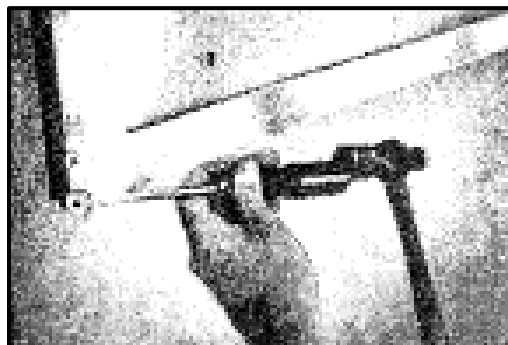

2. Starting at corner of door, remove gasket and plastic from all four (4) sides of door.

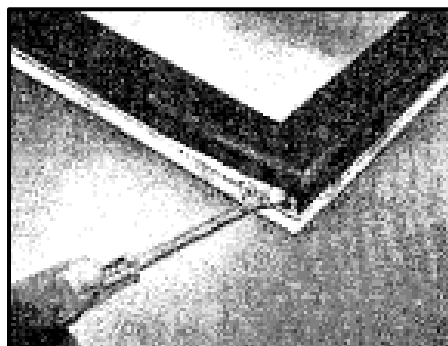

3. For models prior to 1987, unscrew SJ cord retainer to expose heating element wires. For models after 1987, remove top or center access plate. Unsnap hinge pin from female socket and remove, or unplug hinge pin lead wires to remove hinge pin. If heated glass is used, cut Black and White lead wires to glass. Remove heating element from door.

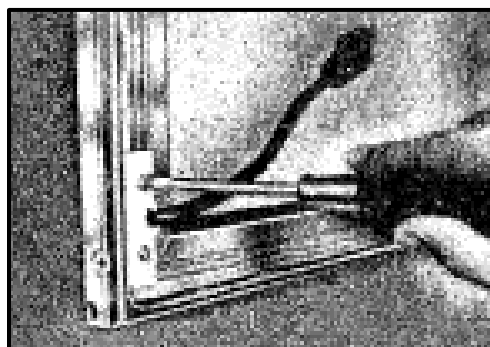

Model 100F/100NT/100PR Door Service & Installation

- Using a square-head or clutch-head driver, remove screws on both side rails only. Remove top and bottom door rails first.



- Drive rails from glass, using mallet and block, always starting at corner of door.



- Once rails have been removed from glass, re-insert new friction-fit glazing channel on new glass and drive rails onto glass.



- After both long rails have been affixed to glass, re-insert friction-fit glazing channel on top and bottom and tighten miters with square-head or clutch-head driver.



Glazing Channel

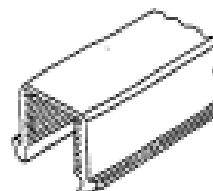

Square Head Screw



Clutch Head Screw



Model 100F/100NT/100PR Door Service & Installation

- When all four (4) door rails have been affixed to glass, measure diagonally to make sure door is in square.

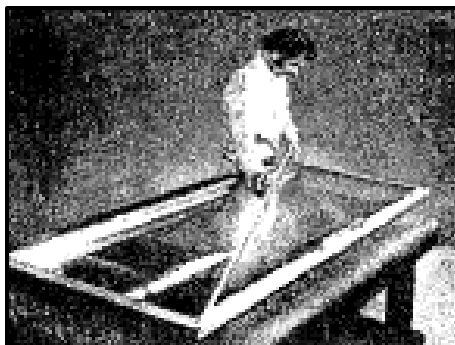

- After replacing the glass unit, and when door rails are in square, re-insert heater wires in door rail channels and repeat process. Replace gasket and retainer strips. For other door models, plastic replacement only may be necessary.
- To re-install torque rod, align torque shaft with key way in door and drive tapered shaft flush with bottom of door rail. On different door models, torque rods may vary. Some will have no tip, but the installation is the same. Insert rod through bottom of door rail.

Note: If heated glass is used, when disassembling door, cut Black and White lead wires to glass. When rebuilding door, pull glass heater leads out through heater access hole before assembling top or side door rails. Re-connect Black and White leads to heater wire Black and White leads. On newer models, re-connect hinge pin to heater receptacle or heater lead wires.

44. Humastat Installation Procedure

- Install Humastat Power Junction Box before refrigerator door power wiring, on the inside wall of refrigerator.

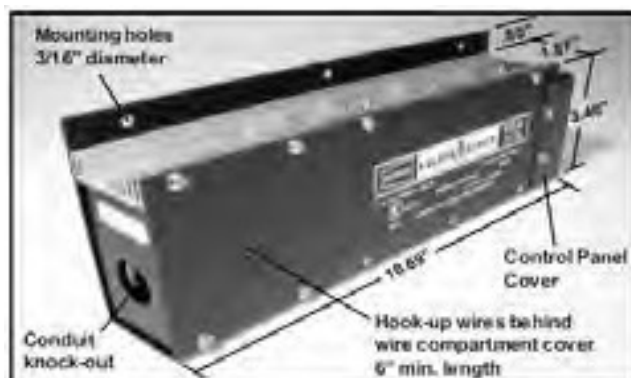

- Remove wiring compartment covers by removing four (4) sheet metal screws.

Model 100F/100NT/100PR Door Service & Installation

3. Connect heater hot wire to Red wire from control unit.

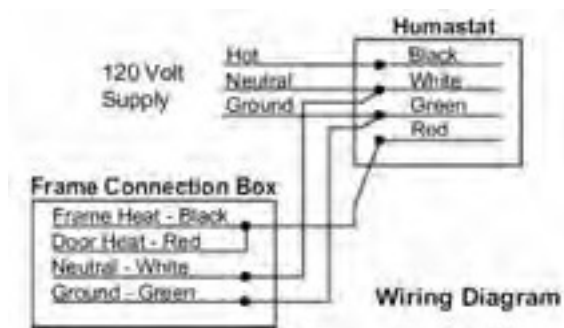

4. Connect input power hot wire to Black wire from control unit.
5. Connect all White wires, including common side of power line, line load and control unit White wire.
6. Connect Green Ground wire from control unit to Green Ground wire at frame and to incoming Ground wire (if furnished).
7. Replace the Wiring Compartment Cover with the sheet metal removed in #2 above.
8. Install Humastat Sensor on the outside wall of refrigerator above the door frame, within three feet of power junction box.

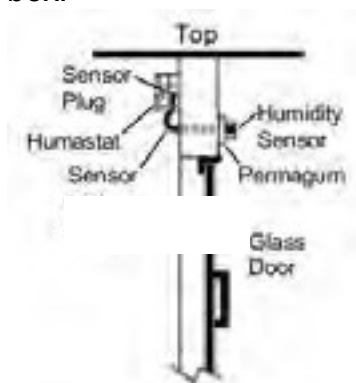

120 VAC 50/60 Hz, 20 Amperes Maximum

- a. Drill a 1/4" diameter hole through refrigerator wall directly above the door frame.
- b. Use the wood probe supplied with the sensor to feed the sensor wire through the refrigerator wall.

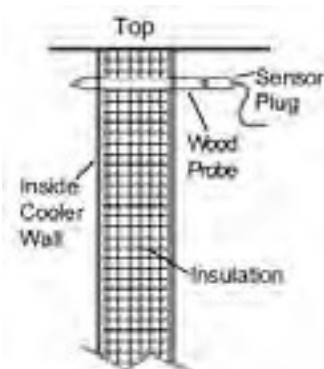

Model 100F/100NT/100PR Door Service & Installation

- c. Apply permagum to back of sensor around the wire. Pull the wire through the hole until the sensor makes close contact with the wall and secure it to the wall with the screws provided Seal the probe wire with the permagum on inside of wall.
9. Remove wood probe from sensor connector by holding the body of connector securely and pulling off the probe.
10. Insert the sensor plug into the sensor jack on the outside end of the power junction box.
11. Set the heater control knob for the lowest value which keeps the door free of undesirable moisture.
12. Red light indicates when heaters are functioning.

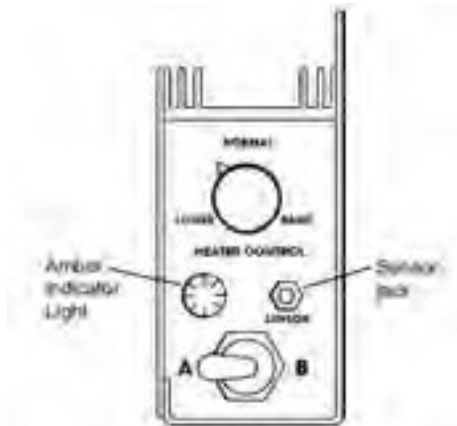

Control Panel End View
Switch shall remain in Position "A" for normal operation

45. Model 100FR Humastat

1. For Low Temperature applications, see sensor Part #F-161.
2. For Normal Temperature applications, see sensor Part #F-1649.
3. Sensor is pre-wired in frame mullion.

46. Frame Heater Wire Replacement

1. Remove door from frame, following previous instructions for door removal.
2. Insert small flat-head screwdriver under back edge of contact plate retainer and lift up to remove.

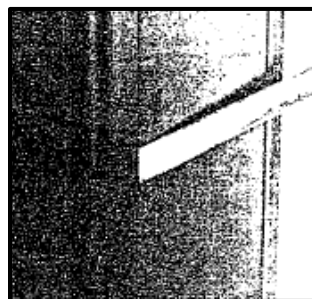

Model 100F/100NT/100PR Door Service & Installation

- Remove contact plate to expose heaters.

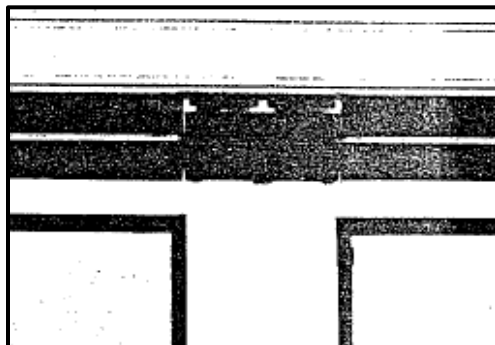

- See following frame and heater schematics.
- Cut heater lead wire and pull heater out of track.

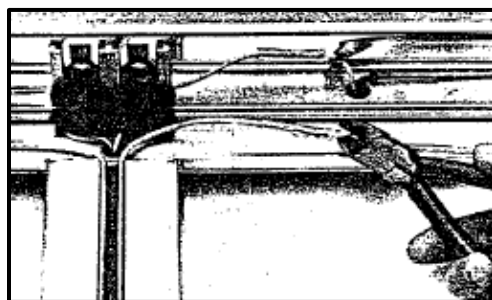

- When ordering replacement heaters, specify which heater needs replacing: top, bottom, end or center mullion. This will vary depending upon the particular frame make-up.
- Reverse instructions to re-install heater.

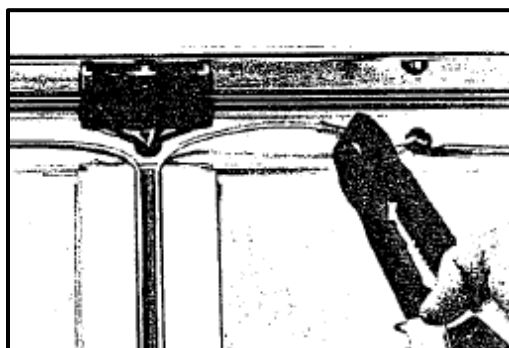

47. Frame Heater Wiring Diagram Model 100PR (Reversible) Low Temp

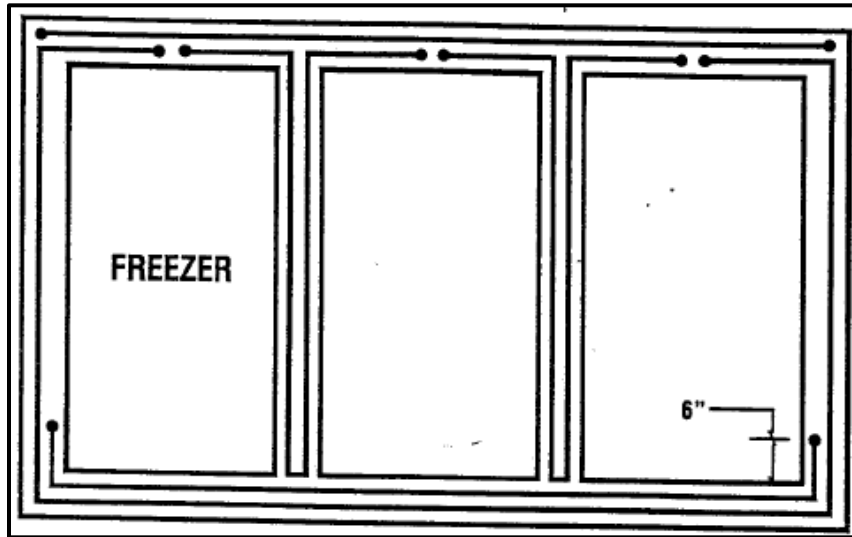

3-Door Frame (Typical for 2 thru 6 Doors)

1. Heater wire layout: Bottom and End – Perimeter – Center Top Supplement – Bottom Supplement.
2. Top heater to be installed before door sockets are set in place.

48. Frame Heater Wiring Diagram Model 100PR (Reversible) Normal Temp

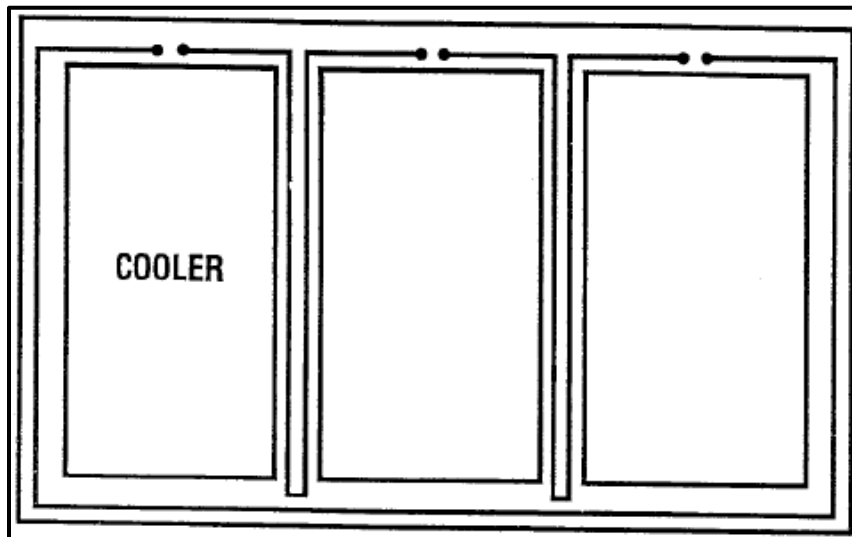

3-Door Frame (Typical for 2 thru 6 Doors)

1. Heater wire layout: Bottom and End – Perimeter and Center.

Model 100F/100NT/100PR Door Service & Installation

49. Model 100 Shelf Assembly Catalog Size/Shelf Size

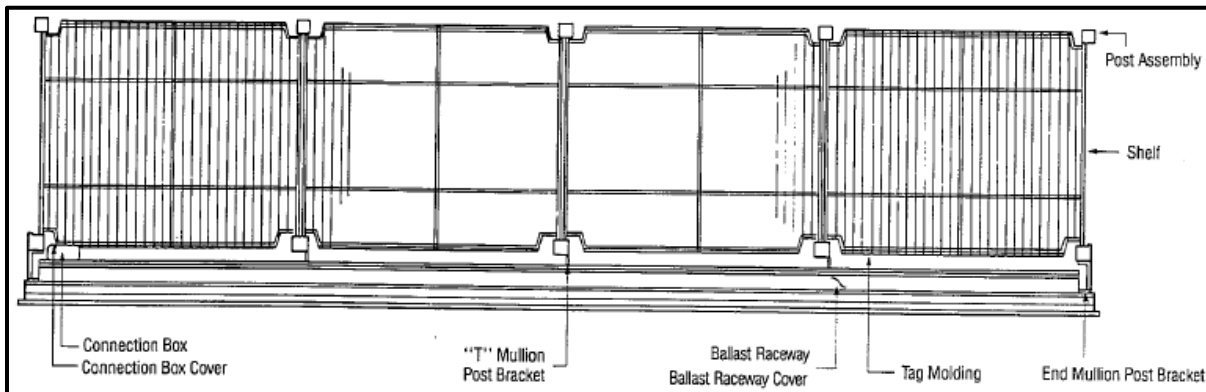
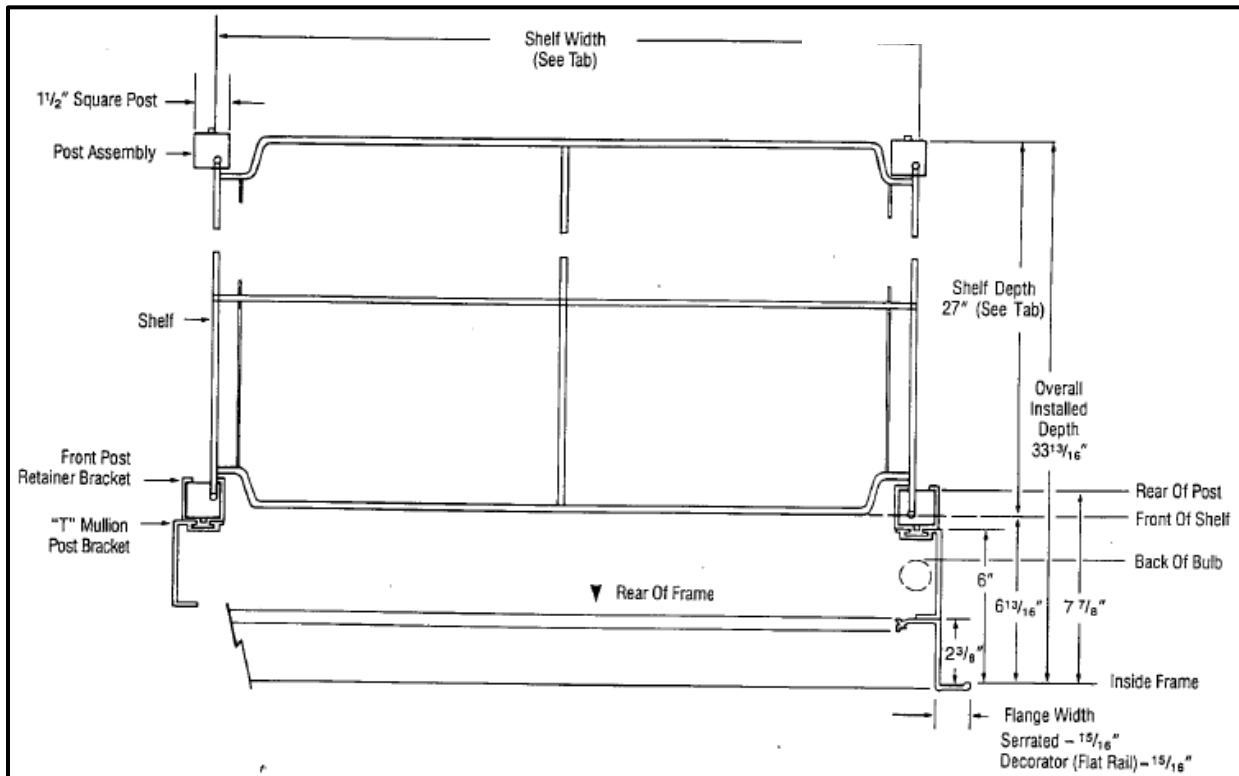

CATALOG DOOR SIZE	SHELF SIZE
24"	23-5/16" x 27"
26"	26-5/16" x 27"
30"	29-13/16" x 27"

Note: For 24" 1- and 2-Door Frames use shelf size 22-9/16" x 27". For three (3) Doors or more, use shelf size 23-5/16" x 27"

50. Shelving Installation Instructions (Prior to 1984)

1. Insert shelf over saw-tooth edges on back of front post.
2. Insert clip on back of shelf over back of rear post grooves.

Model 100F/100NT/100PR Door Service & Installation

3. Level rear posts.
4. Protector channels must be cut to desired lengths after shelving has been positioned. Protector channels snap over vertical shelf standards.

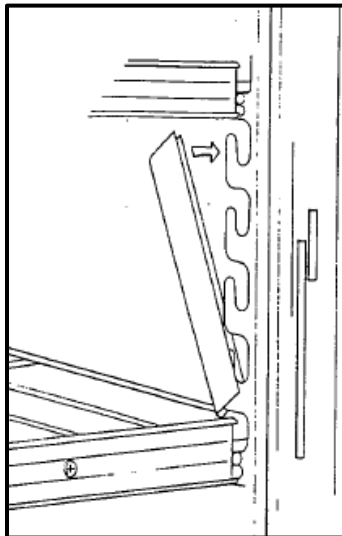

5. See shelf installation.

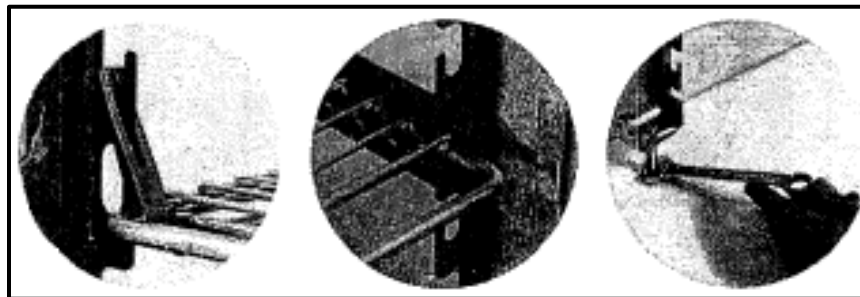

6. See Front Post and front light channel

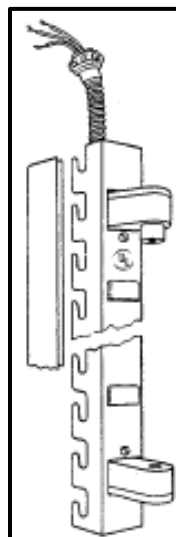

Front & Rear Post Safety Cover

Model 100F/100NT/100PR Door Service & Installation

7. See Rear Post.

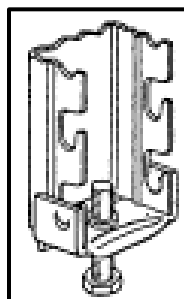

Rear Post w/Adjustment Bolt & Bracket

8. See Replacement Shelving

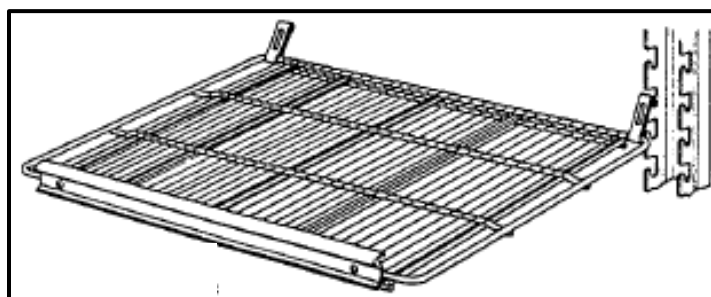

26" Deep Shelf	Part #
22-3/4" x 26	S-4031A
26-1/2" x 26	S-4031B
28-1/2" x 26	S-4031C
30" x 26	S-4031D
(Specify Tag: Gold-Silver)	

9. See metal tag molding clip and rear shelf clip.

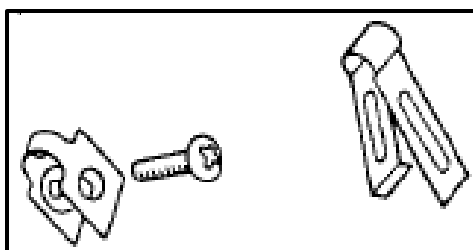

51. Four-Post Stabilizer Bar Installation

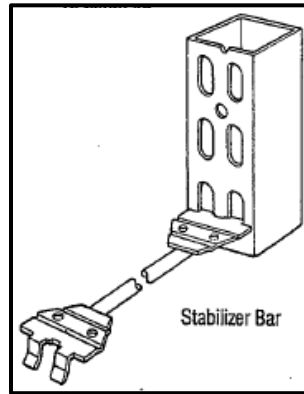

1. The four-post stabilizer bar is designed to help support the posts during installation and stabilize the system while in use.

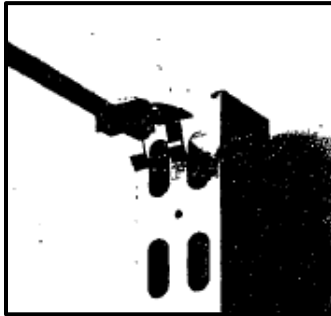

2. Insert the forked end of stabilizer bar into the elongated holes in post.

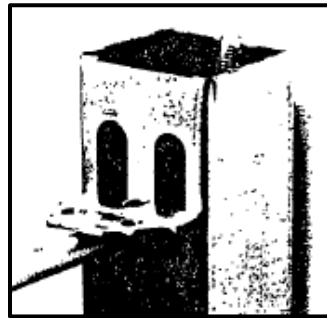

3. Install the post stabilizers on top and bottom of all posts, front to rear, before installing shelves.

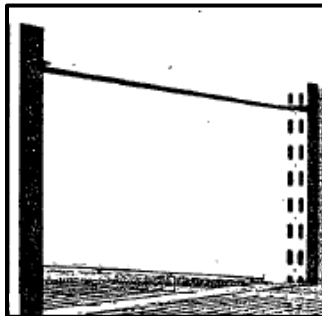

Model 100F/100NT/100PR Door Service & Installation

52. Four-Post Shelving System Installation (After 1984)

1. Attach post to inside frame by inserting post key into frame retaining bracket.

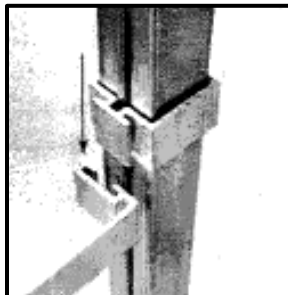

2. Before installing shelves, adjust all four posts to equal heights with leg leveling bolts at bottom of posts.



3. Insert front of shelf into front post at angle, then position rear shelf posts.

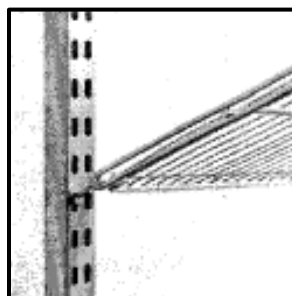

4. Drop rear of shelf down and pull back in slot on rear posts. Continue to add shelves behind each door, spacing for desired product merchandising.

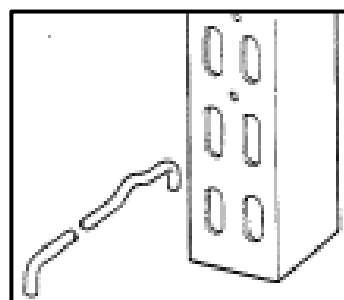
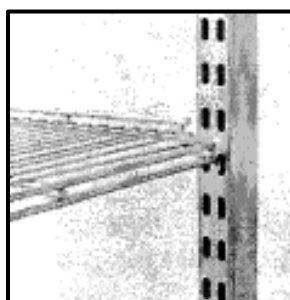

Side Product Stop

Model 100F/100NT/100PR Door Service & Installation

5. After installing shelves, adjust rear post leveling bolts to level. The Four-Post Shelving System is now ready for merchandising.

**53. Plastic Tag Molding Installation**

1. Tag molding is the exact length of the shelf's upper front bar. Center tag molding on front of shelf. Hook bottom of tag molding under shelf across entire width of shelf. Spread thumbs across tag molding and push up.

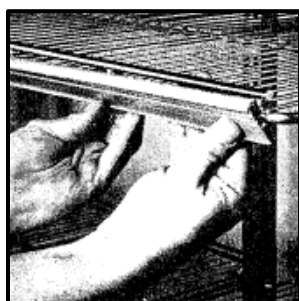

2. Snap top corner of tag molding strip onto shelf front. Apply even pressure across top of tag molding as it is fed onto top horizontal bar on shelf front.

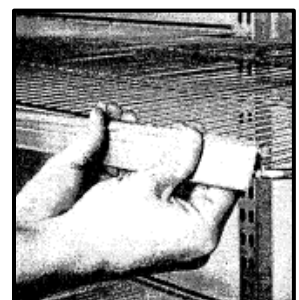

3. For replacement tag molding, specify width of shelf when ordering.

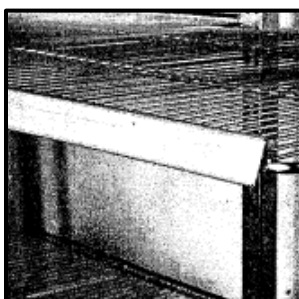

Model 100F/100NT/100PR Door Service & Installation

54. Model 100PR Low Temp 120 Volt Ballast & Lamp Wiring Diagram – Pre-Wired 1-Light System (1987 to Present)

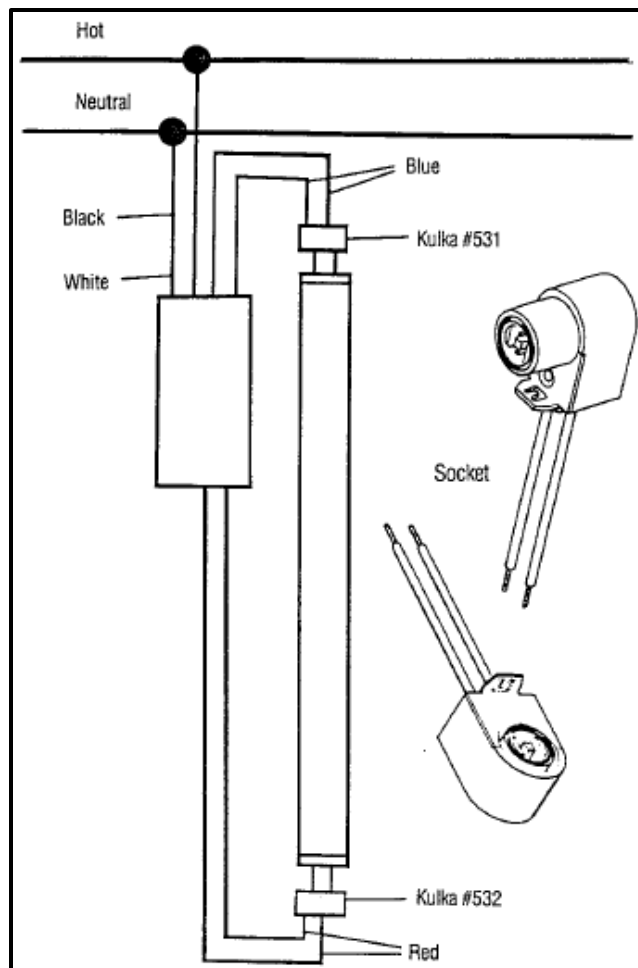

1. **Wiring:** Ballast has two (2) Red wires, two (2) Blue wires, a Black wire and a White wire.
 - a. Wire two (2) Red wires to two (2) Red wires on bottom socket.
 - b. Wire two (2) Blue wires to two (2) Blue wires on top socket.
 - c. Black wire goes to HOT; White wire goes to NEUTRAL.
2. **To replace lamps:** Lift lamp up and out.

Model 100F/100NT/100PR Door Service & Installation

3. **To replace sockets:** Remove bulb, then pull top socket down and out. To replace bottom socket, pull up and out. Extra lead wire is in the mullion. Pull socket out and cut lead wires. To replace, re-wire new socket. To replace socket, insert tab on bottom of socket "D" hole in light channel. Lift up for top socket and push down for bottom socket. To replace lamp, lift lamp up into top socket, then down into bottom socket.

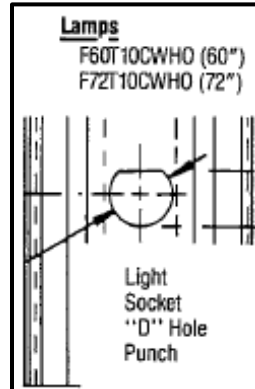

55. Model 100PR Ballast Replacement

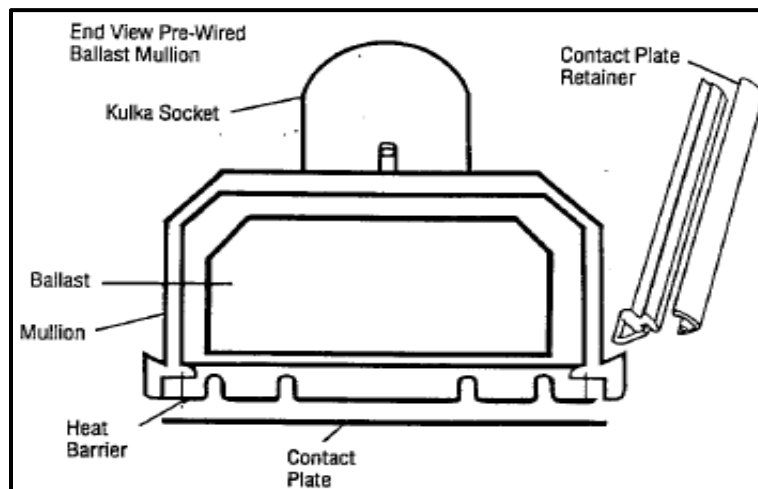

1. Remove door from frame opening.
2. Insert flat-head screwdriver under back edge of contact plate retainer to remove.
3. Remove contact plate from mullion.
4. Pull heat barrier from mullion to remove.
5. The ballast has a wiring diagram on its face. To replace ballast, cut lead wires: two (2) Red, two (2) blue, one (1) Black and one (1) White. Remove ballast. **For replacement ballast, always use ballast number from existing ballast.**
6. Reverse instructions to replace ballast, heat barrier, contact plate and contact plate retainer.

Note: When the two (2) Blue wires and the two (2) Red wires are connected to the top and bottom socket, make sure the wiring is one to one. **Do not gang wire.**

56. Lamp Replacement

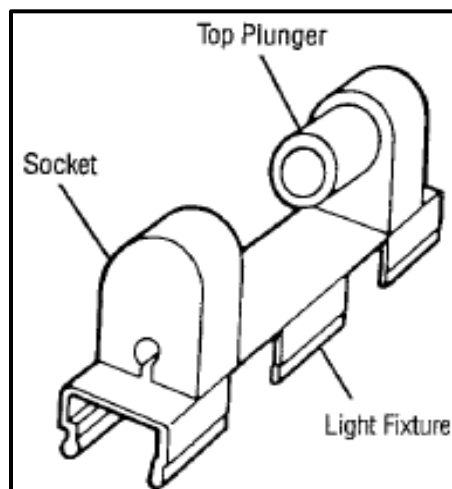

1. Lift lamp up into top plunger socket and then out at bottom to remove.
2. Pull end caps off end of light shield, then remove bulb from shield.
3. To replace bulb, insert new bulb into lamp shield and snap in end caps. To replace lamp, lift bulb up into top plunger socket, then set into bottom socket. ***Do not install lamps without lamp shield.***

57. Lamp Socket Replacement

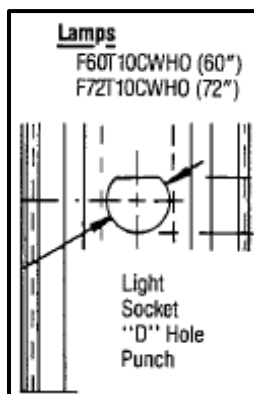

1. To replace sockets, remove lamp, then pull top socket down and pull out of "D" hole. To replace bottom socket, pull socket up and out of "D" hole. Extra lead wire is left in the mullion for easy replacement.
2. Pull sockets out, then cut lead wires.
3. Reverse instructions to replace.
4. To re-install sockets, insert top front metal tab into "D" hole and snap socket up. For bottom socket, insert metal tab into "D" hole and snap socket down to install.
5. Replace lamps.
6. **For safety and efficiency, lamps should never be installed without shields.**

58. Recessed Lamp Replacement

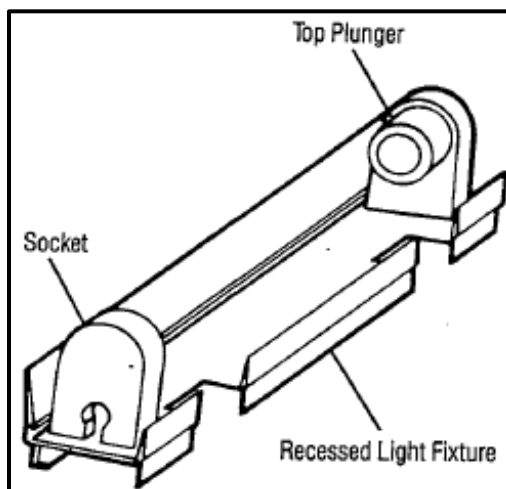

1. Remove light guard per previous instructions.
2. Lift bulb up into top plunger socket and pull bulb out and down at bottom to remove.
3. To replace bulb, insert bulb into top light socket and set into bottom socket.
4. Re-install light guard and clips.

59. “Boost & Buck” Transformer Wiring Diagram

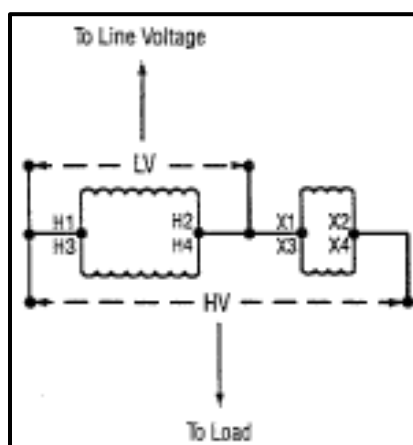

1. Recommended wiring for 110/120 volt applications.
2. Transformer, wired as follows, will increase the 115 volt line voltage by 10% and the applied heat by 20%.
3. Hot to H1-H3.
4. Neutral to H2-X1-X3.
5. Load for heaters X2-X4.
6. Transformer is rated for an 18-Amp load.

Model 100F/100NT/100PR Door Service & Installation

60. Frame Junction Box Wiring (Standard Production)

1. Remove cover.

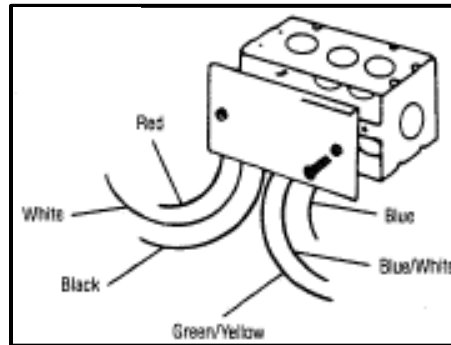

2. Wires are marked as to application.
 - a. 1 - Black for frame heat.
 - b. 1 - Red for door heat.
 - c. 1 - White, common for Black and Red.
 - d. 1 - Blue for lights.
 - e. 1 - Blue/White common for lights.
 - f. 1 - Green/Yellow for ground.

61. Model 100PR Light Fixture Placement

1. Pre-wired lighting uses only 1-light ballasts.
2. Non pre-wired lighting uses 1- or 2-light ballasts

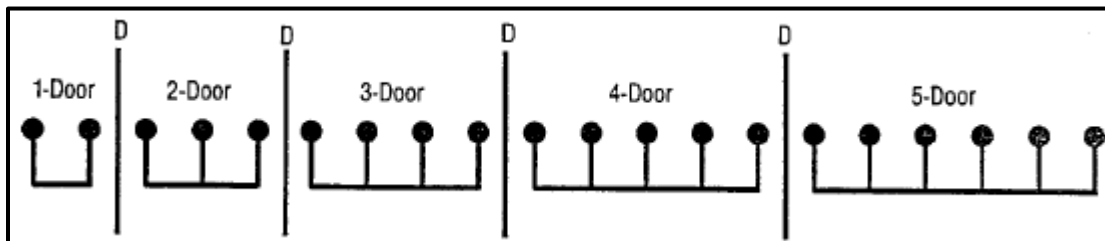

Frame Breakdown – Each Frame with Full Flange

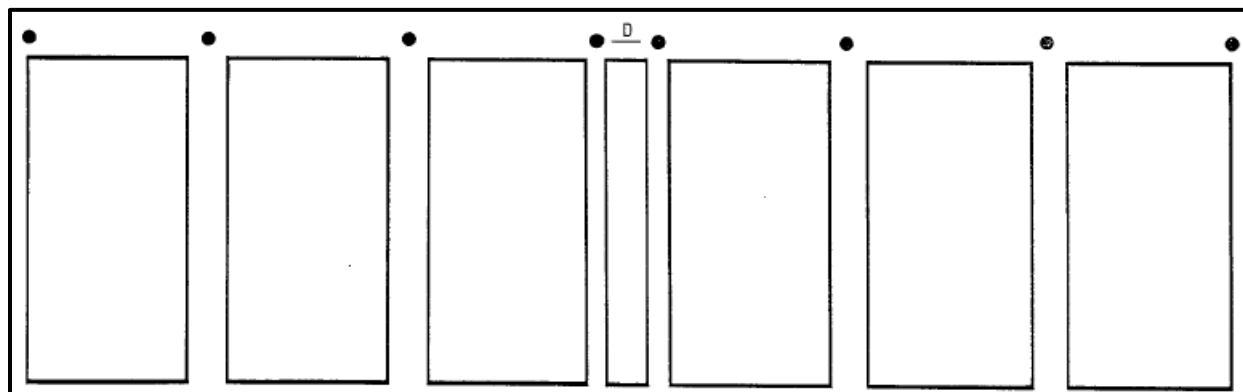

6-Door Lineup of (2 Sets of 3) Model 100PR with Full Flange

62. Model100-Low Temp 120V Ballast & Lamp Wiring Diagram for 1-Light Systems

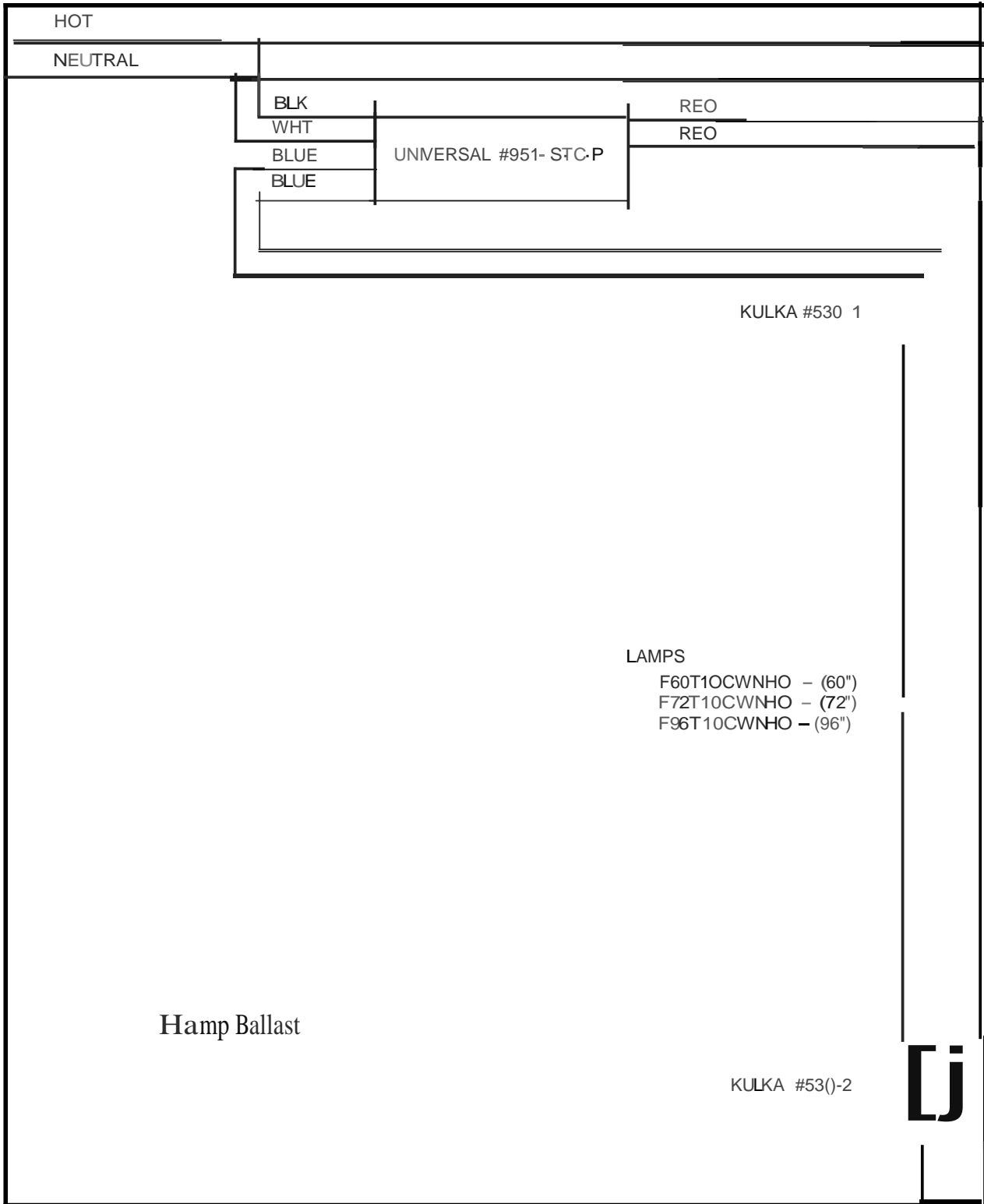

Model100F/100NT/100PR Door Service & Installation

63. Model100- Low Temp 120V Ballast & Lamp Wiring Diagram for 2-Light Systems

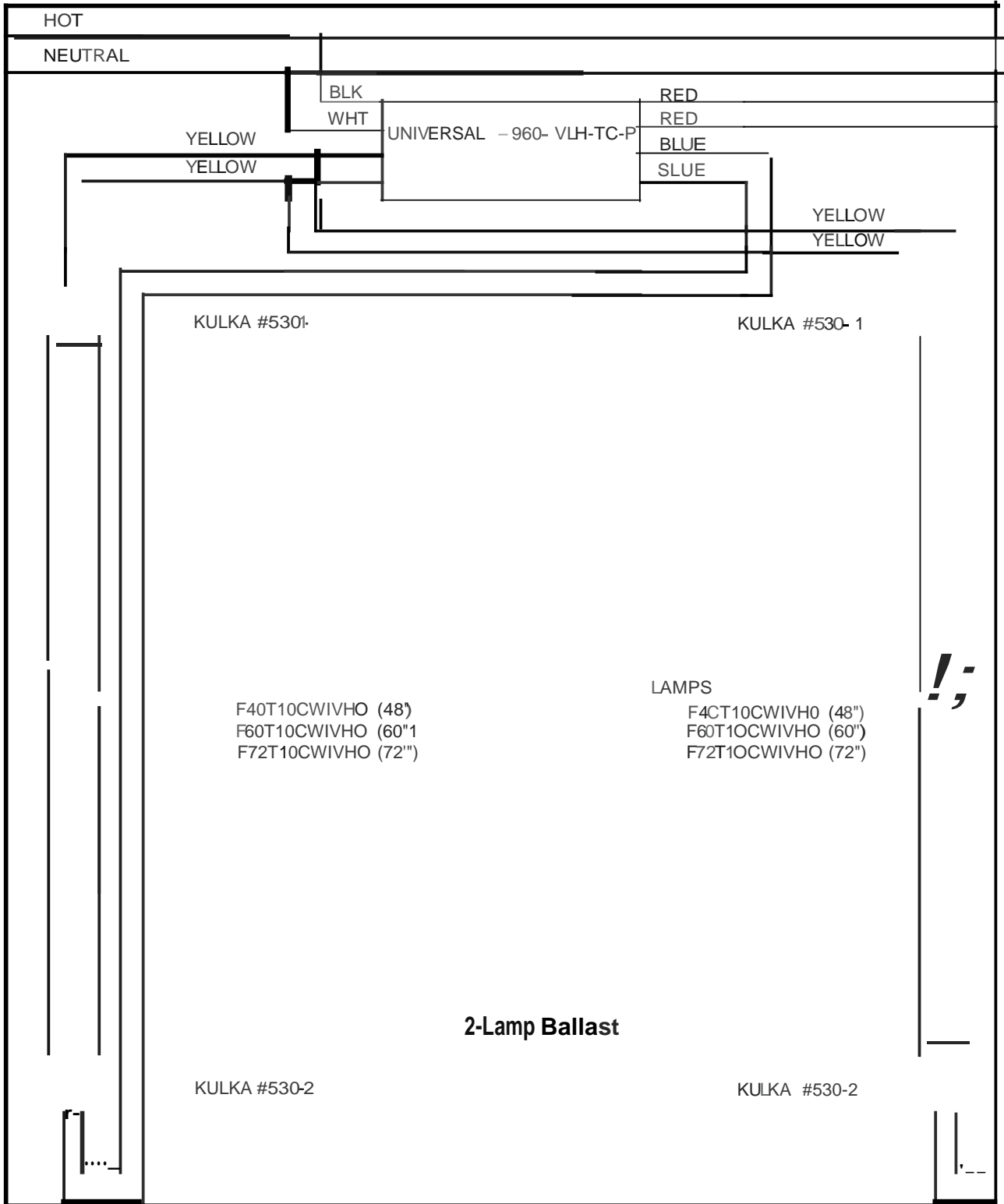

Model 100F/100NT/100PR Door Service & Installation

64. Fan Delay Switch Retrofit & Replacement

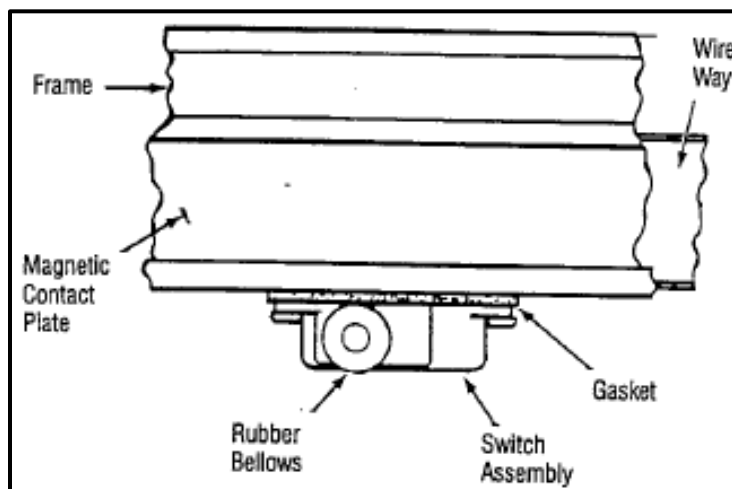

1. Turn off power to fan delay switch.
2. Remove switch assembly mounting screws.
3. Identify switch leads and disconnect switch.
4. Remove any permagum residue on raceway.
5. Re-connect new switch and connectors.
6. Turn on power and test switch.
7. Turn power off and remount switch assembly.

65. Klix-on (Thermo-Disc) Installation Instructions

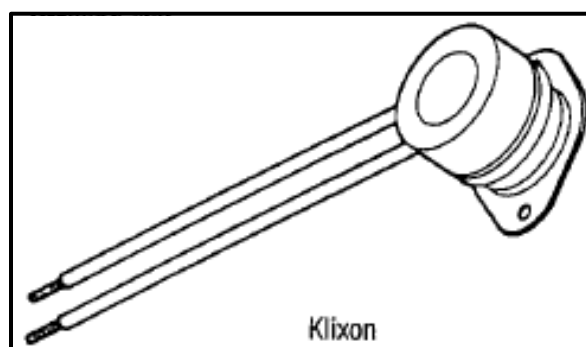

1. The Klix-on (Thermo-Disc) automatically disconnects power to the anti-sweat heaters in frames and doors in the event of a power loss in the case. This will maintain case temperature for a longer period of time.
2. **Wiring Instructions:** Wire in the same manner as a switch. One lead goes to line lead (Hot); the other, to the load side (anti-sweat heaters).
3. **Location:** The recommended location for this device is in the return air flue.

Model 100F/100NT/100PR Door Service & Installation

66. Dew Point Chart

NORMAL TEMPERATURE APPLICATIONS

GLASS TYPE	ROOM TEMP (F)	CASE TEMPERATURE (F)				
		40	35	30	25	20
TWO PANE NHG*	70	70	66	61	58	53
	75	67	62	59	55	52
	80	63	60	57	53	50
	85	60	58	53	50	49
	90	58	55	52	49	47
THREE PANE NHG*	70	74	71	68	65	62
	75	72	68	66	63	60
	80	68	66	63	60	58
	85	66	64	61	58	56
	90	65	62	59	57	54
TWO PANE REFLECTIVE NHG*	70	76	75	70	67	63
	75	75	70	69	66	62
	80	70	68	66	62	59
	85	68	66	63	60	58
	90	67	64	60	58	56
CP2NT HEATED GLASS	70	98	92	90	84	80
	75	95	90	86	84	77
	80	90	85	81	76	73
	85	86	80	78	72	69
	90	82	78	74	70	66
*NHG = Non Heated Glass		% REL HUMIDITY @ WHICH CONDENSATION FORMS ON GLASS				

LOW TEMPERATURE APPLICATIONS

GLASS TYPE	ROOM TEMP (F)	CASE TEMPERATURE (F)					
		+5	0	-5	-10	-15	-20
CP3RLT HEATED REFLECTIVE GLASS	90	88	83	81	79	76	73
	85	81	80	78	76	72	70
	80	80	78	75	72	70	69
	79	78	77	73	71	68	68
	78	75	73	71	69	67	65
		% REL HUMIDITY @ WHICH CONDENSATION FORMS ON GLASS					

Calculations make no allowance for air leaks or unusual air flow patterns within cases and are intended to be used as guidelines only.

Model 100F/100NT/100PR Door Service & Installation

67. Electrical Information for Model 100PR Low Temp Doors, Frames & Light Fixtures Amperages @ 120 Volts

NUMBER OF DOORS:	1	2	3	4	5	6	7	8	9	10
STYLE: Low temp doors with heaters, Clear 3-Pane Heated Reflective Glass (5.75 W/SQ. FT.)										
APPLICATION: Case Temperature -10°F, Humidity 68%, In-Store @ 75°F ambient.										
24 x 36	1.42	2.44	3.65	4.80	5.99	7.30	8.45	9.60	10.95	11.98
24 x 67	2.08	3.77	5.58	7.52	9.22	11.16	13.10	15.04	16.74	18.44
24 x 73	2.18	4.03	5.98	7.87	9.78	11.96	13.85	15.74	17.94	19.56
26 x 75	2.24	4.29	6.33	8.36	10.52	12.66	14.69	16.72	18.88	21.04
26 x 36	1.55	2.89	4.25	5.68	7.14	8.50	9.93	11.36	12.75	14.28
30 x 67	2.37	4.40	6.57	8.59	10.72	13.14	15.16	17.18	19.71	21.44
30 x 73	2.50	4.68	6.85	9.10	11.34	13.70	15.95	18.20	20.55	22.16
30 x 75	2.59	4.91	7.32	9.66	12.08	14.64	16.98	19.32	21.74	24.16

- NOTES:**
- All amperages are design amperages subject to the following tolerances: units with rail heaters and heated glass +/- 8%.
 - Although the amperages are calculated at 120 volts, all doors are designed to operate without sweating when used within the application parameters with a voltage range of +/- 10%.
 - When calculating lamp amperage, add 1 lamp to the number of doors in the line-up and multiply that number by the appropriate amps per light value.
 - Design parameters do not make allowances for factors such as air leaks or unusual air flow patterns within cases; therefore, some sweating may occur when upper limits of temperature or humidity are encountered.

	11	12	13	14	15	16	17	18	19	20	AMPS PER LIGHT
24 x 36	13.25	14.40	15.59	16.84	17.97	19.20	20.41	21.90	22.85	23.96	NA
24 x 67	20.62	22.56	24.26	26.33	27.66	30.08	31.43	33.48	35.66	36.88	0.85
24 x 73	21.72	23.61	25.52	27.64	29.34	31.48	33.37	35.88	37.46	39.12	0.85
26 x 75	23.05	25.08	27.37	29.40	31.56	33.44	35.60	37.89	39.92	42.08	0.85
26 x 36	15.61	17.04	18.50	19.93	21.42	22.72	24.31	25.50	26.97	28.56	N/A
30 x 67	23.75	25.77	27.90	30.17	32.16	34.36	36.56	39.42	40.93	42.88	0.85
30 x 73	25.05	27.30	29.54	31.98	34.02	36.40	38.70	41.10	43.25	45.36	0.85
30 x 75	26.64	28.98	31.40	33.82	36.24	38.64	41.06	43.56	45.90	48.32	0.85

Model 100F/100NT/100PR Door Service & Installation

**68. Heat Load in BTU/Hr for Glass, Door Rail, Frame Heaters and Lights
(Per Door, with Doors Closed @ 75°F Store Ambient)**

MODEL 100PR LOW TEMPERATURE					
(CLEAR 3-PANE HEATED REFLECTIVE GLASS – CASE TEMP -10°F)					
DOOR SIZE	1 DOOR	2 DOOR	3 DOOR	4 DOOR	5 DOOR
24 x 36	507	895	1343	1790	2238
24 x 67	787	1459	2189	2919	3648
24 x 75	858	1658	2487	3315	4144
30 x 36	561	1079	1618	2158	2697
30 x 67	920	1739	2609	3479	4348
30 x 75	1016	1951	2926	3901	4877

NOTE: Add 10-20% to above values depending on door opening frequency. Add 300 BTU/hr for each lamp used.

MODEL 100PR NORMAL TEMPERATURE					
(2-PANE NON-HEATED GLASS – CASE TEMP 38°F)					
DOOR SIZE	1 DOOR	2 DOOR	3 DOOR	4 DOOR	5 DOOR
24 x 36	685	1145	1605	2065	2525
24 x 67	838	1452	2065	2679	3292
24 x 75	879	1533	2187	2841	3495
26 x 67	867	1509	2151	2792	3434
26 x 75	906	1586	2267	2948	3628
30 x 36	769	1314	1858	2403	2947
30 x 67	908	1591	2274	2957	3639
30 x 75	948	1672	2395	3119	3842

NOTE: Add 10-20% to above values depending on door opening frequency.

MODEL 100PR NORMAL TEMPERATURE					
(CP2NT HEATED GLASS – CASE TEMP 31°F)					
DOOR SIZE	1 DOOR	2 DOOR	3 DOOR	4 DOOR	5 DOOR
24 x 36	745	1265	1785	2304	2824
24 x 67	945	1666	2386	3107	3827
24 x 75	999	1772	2546	3319	4093
26 x 67	976	1728	2479	3230	3981
26 x 75	1025	1824	2624	3424	4224
30 x 36	844	1463	2082	2701	3319
30 x 67	1022	1818	2615	3411	4208
30 x 75	1084	1943	2802	3661	4520

Model 100F/100NT/100PR Door Service & Installation

69. Electrical Information for Model 100PR Normal Temp Doors, Frames & Light Fixtures Amperages @ 120 Volts

NUMBER OF DOORS:	1	2	3	4	5	6	7	8	9	10
STYLE: Normal temp doors with heaters, 2-Pane Non-Heated Glass										
APPLICATION: Case Temperature 38°F, Humidity 65% or less, @ 75°F ambient.										
24 x 36	0.70	1.24	1.74	2.31	2.84	3.48	4.05	4.62	5.15	5.68
24 x 67	1.10	1.89	2.75	3.59	4.39	5.50	6.34	7.18	7.98	8.78
24 x 73	1.17	2.07	2.95	3.92	4.71	5.90	6.87	7.84	8.63	9.42
26 x 75	1.10	1.98	2.82	3.80	4.54	5.64	6.62	7.60	8.34	9.08
26 x 36	1.22	2.14	3.04	3.97	4.96	6.08	7.01	7.94	8.93	9.92
30 x 67	0.79	1.41	2.00	3.66	4.62	4.00	5.66	7.32	8.28	9.24
30 x 73	1.19	2.05	2.99	3.87	4.82	5.98	6.86	7.74	8.69	9.64
30 x 75	1.24	2.20	3.22	4.11	5.08	6.44	7.33	8.22	9.19	10.16

- NOTES:**
1. All amperages are design amperages subject to the following tolerances: non-heated glass +/-5%, heated glass +/- 8%.
 2. Although the amperages are calculated at 120 volts, all doors are designed to operate without sweating when used within the application parameters with a voltage range of +/- 10%.
 3. When calculating lamp amperage, add 1 lamp to the number of doors in the line-up and multiply that number by the appropriate amps per light value.
 4. Design parameters do not make allowances for factors such as air leaks or unusual air flow patterns within cases; therefore, some sweating may occur when upper limits of temperature or humidity are encountered.

	11	12	13	14	15	16	17	18	19	20	AMPS PER LIGHT
24 x 36	6.36	6.93	7.46	7.99	8.52	9.24	9.77	10.30	10.83	11.36	0.46
24 x 67	9.93	10.77	11.57	12.37	13.17	14.36	15.16	15.96	16.76	17.56	0.55
24 x 73	10.79	11.76	12.55	13.34	14.13	15.68	16.47	17.26	18.05	18.84	0.55
26 x 75	10.42	11.40	12.14	12.88	13.62	15.20	15.94	16.68	17.42	18.16	0.55
26 x 36	10.98	11.91	12.90	13.89	14.88	15.88	16.87	17.86	18.85	19.84	0.55
30 x 67	9.32	10.98	11.94	12.90	13.86	14.64	15.60	16.56	17.52	18.48	0.46
30 x 73	10.73	11.61	12.56	13.51	14.46	15.48	16.43	17.38	18.33	19.28	0.55
30 x 75	11.44	12.33	13.30	14.27	15.24	16.44	17.41	18.38	19.35	20.32	0.55

Model 100F/100NT/100PR Door Service & Installation

70. Electrical Information for Model 100PR Normal Temp Doors, Frames & Light Fixtures Amperages @ 120 Volts

NUMBER OF DOORS:	1	2	3	4	5	6	7	8	9	10
STYLE: Normal temp doors with heaters, CP2NT Heated Glass (5.75 W/SQ. FT.)										
APPLICATION: Case Temperature 31°F, Humidity 80% or less, @ 75°F ambient.										
24 x 36	1.00	1.83	2.66	3.47	4.32	5.32	6.13	6.94	7.79	8.64
24 x 67	1.64	3.07	4.44	5.89	7.16	8.88	10.33	11.78	13.05	14.32
24 x 75	1.79	3.34	4.80	6.26	7.85	9.60	11.06	12.52	14.11	15.70
26 x 67	1.79	3.27	4.72	6.19	7.74	9.44	10.91	12.38	13.93	15.48
26 x 75	1.93	3.55	5.19	6.75	8.39	10.38	11.94	13.50	15.14	16.78
30 x 36	1.18	2.24	3.23	6.18	7.79	6.46	9.41	12.36	13.97	15.58
30 x 67	1.89	3.44	5.07	6.55	8.12	10.14	11.62	13.10	14.67	16.24
30 x 75	2.05	3.80	5.56	7.26	9.00	11.12	12.82	14.52	16.26	18.00

- NOTES:**
1. All amperages are design amperages subject to the following tolerances: non-heated glass +/-5%, heated glass +/- 8%.
 2. Although the amperages are calculated at 120 volts, all doors are designed to operate without sweating when used within the application parameters with a voltage range of +/- 10%.
 3. When calculating lamp amperage, add 1 lamp to the number of doors in the line-up and multiply that number by the appropriate amps per light value.
 4. Design parameters do not make allowances for factors such as air leaks or unusual air flow patterns within cases; therefore, some sweating may occur when upper limits of temperature or humidity are encountered.

	11	12	13	14	15	16	17	18	19	20	AMPS PER LIGHT
24 x 36	9.60	10.41	11.26	12.11	12.96	13.88	14.73	15.58	16.43	17.28	0.46
24 x 67	16.22	17.67	18.94	20.21	21.48	23.56	24.83	26.10	27.37	28.64	0.55
24 x 75	17.32	18.78	20.37	21.96	23.55	25.04	26.63	28.22	29.81	31.40	0.55
26 x 67	17.10	18.57	20.12	21.67	23.22	24.76	26.31	27.86	29.41	30.96	0.55
26 x 75	18.69	20.25	21.89	23.53	25.17	27.00	28.64	30.28	31.92	33.56	0.55
30 x 36	15.59	18.54	20.15	21.76	23.37	24.72	26.33	27.94	29.55	31.16	0.46
30 x 67	18.17	19.65	21.22	22.79	24.36	26.20	27.77	29.34	30.91	32.48	0.55
30 x 75	20.08	21.78	23.52	25.26	27.00	29.04	30.78	32.52	34.26	36.00	0.55

Model 100F/100NT/100PR Door Service & Installation

71. Troubleshooting

1. **Electrical:** Low voltage supply (less than 108V on 120V systems) results in significantly lower wattage. Lower wattage will decrease the efficiency of heaters and lamps.
 - A. Glass Condensation:
 1. No Power? Check:
 - a. Power supply
 - b. Relative humidity in room area
 - c. Hinge pin wiring
 - d. Case temperature
 - e. Hinge pin plugged into door female plug
 - f. Incorrect wiring
 - g. Faulty Energy Management System (Sensor)
 2. Low Voltage? Check voltage at main power source.
 - a. Voltage at main – low voltage
 - b. Energy Management System (Sensor)
 - B. Door and Frame Rail Condensation:
 1. No Power? Check:
 - a. Power supply
 - b. Relative humidity in room area
 - c. Hinge pin wiring
 - d. Case temperature
 - e. Hinge pin installed in female plug in door
 - f. Velocity fans on back of frame
 - g. Energy Management System (Sensor)
 2. Low Voltage? Check :
 - a. Supply Voltage – Low Voltage
 - b. Energy Management System (Sensor)
2. **Mechanical:**
 - A. Door Not Sealing? Check:
 1. Magnetic gasket (Replace if necessary)
 2. Torquemaster adjustment
 3. Hold-Open
 4. Defective frame plastic
 5. Frame or door out of square
 - B. Door Will Not Close?
 1. See instructions 2a, 1 through 5
 - C. Door Saw Toothed?
 1. Door or frame out of square? (Square to 1/16" of net opening)
 2. Adjust Torquemaster
 3. Worn hinge pin hole
 4. Case not level
 5. Frame not shimmed properly

Model 100F/100NT/100PR Door Service & Installation

3. Ballast/Lamps:

- A. Lamps will not start?
 - 1. Ballast failure
 - 2. Incorrect ballast
 - 3. Incorrect wiring
 - 4. Incorrect bulb
 - 5. Poor contact between bulb and socket
 - 6. Case too cold. (Lamps will usually light, but they will be very dim)
 - 7. Incorrect socket wiring
 - 8. No ground
- B. Lamp Flickering?
 - 1. Incorrect ballast
 - 2. Defective bulb
 - 3. Incorrect voltage
 - 4. Bulbs without shields
- C. Slow-Starting Bulbs?
 - 1. Improper wiring
 - 2. Poor lamp and socket connections
 - 3. Voltage too low
 - 4. Defective bulbs
 - 5. Incorrect ballast
 - 6. Case too cold
- D. Short Lamp Life?
 - 1. Incorrect wiring of lamp or ballast
 - 2. Incorrect socket connection
 - 3. Incorrect bulbs or ballast
- E. Blinking Lamps?
 - 1. Voltage too high
 - 2. Wrong bulbs or ballast
 - 3. Incorrect socket wiring
 - 4. Incorrect number of lamps for ballast
- F. Ballast (Humm-Noise)?
 - 1. Defective ballast
 - 2. Loose ballast can or cover
 - 3. Ballast mounted incorrectly

Model 100F/100NT/100PR Door Service & Installation

72. Safety Precautions

1. Always turn off power to case, doors and frames before starting work on equipment.
2. Always use a qualified electrician for electrical work.
3. Always wear safety glasses when working on equipment.

73. Tips

1. **Never splice door or frame heater wires.** Complete replacement recommended.
2. When installing gasket and plastics, use a liquid soap.
3. Keep doors and frames clean.
4. For binding gasket or plastic parts, use a food grade silicone.
5. Always replace lamp shields when lamps are replaced.
6. Preventive maintenance is the key to door and frame longevity.



COMPANY POLICIES, TERMS OF SALE, AND WARRANTY

The following terms and conditions shall apply to all transactions and agreements between Anthony, Inc. ("Anthony") and the other party to such transaction or agreement ("Buyer") with respect to the purchase of any goods from Anthony and/or the extension of credit by Anthony to Buyer for such purchase.

1. PRICE. Prices shown on the face of the sales invoice are F.O.B. the place of shipment as designated by Anthony, packaged for shipment and subject to change without notice.

2. TERMS OF CREDIT. All credit terms are net 30 days from date of invoice. Any deductions from the net invoice amount must be approved by a representative of Anthony authorized to make such changes. If credit is extended to Buyer, Anthony reserves the right to revoke such credit if Buyer fails to make timely payment for any goods delivered. Anthony reserves the right to require payment or other assurances which it deems necessary prior to the shipment of any goods, if, in Anthony's opinion, exercised in Anthony's subjective, good faith judgment, the Buyer's financial condition has deteriorated or the risk of non-payment has otherwise increased. Credit is subject to approval upon receipt of completed credit application. Any goods shipped prior to credit approval shall be shipped C.O.D., "Cashiers Check", or pre-payment. A \$25.00 charge will be applied for each returned check. Goods may not be returned for credit unless prior authorization and an authorization number have been granted by Anthony. A 1 ½ % per month charge will be assessed on past due amounts.

3. SHIPMENT OF GOODS / RETURN OF GOODS. Every effort will be made to ship the goods on the scheduled shipment date and to maintain production schedules consistent therewith provided however, Anthony shall not be liable for any claims or consequential damages arising from the failure to meet any scheduled shipping dates. If Buyer refuses shipment of any standard catalog products under an acknowledged order and those products are consistent with that order and are not delivered damaged or defective, then Buyer will be responsible for (i) return shipment of the products to Anthony in original shipping containers; (ii) return freight to Anthony prepaid by Buyer; and (iii) a restocking charge to be determined by Anthony of not less than twenty-five percent (25%) of the sales price. Buyer assumes the risk of any return shipment damage or loss, the cost of which will be assessed by Anthony and added to the restocking charge. No custom products or custom sizes of catalog items may be returned to Anthony for credit unless those products are not consistent with an acknowledged order or they are defective. If they are defective, Anthony reserves the right to cure the defect at the ship-to location. Costs for special packaging and/or handling requested by Buyer will be billed to Buyer. Shipping terms are specified on the face of Anthony's quotation and/or price list, as applicable. Unless otherwise specified by Buyer in writing, Anthony shall select the method of shipment and direct shipment of materials to the specified delivery address of Buyer. In the event of any general freight increase or any governmental ruling or regulation that results in increased freight costs, Anthony may, without any advance notice, invoice Buyer for such additional costs. Acceptance and rejections of glass sheets, assembled sealed glass units, and finished doors shall be in accordance with the defect criteria set forth in Industry Specification ASTM C1036-06 Standards, level Q3.

4. RISK OF LOSS. Subject to security interests retained by Anthony until payment for the goods is received in full, the title to such goods and risk of loss or damages thereto pass to Buyer upon completion of loading of goods on carrier at Anthony's factory. Buyer will unload shipments promptly and Buyer will be liable for any additional charges such as demurrage, storage, and labor incurred by its failure to do so. Any claims by Buyer for damages to the goods incurred during shipping shall be made to the carrier.

5. WARRANTIES. The products which Anthony manufacture and offer for sale are warranted to: (i) be free from defects in materials and workmanship; and (ii) perform in accordance with applicable refrigeration standards as of the date of manufacture for a period of 12 months from the date and place of shipment, provided that the installation and maintenance of such products have been performed strictly in accordance with Anthony's designated specifications (the "Warranty"). Anthony shall provide all necessary parts and labor at its cost to fulfill said Warranty. All parts will be shipped standard ground freight. The extent of Anthony's liability under the Warranty is limited to the repair or replacement, at Anthony's option, of any non-conforming products without charge, at Anthony's Sylmar manufacturing plant. Additionally, for a period of 10 years from the shipment date, Anthony will replace sealed glass units that are part of an original Anthony-manufactured door if the seal breaks and internal condensation results. Anthony-manufactured LED lighting have a five (5) year component warranty and twelve (12) month labor warranty. The anti-fog coating is only warranted for a period of twelve (12) months from date of shipment. Anthony reserves the right to change its warranty provisions at its sole discretion at any time with or without prior notification of such change.

No Warranty for Non-Standard Products.

A "Non-Standard Product" is any product that is different in any manner from any Anthony product that has been previously designed and manufactured by Anthony in accordance with its standard specifications. A Non-Standard Product also includes any standard Anthony product that has been specially designed or modified to meet a particular Buyer specification, or that contains any additional or substituted product, part, accessory, equipment, fixture, component or material, or that has been assembled, manufactured, produced, or installed by any method or process, which is different from Anthony's standard specifications for such product. Anthony expressly disclaims and make no warranties, express or implied, as to the condition, design, utility, quality, adequacy, or capacity with respect to any standard or Non-Standard Product, including, without limitation, any warranty of merchantability or fitness of such product for a particular purpose or intended use, whether or not such product has been designated by Anthony as a Non-Standard Product.

All Non-Standard Products, whether sold separately, or incorporated and/or attached to standard Anthony products, and all services relating to such products, are sold to and accepted by Buyer "as is" and "with all faults". Without limiting any other provision of this purchase order, Anthony shall have no liability to Buyer for any claim, loss, damage, consequential damages or expense associated with any Non-Standard Product and/or its use or operation, or any other equipment or property of Buyer caused by or alleged to be caused by any such product or its use or operation, whether directly, indirectly, incidentally or consequentially, or by any inadequacy thereof or deficiency or defect therein.

The foregoing exclusion of warranty cannot be modified or waived except as expressly set forth in a writing signed by an officer of Anthony authorized to make such modification or waiver.

THE ABOVE WARRANTY IS GIVEN IN LIEU OF ALL OTHER WARRANTIES, EXPRESSED OR IMPLIED, INCLUDING ANY IMPLIED WARRANTIES OF MERCHANTABILITY OR FITNESS FOR A PARTICULAR PURPOSE. ANTHONY SHALL NOT BE RESPONSIBLE FOR INCIDENTAL OR CONSEQUENTIAL DAMAGES INCLUDING BUT NOT LIMITED TO INJURY TO PERSONS OR PROPERTY.

6. ACCEPTANCE OF PRODUCTS BY BUYER/CLAIMS: Upon delivery, shipments must be inspected for damage, loss or shortage prior to acceptance from the carrier. If damage or shortage exists with respect to any shipment and it is not concealed, Buyer shall secure a notation of such damage or shortage from the delivering agent on the freight bill or delivery receipt. If damage is concealed, Buyer must notify Anthony within five (5) days of its delivery and hold the merchandise for its inspection. Any claims for visible loss or damage should be filed by Buyer with Anthony in writing immediately upon receipt of the materials. All claims of Buyer that materials delivered do not conform to the accepted order shall be handled as claims for breach of warranty and Buyer shall be limited to those remedies available for breach of warranty.

7. CLAIMS BY BUYER. Anthony shall thereupon be afforded a reasonable opportunity to inspect the goods. All claims not made in the time period and manner specified above shall be deemed waived. All actions, claims or defenses by Buyer shall be deemed waived unless commenced or asserted within six (6) months of receipt of the goods. No claims for visible, external damage or shortage will be allowed unless they are accompanied by an inspection report or signed delivery receipt noting such loss or damage signed by a representative of the carrier and forwarded to the Anthony Vice President, Marketing & Sales within 30 days of the invoice date.

8. CANCELLATION. Orders may not be canceled after receipt by Anthony unless Anthony consents in writing to such cancellation. Cancellation will be granted only on terms indemnifying Anthony against any loss resulting from such action. At minimum, Buyer will be liable for all cost incurred on the order through the cancellation date.

9. CHANGES BY ANTHONY. Anthony reserves the right to change design, colors and specifications of any goods without notice to Buyer.

10. DEFAULT. If Buyer defaults or fails to pay on the purchase of any goods or if a petition in bankruptcy is filed by or against Buyer, Anthony, in addition to other remedies, may repossess any goods which were previously delivered and for which payment has not been received, and may refuse to make further shipment of goods. Buyer agrees to pay Anthony's attorneys' fees, costs and expenses incurred as a result of Buyer's default or failure to pay, including but not limited to any collection or repossession expenses.

11. ENTIRE AGREEMENT AND AMENDMENT. The terms specified herein constitute the entire agreement between Anthony and Buyer with respect to the sale and purchase of the goods and any extension of credit. If Anthony and Buyer agree to amend or modify any terms and conditions specified herein, such amendment or modification must be expressly stated on the face of the sales invoice or by a written agreement duly executed by an officer of Anthony and the Buyer. The terms specified herein shall control in the event of any variance between these terms and any terms contained in Buyer's purchase orders.

12. GOVERNING LAW. This purchase order, any agreements between Anthony and Buyer and all other claims that arise between the parties, whether sounding in contract or tort, shall be governed by, construed and enforced in accordance with the laws of the State of California. By entering into this purchase order and any other agreement with Anthony, Buyer consents to the jurisdiction of the courts of the State of California to determine all claims between the parties, regardless of whether said claims are contract claims, tort claims, patent claims, trademark claims or copyright claims. Venue of any lawsuit (State or Federal) against Anthony must be filed in Los Angeles County, California. Service of process on Buyer may be made by registered mail addressed to the Buyer.

13. SEVERABILITY. If any provision of the terms and conditions specified herein shall be deemed invalid or unenforceable, the remaining terms and conditions shall be construed as though such provision does not appear herein and shall be otherwise fully enforceable.

14. HEADINGS. The section headings contained herein have been inserted for convenient reference and shall not be considered in any questions of interpretation or construction of any agreements between Anthony and Buyer.

Anthony products are covered by one or more of the following United States Patents: RE035392, 5301092, 5720540, 5879070, 5895111, 5910083, 5902034, 5959816, 6102277, 6298615, 6302036, 6302557, 6389993, 6343405, 5116274, 5244273, 5255473, 5333353, 5471372, 5645330, 6632100, 6637093, 6638088, 6773130, 6641419, 6490983, 6606832, 6606833, 5884361, D600529, 7603882, 7273299, 7674019, D404935, D395968, D612517, 5622414, 7731395, 8250873 B2.

Anthony products are covered by one or more of the following Foreign Patents: Canada: 2233401, Mexico: 185899, 186644, 202491, 238593, 2273131, 236690. Other United States and Foreign Patents Pending.

99-18396-W001_E (01/02/2014)